

SOLLEVATORI OLEOPNEUMATICI

AIR HYDRAULIC JACKS

312

510



Sollevatori Oleopneumatici con rientro automatico dei pistoni. Studiati appositamente per il sollevamento degli autobus e di quei mezzi i cui assali risultano essere molto bassi.

Air-hydraulic jacks with pistons moving back automatically. Specifically designed for lifting buses and all vehicles with low profile axles.

	YAK 312	YAK 510
Portata Capacity	60/30/15 t 66/33/17 ton	44/32/22/14/8 t 49/35/24/15/9 ton
Peso netto Net weight	44 kg 97 lb	63 kg 139 lb
Pressione di alimentazione Working air pressure	8-10 bar 116-145 psi	8-10 bar 116-145 psi
Consumo d'aria Air waste	600 nl/min	600 nl/min

ACCESSORI INCLUSI INCLUDED ACCESSORIES

-  1x A02354
-  1x A02406
-  1x A02410
-  2x A04676

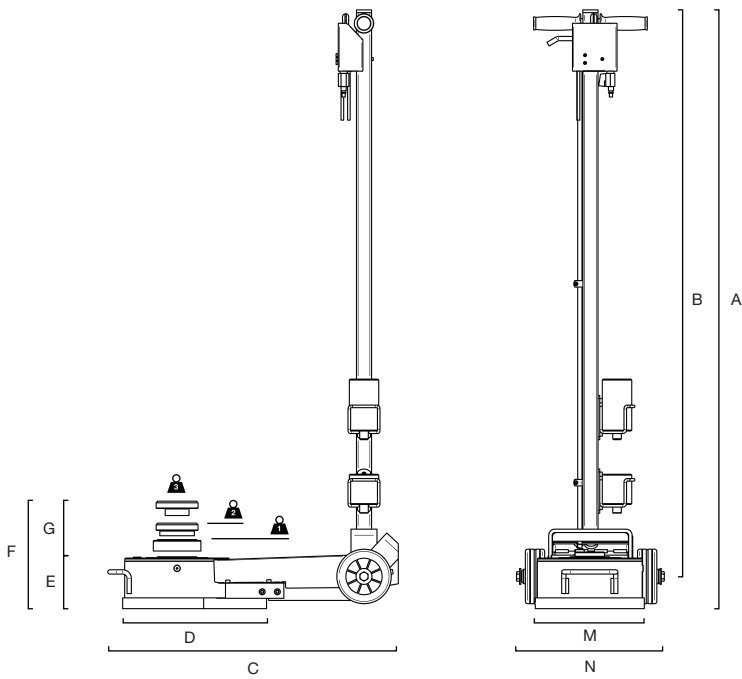

	YAK 312	YAK 510
A	1390 mm 54.72 in	1385 mm 54.53 in
B	1310 mm 51.57 in	1310 mm 51.57 in
C	660 mm 25.98 in	1000 mm 39.37 in
D	335 mm 13.19 in	320 mm 12.60 in
E	120 mm 4.72 in	100 mm 3.94 in
F	252 mm 9.92 in	252.5 mm 9.94 in
G	132 mm 5.20 in	152.5 mm 6 in
H		500 mm 19.69 in
M	252 mm 9.92 in	240 mm 9.45 in
N	345 mm 13.58 in	355 mm 13.98 in

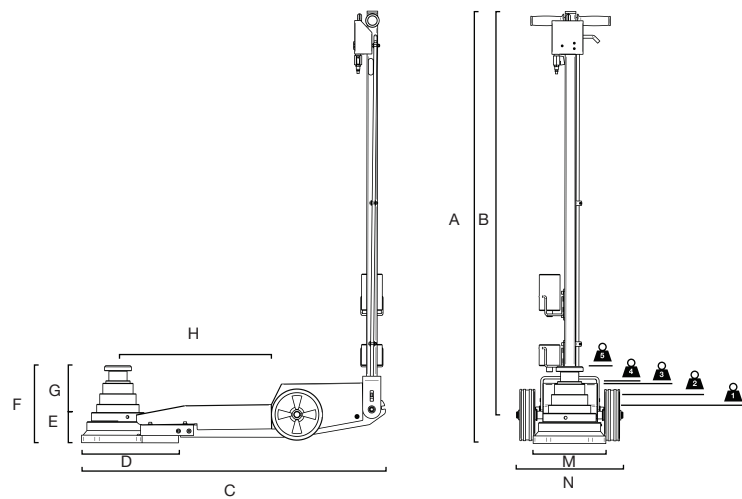

	60 t 66 ton	44 t 49 ton
	30 t 33 ton	32 t 35 ton
	15 t 17 ton	22 t 24 ton
		14 t 15 ton
		8 t 9 ton



YAK312
YAK510

