



Air hydraulic jack engineered and manufactured to offer a solution that is safe and easy to use.

Main features:

- light, compact, easy to handle
- folding handle
- standard remote control
- pneumatic tyres for any surface

*Sollevatore oleopneumatico progettato e costruito per offrire una soluzione sicura e di facile utilizzo.*

*Caratteristiche principali:*

- *estrema leggerezza, compattezza e maneggevolezza*
- *manico pieghevole*
- *comando remoto di serie*
- *ruote pneumatiche per qualsiasi superficie*



# M200-90

**SUITABLE FOR  
ADATTO A**

Mine and oil field / Construction site  
Industrial assembly / Agriculture / Railway applications / Military  
*Miniera e giacimento petrolifero / Cantiere  
Assemblaggio industriale / Agricoltura / Applicazioni ferroviarie / Militare*



	Capacity Portata	Net weight Penso netto	Working air press. Press. di alimentazione	Air consumption Consumo d'aria	Max. height Altezza max.	Min. height Altezza min.	Number of pistons Numero sfili	Stroke Corsa
<b>M200-90</b>	200 t 220.4 ton	450 Kg 992 lb	10-12 bar 145-174 psi	600 nl/min	1450 mm 57 in	900 mm 35.4 in	1	550 mm 21.6 in



## Dimensions - Dimensionali

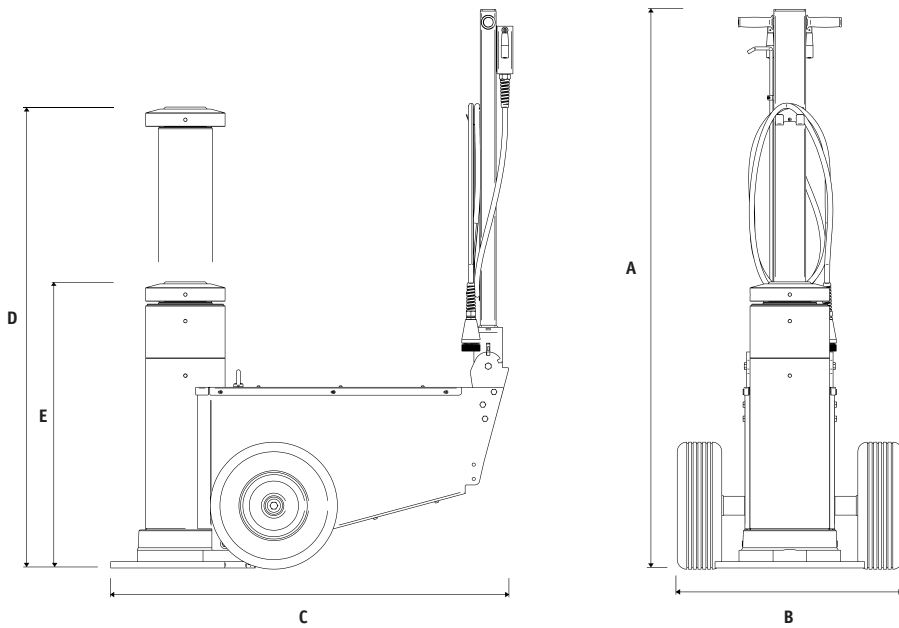

A	1757 mm 69.2 in
B	708 mm 27.8 in
C	1253 mm 49.3 in
D	1450mm 57 in
E	900 mm 35.4 in

## Accessories - Accessori



Code Codice	Description Descrizione
A07326	Safety Blocks Kit Kit Blocchi di Sicurezza
A06051	Extension Holder R Portaprolunghe DX
A06052	Extension Holder L Portaprolunghe SX
A02421	Extension Prolunga A: 200mm B: 55mm C: 55mm
A02422	Extension Prolunga A: 250mm B: 55mm C: 55mm
A02423	Extension Prolunga A: 300mm B: 55mm C: 55mm
A04495	Tilting plate Piatello basculante A: 77mm B: 55mm

### A07326 KIT :

- 1x Safety Lock Holder - *Portablocchi*
- 5x Safety Block - *Blocco di sicurezza* - H100 - 250 mm
- 1x Safety Block - *Blocco di sicurezza* - H50 - 250 mm

