



Air hydraulic jack engineered and manufactured to offer a solution that is safe and easy to use.

Main features:

- light, compact, easy to handle
- folding handle
- standard remote control
- pneumatic tyres for any surface

*Sollevatore oleopneumatico progettato e costruito per offrire una soluzione sicura e di facile utilizzo.*

*Caratteristiche principali:*

- estrema leggerezza, compattezza e maneggevolezza
- manico pieghevole
- comando remoto di serie
- ruote pneumatiche per qualsiasi superficie



# M100-90

**SUITABLE FOR**  
**ADATTO A**

Mine and oil field / Construction site  
Industrial assembly / Agriculture / Railway applications / Military  
*Miniera e giacimento petrolifero / Cantiere*  
*Assemblaggio industriale / Agricoltura / Applicazioni ferroviarie / Militare*



	Capacity Portata	Net weight Penso netto	Working air press. Press. di alimentazione	Air consumption Consumo d'aria	Max. height Altezza max.	Min. height Altezza min.	Number of pistons Numero sfili	Stroke Corsa
<b>M100-90</b>	100 t 110.2 ton	377 Kg 831 lb	10-12 bar 145-174 psi	600 nl/min	1466 mm 57.7 in	900 mm 35.4 in	1	566 mm 22.2 in



## Dimensions - Dimensionali

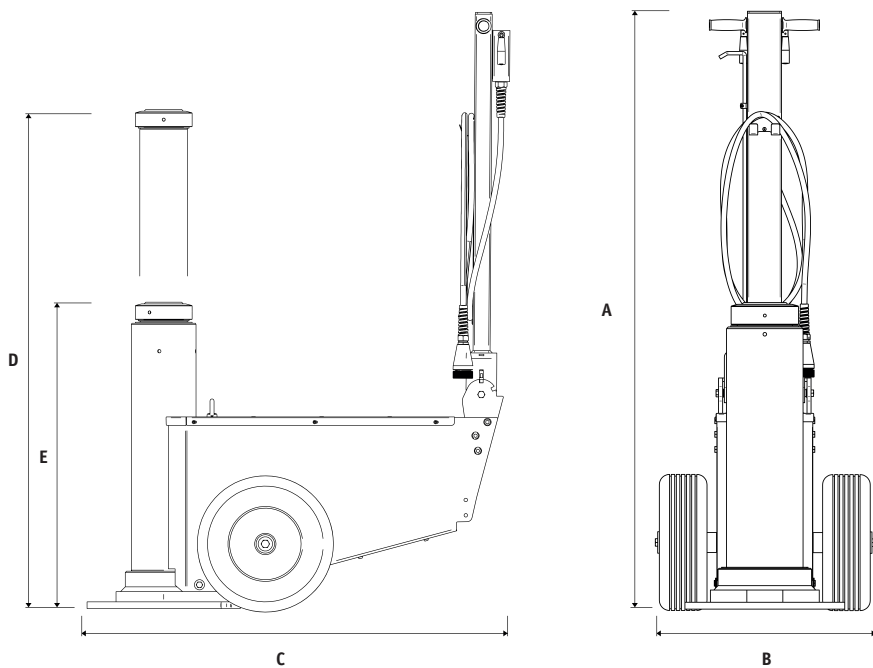

A	1751 mm 68.9 in
B	644 mm 25.3 in
C	1222 mm 48.1 in
D	1466 mm 57.7 in
E	900 mm 35.4 in

## Accessories - Accessori



A07350



A06051



A06052



A02421



A02422



A02423



A04495

Code Codice	Description Descrizione
A07350	Safety Blocks Kit Kit Blocchi di Sicurezza
A06051	Extension Holder R Portaprolunghe DX
A06052	Extension Holder L Portaprolunghe SX
A02421	Extension Prolunga A: 200mm B: 55mm C: 55mm
A02422	Extension Prolunga A: 250mm B: 55mm C: 55mm
A02423	Extension Prolunga A: 300mm B: 55mm C: 55mm
A04495	Tilting plate Piatello basculante A: 77mm B: 55mm

### A07350 KIT:

- 1x Safety Lock Holder - *Portablocchi*
- 4x Safety Block - *Blocco di sicurezza* - H100 - 177mm
- 1x Safety Block - *Blocco di sicurezza* - H50 - 177mm

