



ATLAS



Safe locking air-hydraulic jack.

Main features:

- Mechanical safety lock sealed inside the cylinder unit to protect it from dirt and dust
- Standard remote control for all functions
- "Safe Load" LED indicators
- Standard air filter
- Lightweight, compact, easy to handle and safe to use
- Folding handle
- Pneumatic tyres for any surface

Sollevatore oleopneumatico "safe locking".

Caratteristiche principali:

- *Blocco meccanico di sicurezza sigillato all'interno del cilindro per proteggerlo da sporco e polvere*
- *Comando remoto di serie per lo svolgimento di tutte le funzioni*
- *Indicatori LED dello stato di sicurezza del carico*
- *Filtro aria di serie*
- *Leggero, compatto, maneggevole e sicuro*
- *Manico pieghevole*
- *Ruote pneumatiche per qualsiasi superficie*



M100-72-ATLAS

SUITABLE FOR
ADATTO A

Mine and oil field / Construction site
Industrial assembly / Agriculture / Railway applications / Military
*Miniera e giacimento petrolifero / Cantiere
Assemblaggio industriale / Agricoltura / Applicazioni ferroviarie / Militare*

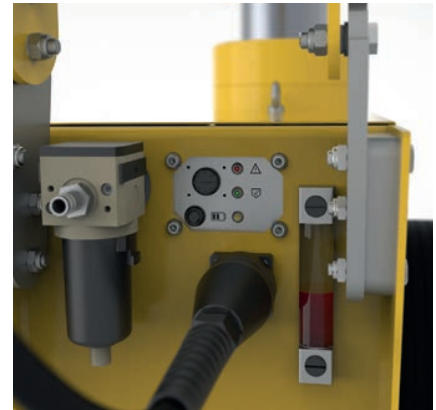

	Capacity Portata	Net weight Penso netto	Working air press. Press. di alimentazione	Air consumption Consumo d'aria	Max. height Altezza max.	Min. height Altezza min.	Number of pistons Numero sfili	Stroke Corsa
M100-72-ATLAS	100 t 110.2 ton	427 Kg 941 lb	10-12 bar 145-174 psi	600 nl/min	1062 mm 46.9 in	722 mm 28.4 in	1	340 mm 13.3 in



Dimensions - Dimensionali

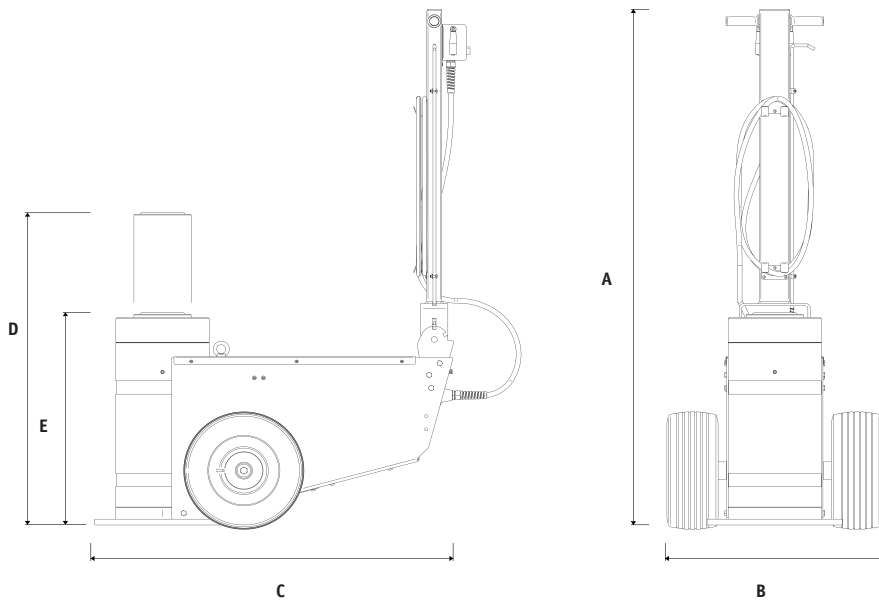

A	1753 mm 69 in
B	720 mm 28.3 in
C	1193 mm 46.9 in
D	1062mm 41.8 in
E	722 mm 28.4 in

Accessories - Accessori



Code Codice	Description Descrizione
A06051	Extension Holder R Portaprolunghe DX
A06052	Extension Holder L Portaprolunghe SX
A02421	Extension Prolunga A: 200mm B: 55mm C: 55mm
A02422	Extension Prolunga A: 250mm B: 55mm C: 55mm
A02423	Extension Prolunga A: 300mm B: 55mm C: 55mm
A04495	Tilting plate Piatello basculante A: 77mm B: 55mm

