



HPM
HIGH - PERFORMANCE - MOTORPUMP



Air hydraulic jack engineered and manufactured to offer a solution that is safe and easy to use.

Main features:

- new High Performance Motor pump (HPM)
- light, compact, easy to handle
- folding handle
- standard remote control
- pneumatic tyres for any surface

Sollevatore oleopneumatico progettato e costruito per offrire una soluzione sicura e di facile utilizzo.

Caratteristiche principali:

- nuova motopompa ad alte prestazioni (HPM)
- estrema leggerezza, compattezza e maneggevolezza
- manico pieghevole
- comando remoto di serie
- ruote pneumatiche per qualsiasi superficie



M100-40

SUITABLE FOR
ADATTO A

Mine and oil field / Construction site
Industrial assembly / Agriculture / Railway applications / Military
Miniera e giacimento petrolifero / Cantiere
Assemblaggio industriale / Agricoltura / Applicazioni ferroviarie / Militare



	Capacity Portata	Net weight Peso netto	Working air press. Press. di alimentazione	Air consumption Consumo d'aria	Max. height Altezza max.	Min. height Altezza min.	Number of pistons Numero sfili	Stroke Corsa
M100-40	100 t 110.2 ton	168 Kg 370 lb	10 - 12 bar 145 - 174 psi	600 nl/min	602 mm 23.7 in	399 mm 15.7 in	1	203 mm 8 in



Dimensions - Dimensionali

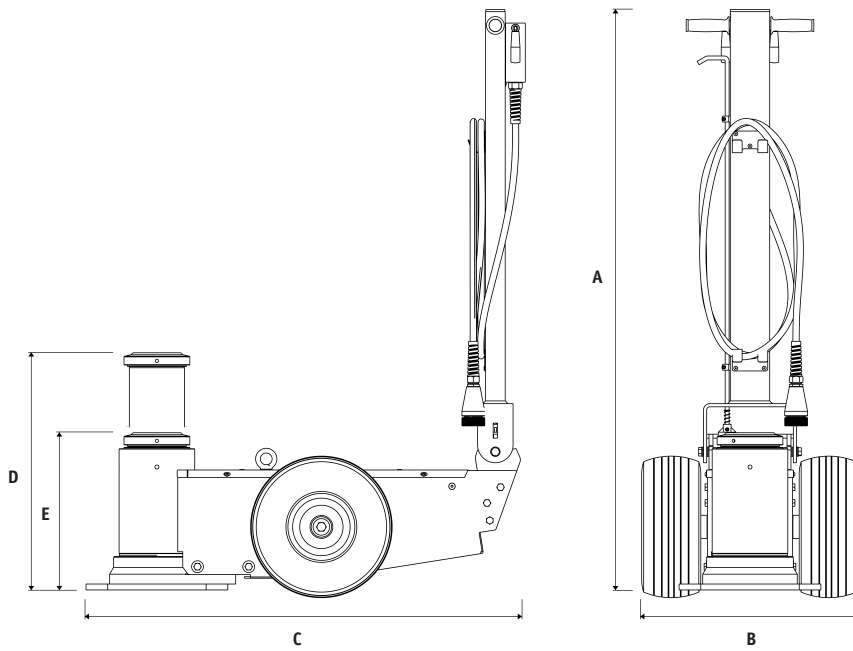

A	1473 mm 57.9 in
B	550 mm 21.6 in
C	1102 mm 43.4 in
D	602 mm 23.7 in
E	399 mm 15.7 in

Accessories - Accessori



Code Codice	Description Descrizione
A05102	Safety Blocks Kit Kit Blocchi di Sicurezza
A06053	Extension Holder R Portaprolunghe DX
A06054	Extension Holder L Portaprolunghe SX
A04405	Extension Prolunga A: 80mm B: 35mm C: 20mm
A02432	Extension Prolunga A: 150mm B: 35 mm C: 20mm
A02434	Extension Prolunga A: 250mm B: 35 mm C: 20mm
A02436	Extension Prolunga A: 300mm B: 35 mm C: 20mm
A04492	Tilting plate Piatello basculante A: 46mm B: 35 mm

A05102 KIT:

- 1x Safety Lock Holder - *Portablocchi*
- 1x Eyebolt Extension - *Prolunga golfare*
- 2x Safety Block - *Blocco di sicurezza* - H100 - 177mm
- 1x Safety Block - *Blocco di sicurezza* - H50 - 177mm

