



SPX Corporation
5885 11th Street
Rockford, IL 61109-3699 USA

Tech. Services: (800) 477-8326
Fax: (800) 765-8326
Order Entry: (800) 541-1418
Fax: (800) 288-7031

Internet Address:
<http://www.powerteam.com>

Form No. 102810

Operating Instructions for:

PR2100J	PR3100J
PR2100J-50-220	PR3100J-50-380
PR2100S	PR3100S

MODEL C
**UNIVERSAL RAILROAD AXLE ROLLER BEARING
PULLER / INSTALLER**
Max. Capacity: 100 Tons Pulling
68 Tons Installing

INSTRUCTIONS REQUIRED TO PUT PULLER INTO SERVICE

NOTE: Before operating this puller, carefully follow all the steps given below.

- STEP 1.** Carefully read and understand the Safety Precautions and Operating Instructions on form numbers 102810, 102371, 102397, and 100412 attached. These safety precautions and operating instructions describe general safety precautions and the method required to connect the pump, hoses, fittings, and pulling cylinder. Since this puller has been completely assembled and tested at our factory, follow the succeeding steps to put the puller into service.
- STEP 2.** Carefully remove all packing materials from the assembled puller.
- STEP 3.** Fill pump reservoir to proper operating level using approved Power Team hydraulic oil.
- STEP 4.** Connect pump power cord to proper power source and lower puller cylinder to lowest position. Start pump and cycle pulling cylinder to full extension, then to full retraction, three or more times until the cylinder advances and retracts smoothly throughout the cycle.
- STEP 5.** Allow the pump to build to full pressure with the cylinder first fully extended, and then fully retracted. Stop pump and check each hose, fitting, and other system components for any oil leakage. If any leakage is found, correct the problem and retest.
- STEP 6.** Install proper tooling on puller and operate puller following the instructions for "Removing or Installing the Timken 'AP' or 'Hyatt Hy-roll Taper' Bearing (or similar)" as written on form number 102810 attached.

This page intentionally left blank.

Operating Instructions for:

PR2100J	PR3100J
PR2100J-50-220	PR3100J-50-380
PR2100S	PR3100S

MODEL C
**UNIVERSAL RAILROAD AXLE ROLLER BEARING
PULLER / INSTALLER**

Max. Capacity: 100 Tons Pulling
68 Tons Installing

- Carefully inspect the pump upon arrival. The carrier, not the manufacturer, is responsible for any damage resulting from shipment.
- These instructions should be read and carefully followed. Most problems with new equipment are caused by improper operation or installation.

SAFETY PRECAUTIONS

WARNING

- All WARNING statements must be carefully observed to help prevent personal injury. Keep these instructions at or near the machine location. Only qualified individuals should operate this equipment.

Hydraulic Hose

- Before operating the pump, tighten all hose connections using the proper tools. Do not overtighten the connections. Connections need only be tightened securely and leak-free. Overtightening may cause premature thread failure or high pressure fittings to split at pressures lower than their rated capacities.
- Should a hydraulic hose ever burst, rupture, or need to be disconnected, immediately shut off the pump. Never attempt to grasp a leaking hose under pressure with your hands. The force of the escaping hydraulic fluid could cause serious injury.
- Do not subject the hose to potential hazard such as fire, extreme heat or cold, sharp surfaces, or heavy impact. Do not allow the hose to kink, twist, curl or bend so tightly that the oil flow within the hose is blocked or reduced. Periodically inspect the hose for signs of wear because any of these conditions can damage the hose and may result in personal injury.
- Do not use the hose to move attached equipment. Stress may damage the hose and cause personal injury.
- Hose material and coupler seals must be compatible with the hydraulic fluid used. Hoses also must not come in contact with corrosive materials such as creosote-impregnated objects and some paints. Consult the manufacturer before painting a hose. Never paint the couplers. Hose deterioration due to corrosive materials may result in personal injury.

Pump

- Do not exceed the PSI hydraulic pressure rating noted on the pump nameplate or tamper with the internal high relief valve. Creating pressures beyond rated capacities may result in personal injury.
- Before replenishing the oil level, retract all cylinders to prevent overfilling the pump reservoir. An overfill may cause personal injury due to excess reservoir pressure created with cylinders are retracted.

Safety Precautions (continued)

General Operation

- Do not beat or hammer on or near any part of this unit! Sharp or sudden impacts can cause undue stress on highly loaded parts which can result in equipment damage or possible personal injury.
- Stand back as far as the remote control will allow during bearing removal or installation in case of part breakage.
- A qualified individual should carefully inspect the unit before each use. This individual should look for any abnormal condition that may present a potentially hazardous situation. If any abnormal condition is found, do not use the equipment until it is corrected and approved for use.
- It is the user's responsibility to wear protective equipment as dictated by federal, state or local laws. As a minimum, it is suggested that the operator and anyone else in the work area, wear safety glasses, safety shoes, and a hard hat.

OPERATING INSTRUCTIONS

HOSE CONNECTION

IMPORTANT: Seal all hydraulic connections with Power Team HTS6 thread sealant. Teflon tape can be used to seal hydraulic connections if only one layer of tape is used. Apply carefully, two threads back, to prevent it from being pinched by the coupler and broken off inside the system. Any loose pieces of tape could travel through the system and obstruct the flow of oil or cause jamming of precision-fit parts.

Hose connections should be done in the following sequence:

MODELS PR2100J, PR2100J-50-220, PR3100J, & PR3100J-50-380 (refer to illustration on sheet 2 of 4)

The units are supplied completely assembled.

1. Connect one 40 in. hose from port "A" to the pressure regulator valve.
2. Connect the other 40 in. hose from port "B" to the shut-off valve.
3. Operate the unit, with the cylinder in the lowest position, three or more times until it advances and retracts smoothly.

MODELS PR2100S & PR3100S (refer to illustration on sheet 2 of 4)

1. Connect the 2 ft. hose from port "A" to the pressure regulator valve.
2. Connect the 40 in. hose from port "B" to the shut-off valve.
3. Operate the unit three or more times until it advances and retracts smoothly.

NOTE: If hoses are connected wrong, the remote control switch will operate the cylinder in reverse of what the decal indicates.

EXTERNAL PRESSURE REGULATOR

The pressure regulator valve allows the operator of the bearing puller / installer to limit the pressure on the return stroke of the cylinder when the journal axle bearings are being installed.

The pressure regulator valve (#9623) has been set at 6,000 PSI. The maximum force (output) of the cylinder at 6,000 PSI when the piston is being retracted is 40 tons (with the shut-off valve open). If the maximum force of the cylinder is needed for bearing installation, the shut-off valve should be closed.

Adjusting the Pressure Regulator Valve (Refer to Parts List #101314)

NOTE: For easy adjustment of the pressure regulator valve, always adjust the pressure by INCREASING it to a desired pressure setting. The pressure range for this unit is 1,000 PSI to 10,000 PSI.

1. Loosen the locknut on the pressure regulator valve. Turn the adjusting screw a few turns counterclockwise (CCW) to decrease the pressure setting to a lower than desired pressure.
2. Open the shut-off valve.
3. Place the four-way control valve in the RETURN position.
4. Start the pump and build pressure on the return side of the #9623 valve. Slowly turn the adjusting screw in a clockwise (CW) direction to gradually increase the pressure setting. When the desired pressure setting is reached, lock the adjusting screw into position by tightening the locknut.

HYDRAULIC HOSE CONNECTION AND PRESSURE REGULATOR

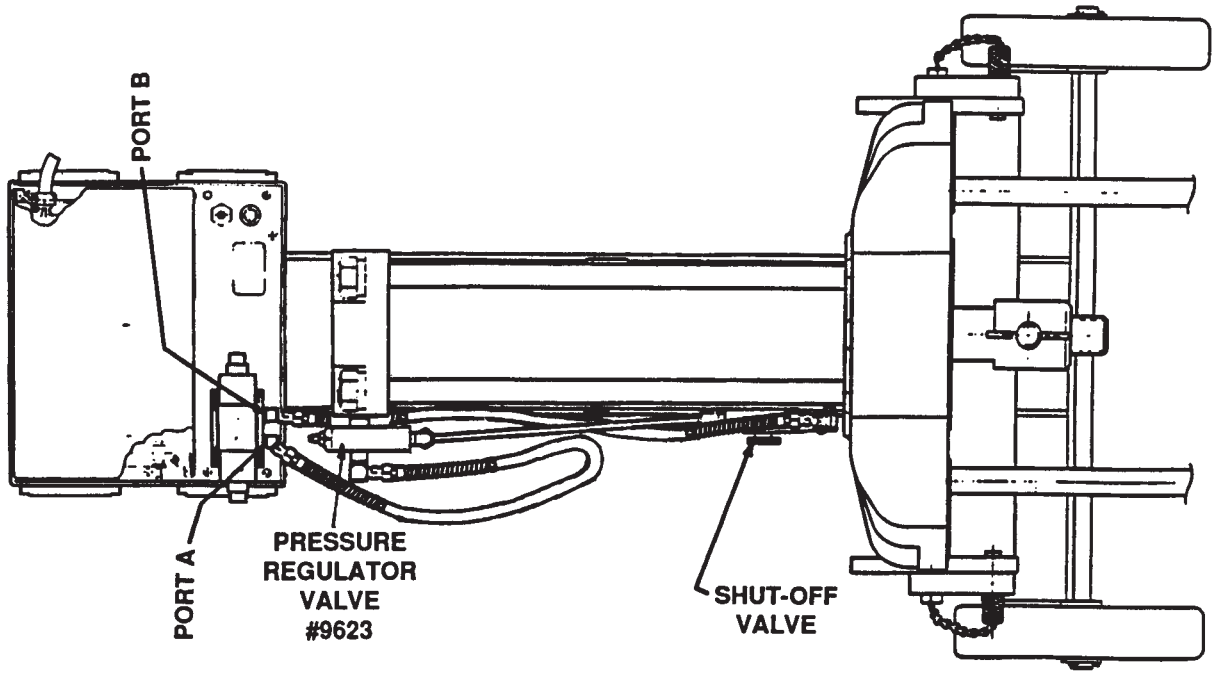

JACK TYPE PULLER

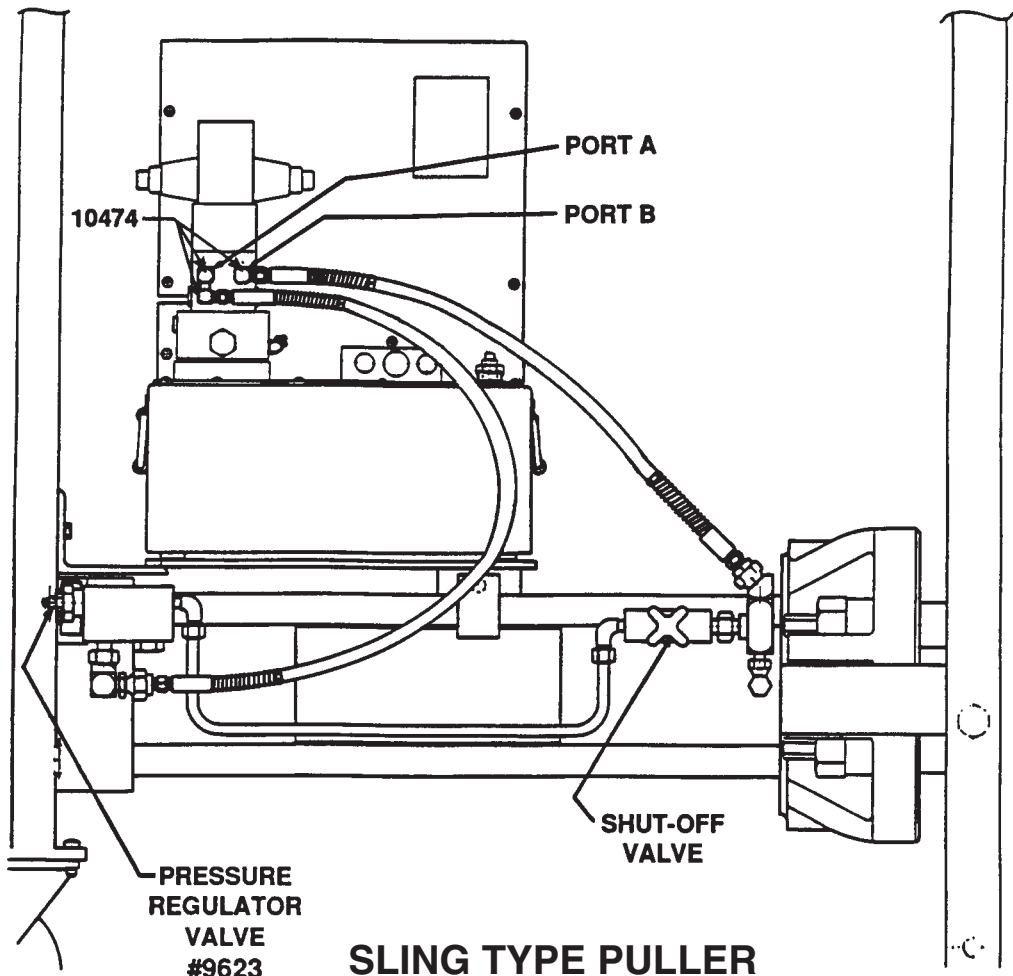

SLING TYPE PULLER

REMOVING OR INSTALLING THE TIMKEN "AP" OR "HYATT HY-ROLL TAPER" BEARING (OR SIMILAR)

Always follow the bearing manufacturer's installation or removal procedures. These guideline instructions are for typical application only.

NOTE: THE PHOTOGRAPHS USED IN THESE INSTRUCTIONS SHOW A Y4600-A IN ACTION, HOWEVER, THE PROCEDURE FOR USING THE PR2100J, PR2100J-50-220, PR2100S, PR3100J, PR3100J-50-380, OR PR3100S IS IDENTICAL UNLESS OTHERWISE NOTED.

The instructions that follow cover a typical application involving the use of a Power Team Bearing Puller / Installer, and illustrate the steps necessary to remove and install roller bearings with this unit. The adapters and accessories which will be required to remove and install these bearings will be determined by Power Team when furnished with the following information concerning the particular bearing to be serviced: Bearing manufacturer's name; bearing manufacturer's general arrangement drawing number; size of bearing to be serviced; railroad name and location; and part number of the adapters which are in your possession if you presently own a puller / installer.

BEARING REMOVAL OPERATION

TO REMOVE A BEARING FROM AN AXLE (WHEN ONLY A FEW ARE TO BE REMOVED)

Refer to the bearing manufacturer's service manual for steps to be taken prior to the actual removal of the bearing.

Select the proper Pulling Shoe and attach it to the Pulling Frame Legs if this has not already been done (Figure 1).

Attach the Guide Tube to the end of the axle with the Cap Screws provided (Figure 2). Do not tighten bolts.

Insert the Guide Tube Adapter into the threaded hole in the Guide Tube. The Guide Tube Adapter is retained by a spring-loaded ball and is not threaded (Figure 3).

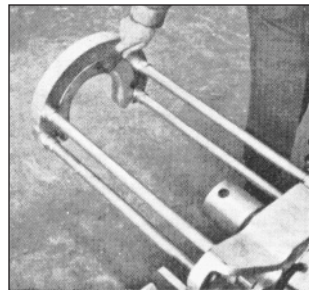

FIGURE 1

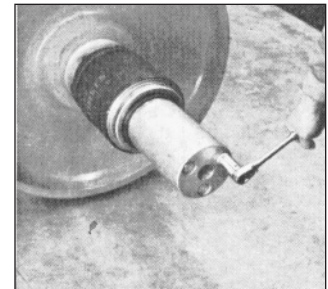

FIGURE 2

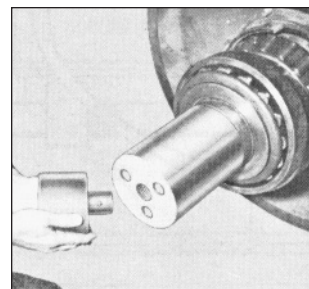

FIGURE 3

Roll the Bearing Puller / Installer into position. Remove the Pulling Frame Stop Pins and tilt the Pulling Frame so that it is positioned directly above the Bearing Assembly. Place the Forcing Plug Adapter in the Piston Rod Coupling (Figure 4).

Lower the Pulling Frame so that the Pulling Shoe fits behind the bearing backing ring and replace the Pulling Frame Stop Pins, making certain that the Bearing Puller / Installer is in alignment with the axle. It may be necessary to adjust the Pulling Frame for height to assure correct vertical alignment of the Bearing Puller / Installer. After adjusting Pulling Frame for height, hold the Pulling Shoe in position behind the bearing backing ring until initial pressure has been applied to the bearing assembly (Figure 5).

If the Pulling Shoe is engaging the bearing backing ring properly and the entire setup is properly aligned (Figure 6), stand back as far as the remote control will allow and continue to apply pressure, extending the Piston Rod until the bearing assembly has been removed from the axle and is resting on the Guide Tube.

When the bearing assembly is removed from the Guide Tube, a cardboard tube, similar to the shipping tube which originally accompanied the bearing assembly, should be used to hold the internal bearing parts in place. Particular attention should be given to keeping the seal wear rings in place in the enclosure seals.

TO REMOVE A BEARING ASSEMBLY FROM AN AXLE (WHEN NUMEROUS BEARING ASSEMBLIES OF THE SAME SIZE ARE TO BE REMOVED)

Upon determining the bearing size, select the proper Pulling Shoe Insert Adapter and attach it to the Pulling Shoe (Figure 7).

Attach the Guide Tube to the Piston Rod Coupling by threading the Installing Adapter into the Guide Tube (Figure 8) and attaching this assembly to the Piston Rod Coupling with the Connector Pin (Figure 9), making certain that the Guide Tube is tightened against the Piston Rod Coupling so that the pressure required to remove the bearing assembly will not shear or bend the Connector Pin.

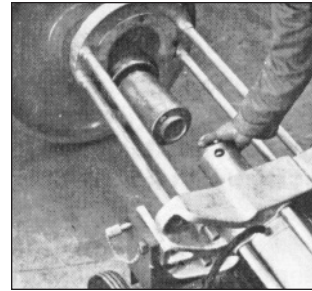

FIGURE 4

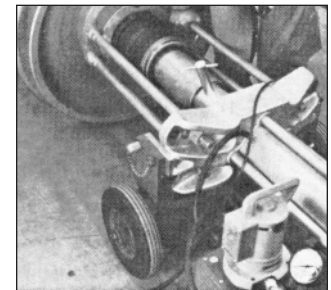

FIGURE 5

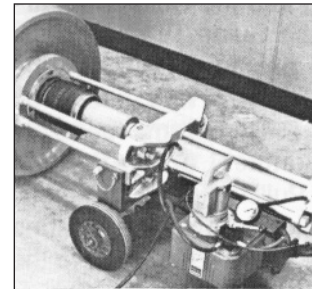

FIGURE 6

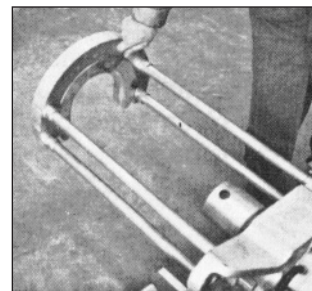

FIGURE 7

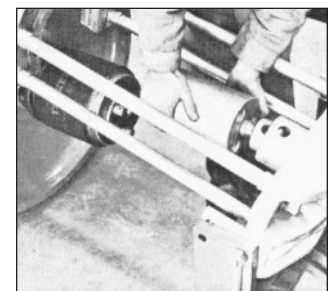

FIGURE 8

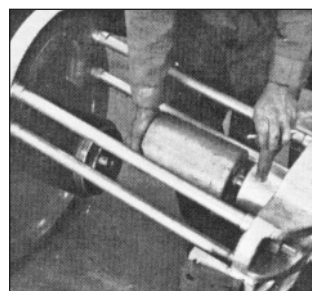

FIGURE 9

Thread two Guide Pins into the axle to align the Guide Tube with the axle for the pulling operation (Figure 10).

NOTE: Guide Pins are not supplied or catalogued by Power Team. Guide Pins are strictly a user part and must be determined by the user.

Roll the Bearing Puller / Installer into position. Remove the Pulling Frame Stop Pins and tilt the Pulling Frame so that it is positioned directly above the Bearing Assembly (Figure 11).

Lower the Pulling Frame so that the Pulling Shoe fits behind the bearing backing ring and the Guide Pins are in alignment with the holes in the Guide Tube. Replace the Pulling Frame Stop Pins, making certain that the Bearing Puller / Installer is in alignment with the axle. It may be necessary to adjust the Pulling Frame for height to assure correct vertical adjustment of the Bearing Puller / Installer. After adjusting Pulling Frame for height, hold the Pulling Shoe in position behind the bearing backing ring until initial pressure has been applied to the bearing assembly (Figure 12).

If the Pulling Shoe is engaging the bearing backing ring properly and the entire setup is properly aligned (Figure 13), stand back as far as the remote control will allow and continue to apply pressure, extending the Piston Rod until the bearing assembly has been removed from the axle and is resting on the Guide Tube (Figure 14).

When the bearing assembly is removed from the Guide Tube, a cardboard tube, similar to the shipping tube which originally accompanied the bearing assembly, should be used to hold the internal bearing parts in place. Particular attention should be given to keeping the seal wear rings in place in the enclosure seals.

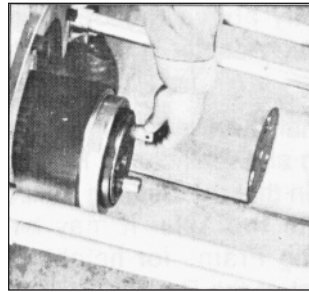

FIGURE 10

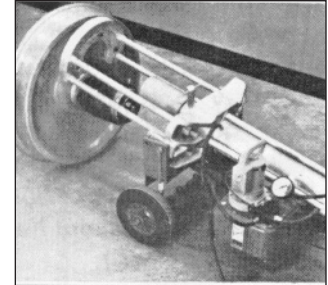

FIGURE 11

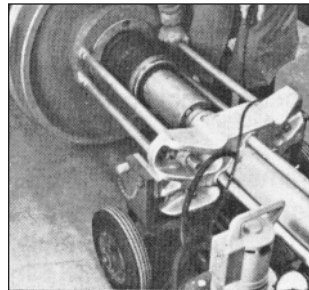

FIGURE 12

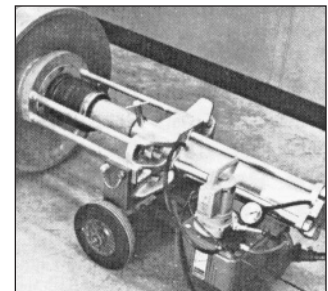

FIGURE 13

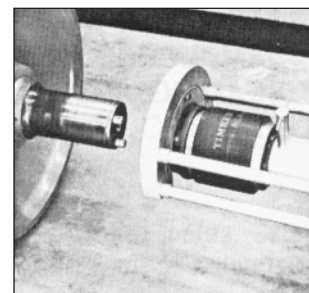

FIGURE 14

BEARING ASSEMBLY INSTALLATION OPERATION

The axle should be checked for size and condition before bearing assemblies are reinstalled. (Check the bearing manufacturer's service manual for steps and procedures to be taken in checking the axle.) Any undesirable conditions such as upset ends, high spots, or blemishes should be corrected.

TO INSTALL A BEARING ASSEMBLY ON AN AXLE

Attach the Guide Tube to the end of the axle with the cap screws provided (Figure 15). If a large number of bearing assemblies are to be installed, at least two Guide Tubes should be used to facilitate more efficient production. **NOTE: Do not tighten Guide Tube bolts, see rule 5.47 of AAR Manual.**

Thread the Installing Adapter into the Guide Tube (Figure 16).

Coat the bearing seats of the axle with castor oil, heavy mineral oil, a Molykote and oil mixture, or as directed by the bearing manufacturer (Figure 17). **NOTE: DO NOT USE WHITE LEAD. Lead compounds act as an oxidation catalyst in lubricating greases.**

Slip the bearing assembly on the Guide Tube. The seal wear ring should be held in place to prevent it from riding out of the enclosure seal when the cardboard tube is ejected. A small lift is recommended for handling the larger bearing assembly sizes (Figure 18).

Place the Installing Tube Adapter Ring in position against the outer seal wear ring. Make certain that the Installing Tube Adapter Ring is properly positioned on the Guide Tube to receive the Installing Tube (Figure 19). **MAKE CERTAIN THAT THE INSTALLING TUBE ADAPTER RING IS NOT REVERSED!**

If the Pulling Shoe Insert Adapter has not been previously detached from the Pulling Shoe, detach it. Bearing assembly installation cannot be accomplished with the Pulling Shoe Insert Adapter attached to the Pulling Shoe (Figure 20).

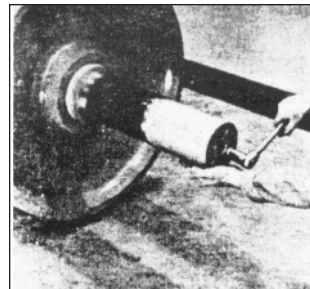

FIGURE 15

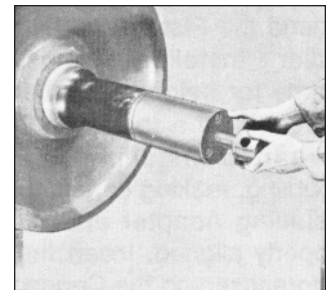

FIGURE 16

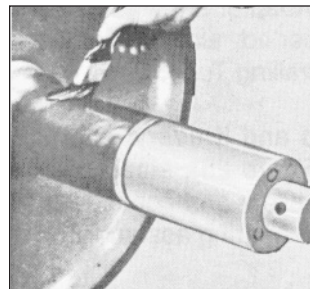

FIGURE 17

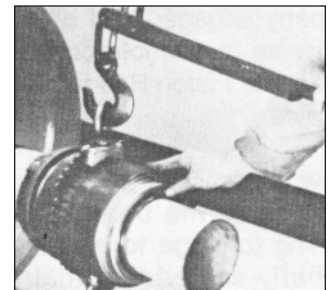

FIGURE 18

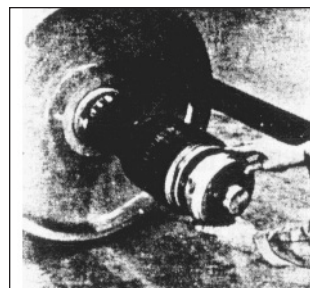

FIGURE 19



FIGURE 20

Place the Installing Tube Cradles between the lower arms of the Pulling Frame (Figure 21).

Place the Installing Tube on the Installing Tube Cradles (Figure 22). **MAKE CERTAIN THE INSTALLING TUBE IS FACING IN THE RIGHT DIRECTION AND IS NOT REVERSED!**

Regulate the Installing Tube Cradle Adjusting screws to properly align the Installing Tube with the recess in the Hydraulic Ram Mounting Plate so that they will engage correctly (Figure 23). Normally this adjustment need only be made once and is not necessary each time a bearing assembly of the same size is to be installed.

Extend the Piston Rod completely and roll the Bearing Puller / Installer into position, adjusting the Pulling Frame for height, if necessary. Engage the Installing Tube with the Installing Tube Adapter Ring and the Threaded Installing Adapter with the Piston Rod Coupling, making certain that the holes in the Threaded Installing Adapter and the Piston Rod Coupling are properly aligned. Insert the Connector Pin (Figure 24). Before inserting the Connector Pin, it may be necessary to adjust the Threaded Installing Adapter a few turns so that the Connector Pin, when inserted, almost touches the end of the guide slot in the Installing Tube.

Begin to retract the Piston Rod and if everything is properly engaged and aligned (Figure 25), stand back as far as the remote control will allow and continue to retract the Piston Rod to press the bearing assembly on the axle.

Allow the pressure registered on the Pressure gauge to build up to the bearing manufacturer's suggested seating tonnage to insure that the bearing parts are properly seated and that the backing ring is firmly seated against the axle fillet.

After the bearing assembly has been pressed on the axle, remove the Bearing Puller / Installer and rotate the bearing assembly to make sure that it will turn.

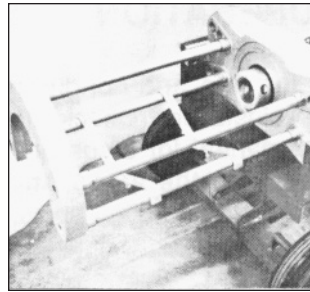

FIGURE 21

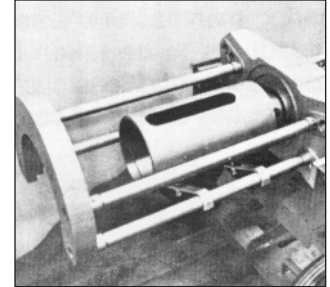

FIGURE 22

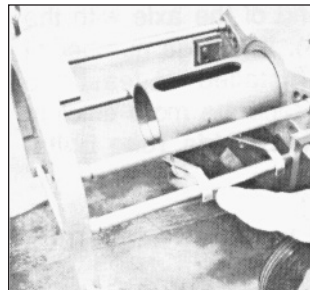

FIGURE 23

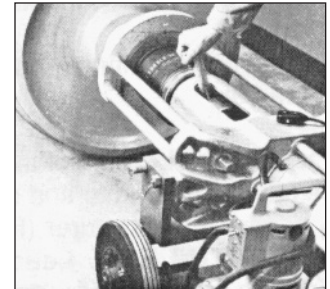

FIGURE 24

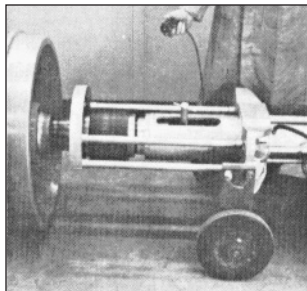

FIGURE 25