

# FLAT RING STRIKING WRENCHES

**OZAT**  
2000 LTD.

QUALITY POWER TOOLS

(HAMMER WRENCHES, SLOGGING WRENCHES)

A/F

DIN 7444

NOMINAL OPENING	D	L	H	Weight		
A/F Inch	WHIT	CATALOG No.	mm	mm	mm	gr
5/8"		FSW10	40	140	17	288
11/16"		FSW11	40	140	17	288
3/4"		FSW12	40	140	17	288
13/16"		FSW13	40	140	17	288
7/8"		FSW14	47	185	17	390
15/16"		FSW15	47	185	17	390
1"		FSW16	47	185	17	390
	9/16"W	FSWW09	47	185	17	390
1 1/6"		FSW17	47	185	17	390
	5/8"W	FSWW10	54	190	17	430
1 1/8"		FSW18	54	190	17	430
1 3/16"		FSW19	54	190	17	430
	11/16"W	FSWW11	54	190	17	430
1 1/4"		FSW20	54	190	17	430
	3/4"W	FSWW12	54	190	17	430
1 5/16"		FSW21	54	190	17	430
1 3/8"		FSW22	60	190	17	650
	13/16"W	FSWW13	60	190	17	650
1 7/16"		FSW23	66	215	22	800
	7/8"W	FSWW14	66	215	22	800
1 1/2"		FSW24	66	215	22	800
1 9/16"		FSW25	66	215	22	800
	15/16"W	FSWW15	66	215	22	800
1 5/8"		FSW26	66	215	22	800
	1"W	FSWW16	74	240	23	1000
1 11/16"		FSW27	74	240	23	1000
1 3/4"		FSW28	74	240	23	1000
	1 1/16"W	FSWW17	74	240	23	1000
1 13/16"		FSW29	74	240	23	1000
	1 1/8"W	FSWW18	74	240	23	1000
1 7/8"		FSW30	74	240	23	1000
1 15/16"		FSW31	74	240	23	1000
2"		FSW32	86	270	25	1800
	1 1/4"W	FSWW20	86	270	25	1800
2 1/16"		FSW33	86	270	25	1800
2 1/8"		FSW34	86	270	25	1800
2 3/16"		FSW35	94	270	25	1800
	1 3/8"W	FSWW22	94	270	25	1800
2 1/4"		FSW36	94	270	25	1800
2 5/16"		FSW37	94	270	25	1800
2 3/8"		FSW38	102	300	30	2500
	1 1/2"W	FSWW24	102	300	30	2500
2 7/16"		FSW39	102	300	30	2500
2 1/2"		FSW40	102	300	30	2500
2 9/16"		FSW41	102	300	30	2500
	1 5/8"W	FSWW26	102	300	30	2500
2 5/8"		FSW42	102	300	30	2500
2 11/16"		FSW43	102	300	30	2500
2 3/4"		FSW44	115	330	33	3400
	1 3/4"W	FSWW28	115	330	33	3400
2 13/16"		FSW45	115	330	33	3400
2 7/8"		FSW46	115	330	33	3400
2 15/16"		FSW47	115	330	33	3400
3"		FSW48	115	330	33	3400
	1 7/8"W	FSWW30	115	330	33	3400
3 1/16"		FSW49	115	330	33	3400
3 1/8"		FSW50	125	360	36	3900
	2"W	FSWW32	125	360	36	3900
3 3/16"		FSW51	125	360	36	3900
3 1/4"		FSW52	125	360	36	3900
3 5/16"		FSW53	125	360	36	3900
3 3/8"	2 1/8"W	FSW54W34	142	390	40	6100
3 7/16"		FSW55	142	390	40	6100
3 1/2"		FSW56	142	390	40	6100
	2 1/4"W	FSWW36	142	390	40	6100
3 9/16"		FSW57	142	390	40	6100
3 5/8"		FSW58	142	390	40	6100
3 11/16"		FSW59	142	390	40	6100
3 3/4"	2 3/8"W	FSW60W38	142	390	40	6100
3 13/16"		FSW61	142	390	40	6100
3 7/8"		FSW62	155	420	45	7000
	2 1/2"W	FSWW40	155	420	45	7000
3 15/16"		FSW63	155	420	45	7000
4"		FSW64	155	420	45	7000
4 1/16"	2 5/8"W	FSW65W42	155	420	45	7000
4 1/8"		FSW66	155	420	45	7000
4 3/16"	2 3/4"W	FSW67W44	155	420	45	7000
4 1/4"		FSW68	170	450	48	9500
4 5/16"	2 7/8"W	FSW69W46	170	450	48	9500
4 3/8"		FSW70	170	450	48	9500
4 7/16"		FSW71	170	450	48	9500
4 1/2"		FSW72	170	450	48	9500
4 9/16"		FSW73	170	450	48	9500
	3"W	FSWW48	170	450	48	9500
4 5/8"		FSW74	170	450	48	9500
4 11/16"		FSW75	185	475	54	10500
4 3/4"		FSW76	185	475	54	10500

chart to be continued

(HAMMER WRENCHES, SLOGGING WRENCHES)

A/F

DIN 7444

NOMINAL OPENING	D	L	H	Weight		
A/F Inch	WHIT	CATALOG No.	mm	mm	mm	gr
4 13/16"		FSW77	185	475	54	10500
	3 1/4"W	FSWW52	185	475	54	10500
4 7/8"		FSW78	185	475	54	10500
4 15/16"		FSW79	185	475	54	10500
5"		FSW80	185	475	54	10500
5 1/16"		FSW81	185	475	54	10500
5 1/8"	3 1/8"W	FSW82W54	202	530	58	13000
	3 1/2"W	FSWW56	202	530	58	13000
5 3/16"		FSW83	202	530	58	13000
5 1/4"		FSW84	202	530	58	13000
5 5/16"		FSW85	202	530	58	13000
5 3/8"		FSW86	202	530	58	13000
5 1/2"		FSW88	202	530	58	13000
5 5/8"		FSW90	202	530	58	13000
5 3/4"	3 7/8"W	FSW92W62	225	580	64	19000
5 7/8"		FSW94	225	580	64	19000
6"		FSW96	225	580	64	19000
6 1/8"		FSW98	225	580	64	19000
6 1/4"		FSW100	225	580	64	19000
6 3/8"		FSW102	225	580	64	19000
6 1/2"		FSW104	265	650	70	27000
6 5/8"		FSW106	265	650	70	27000
6 3/4"		FSW108	265	650	70	27000
6 7/8"		FSW110	265	650	70	27000
7"		FSW112	265	650	70	27000

Other sizes available

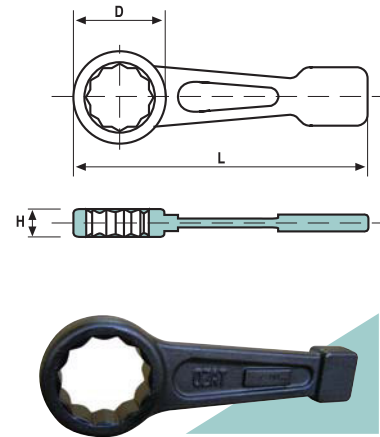

(HAMMER WRENCHES, SLOGGING WRENCHES)

Metric

DIN 7444

NOMINAL OPENING	D	L	H	Weight	
mm	CATALOG No.	mm	mm	mm	gr
16	FSWM16	40	140	17	288
17	FSWM17	40	140	17	288
18	FSWM18	40	140	17	288
19	FSWM19	40	140	17	288
20	FSWM20	40	140	17	288
21	FSWM21	40	140	17	288
22	FSWM22	47	185	17	390
23	FSWM23	47	185	17	390
24	FSWM24	47	185	17	390
25	FSWM25	47	185	17	390
26	FSWM26	47	185	17	390
27	FSWM27	47	185	17	390
28	FSWM28	54	190	17	430
29	FSWM29	54	190	17	430
30	FSWM30	54	190	17	430
31	FSWM31	54	190	17	430

chart to be continued in the next page

# FLAT RING STRIKING WRENCHES

**OZAT**  
2000 LTD.

(HAMMER WRENCHES, SLOGGING WRENCHES)

Metric

DIN 7444

chart continued

NOMINAL OPENING		D	L	H	Weight
mm	CATALOG No.	mm	mm	mm	gr
32	FSWM32	54	190	17	430
33	FSWM33	54	190	17	430
34	FSWM34	54	190	17	430
35	FSWM35	54	190	17	430
36	FSWM36	60	190	17	650
37	FSWM37	66	215	22	800
38	FSWM38	66	215	22	800
39	FSWM39	66	215	22	800
40	FSWM40	66	215	22	800
41	FSWM41	66	215	22	800
42	FSWM42	74	240	23	800
43	FSWM43	74	240	23	800
44	FSWM44	74	240	23	800
45	FSWM45	74	240	23	800
46	FSWM46	74	240	23	800
47	FSWM47	74	240	23	800
48	FSWM48	74	240	23	800
49	FSWM49	74	240	23	800
50	FSWM50	74	240	23	800
51	FSWM51	86	270	25	1800
52	FSWM52	86	270	25	1800
54	FSWM54	86	270	25	1800
55	FSWM55	86	270	25	1800
56	FSWM56	94	270	25	1800
57	FSWM57	94	270	25	1800
58	FSWM58	94	270	25	1800
59	FSWM59	94	270	25	1800
60	FSWM60	94	270	25	1800
61	FSWM61	102	300	30	2500
62	FSWM62	102	300	30	2500
65	FSWM65	102	300	30	2500
67	FSWM67	102	300	30	2500
70	FSWM70	115	330	33	3400
72	FSWM72	115	330	33	3400
73	FSWM73	115	330	33	3400
75	FSWM75	115	330	33	3400
76	FSWM76	115	330	33	3400
77	FSWM77	115	330	33	3400
80	FSWM80	125	360	36	3900
82	FSWM82	125	360	36	3900
85	FSWM85	125	360	36	3900
86	FSWM86	142	390	40	3900
87	FSWM87	142	390	40	3900
90	FSWM90	142	390	40	3900
95	FSWM95	142	390	40	3900
100	FSWM100	155	420	45	6100
105	FSWM105	155	420	45	6100
110	FSWM110	170	450	48	9500
115	FSWM115	170	450	48	9500
120	FSWM120	185	475	54	10500
125	FSWM125	185	475	54	10500
130	FSWM130	202	530	58	13000
135	FSWM135	202	530	58	13000
140	FSWM140	202	530	58	13000
145	FSWM145	225	580	64	19000
150	FSWM150	225	580	64	19000
155	FSWM155	225	580	64	19000
160	FSWM160	225	580	64	19000
165	FSWM165	265	650	70	27000
170	FSWM170	265	650	70	27000
175	FSWM175	265	650	70	27000
180	FSWM180	265	650	70	27000
190	FSWM190	290	700	75	33000
200	FSWM200	290	700	75	33000
210	FSWM210	320	750	80	38000
220	FSWM220	320	750	80	38000
230	FSWM230	320	750	80	38000

Other sizes available

6 point also available on request

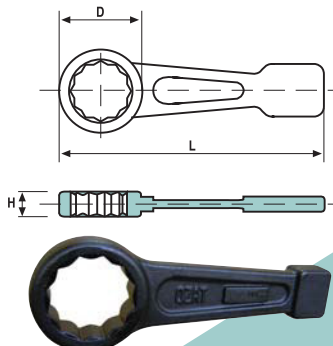

## FLAT STRIKING WRENCH ADAPTOR

CATALOG No.	MALE SD	FEMALE SD	D	L	H	Weight
			mm	mm	mm	gr
FSA0808	1/2"	1/2"	60	190	40	790
FSA0812	3/4"	1/2"	66	215	60	1210
FSA1212	3/4"	3/4"	66	215	60	1210
FSA0816	1"	1/2"	86	270	76	2620
FSA1216	1"	3/4"	86	270	76	2620
FSA1616	1"	1"	86	270	76	2620
FSA1224	1 1/2"	3/4"	102	300	100	3970
FSA1624	1 1/2"	1"	102	300	100	3970
FSA2424	1 1/2"	1 1/2"	102	300	100	3970

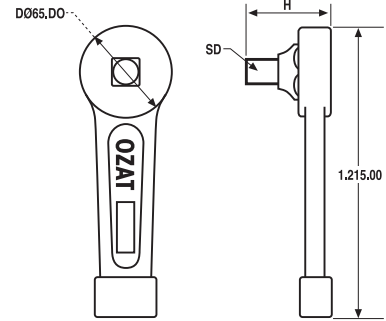

QUALITY POWER TOOLS

# OFFSET RING STRIKING WRENCHES

**OZAT**  
2000 LTD.

QUALITY POWER TOOLS

 (Hammer Wrenches, Slogging Wrenches)

Metric

NOMINAL OPENING mm	CAT No.	D mm	L mm	H mm	Weight gr
19	OSWM19	52	304	21	1980
20	OSWM20	52	304	21	1980
21	OSWM21	52	304	21	1980
22	OSWM22	52	304	21	1980
23	OSWM23	52	304	21	1980
24	OSWM24	52	304	21	1980
25	OSWM25	52	304	21	1980
26	OSWM26	52	304	21	1980
27	OSWM27	52	304	21	1980
28	OSWM28	52	304	21	1980
29	OSWM29	52	304	21	1980
30	OSWM30	52	304	21	1980
31	OSWM31	52	304	21	1980
32	OSWM32	52	304	21	1980
33	OSWM33	52	304	21	1980
34	OSWM34	52	304	21	1980
35	OSWM35	52	304	21	1980
36	OSWM36	60	314	27	2400
38	OSWM38	66	314	27	2400
39	OSWM39	66	314	27	2400
40	OSWM40	66	314	27	2400
41	OSWM41	66	314	27	2400
42	OSWM42	66	314	27	2400
43	OSWM43	66	314	27	2400
44	OSWM44	66	314	27	2400
45	OSWM45	66	314	27	2400
46	OSWM46	66	314	27	2400
47	OSWM47	78	378	32	3950
48	OSWM48	78	378	32	3950
49	OSWM49	78	378	32	3950
50	OSWM50	78	378	32	3950
51	OSWM51	78	378	32	3950
52	OSWM52	78	378	32	3950
54	OSWM54	78	378	32	3950
55	OSWM55	78	378	32	3950
57	OSWM57	110	406	42	5930
58	OSWM58	110	406	42	5930
60	OSWM60	110	406	42	5930
65	OSWM65	110	406	42	5930
70	OSWM70	110	406	42	5930
75	OSWM75	110	406	42	5930
76	OSWM76	130	450	55	11850
80	OSWM80	130	450	55	11850
85	OSWM85	130	450	55	11850
86	OSWM86	130	450	55	11850
90	OSWM90	130	450	55	11850
95	OSWM95	155	500	65	16630
100	OSWM100	155	500	65	16630
105	OSWM105	155	500	65	16630
110	OSWM110	155	500	65	16630
115	OSWM115	155	500	65	16630

6 point also available on request

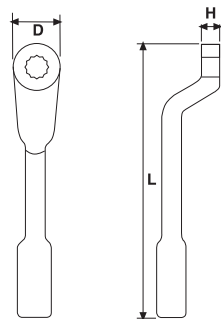

 (Hammer Wrenches, Slogging Wrenches)

A/F

NOMINAL OPENING A/F Inch	CAT No.	D mm	L mm	H mm	Weight gr
3/4"	OSW12	52	304	21	1980
13/16"	OSW13	52	304	21	1980
7/8"	OSW14	52	304	21	1980
15/16"	OSW15	52	304	21	1980
1"	OSW16	52	304	21	1980
1 1/16"	OSW17	52	304	21	1980
1 1/8"	OSW18	52	304	21	1980
1 3/16"	OSW19	52	304	21	1980
1 1/4"	OSW20	52	304	21	1980
1 5/16"	OSW21	52	304	21	1980
1 3/8"	OSW22	52	304	21	1980
1 7/16"	OSW23	60	314	27	2400
1 1/2"	OSW24	66	314	27	2400
1 9/16"	OSW25	66	314	27	2400
1 5/8"	OSW26	66	314	27	2400
1 11/16"	OSW27	66	314	27	2400
1 3/4"	OSW28	66	314	27	2400
1 13/16"	OSW29	66	314	27	2400
1 7/8"	OSW30	78	378	32	3950
1 15/16"	OSW31	78	378	32	3950
2"	OSW32	78	378	32	3950
2 1/16"	OSW33	78	378	32	3950
2 1/8"	OSW34	78	378	32	3950
2 3/16"	OSW35	78	378	32	3950
2 1/4"	OSW36	110	406	42	5930
2 5/16"	OSW37	110	406	42	5930
2 3/8"	OSW38	110	406	42	5930
2 7/16"	OSW39	110	406	42	5930
2 1/2"	OSW40	110	406	42	5930
2 9/16"	OSW41	110	406	42	5930
2 5/8"	OSW42	110	406	42	5930
2 11/16"	OSW43	110	406	42	5930
2 3/4"	OSW44	110	406	42	5930
2 13/16"	OSW45	110	406	42	5930
2 15/16"	OSW46	110	406	42	5930
3"	OSW47	110	406	42	5930
3 1/16"	OSW48	110	406	42	5930
3 1/8"	OSW50	130	450	55	11850
3 3/16"	OSW51	130	450	55	11850
3 1/4"	OSW52	130	450	55	11850
3 5/16"	OSW53	130	450	55	11850
3 3/8"	OSW54	130	450	55	11850
3 7/16"	OSW55	130	450	55	11850
3 1/2"	OSW56	130	450	55	11850
3 9/16"	OSW57	130	450	55	11850
3 5/8"	OSW58	130	450	55	11850
3 11/16"	OSW59	130	450	55	11850
3 3/4"	OSW60	155	500	65	16630
3 13/16"	OSW61	155	500	65	16630
3 7/8"	OSW62	155	500	65	16630
3 15/16"	OSW63	155	500	65	16630
4"	OSW64	155	500	65	16630
4 1/16"	OSW65	155	500	65	16630
4 1/8"	OSW66	155	500	65	16630
4 3/16"	OSW67	155	500	65	16630
4 1/4"	OSW68	155	500	65	16630
4 5/16"	OSW69	155	500	65	16630
4 3/8"	OSW70	155	500	65	16630
4 7/16"	OSW71	155	500	65	16630
4 1/2"	OSW72	155	500	65	16630
4 9/16"	OSW73	155	500	65	16630

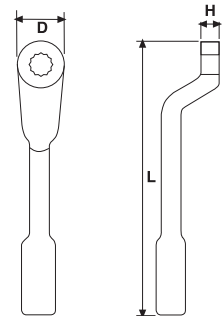

**(Hammer Wrenches, Slogging Wrenches)**  
Metric

NOMINAL OPENING		D	L	H	Weight
mm	CAT No.	mm	mm	mm	gr
19	SOSWM19	52	304	21	1980
20	SOSWM20	52	304	21	1980
21	SOSWM21	52	304	21	1980
22	SOSWM22	52	304	21	1980
23	SOSWM23	52	304	21	1980
24	SOSWM24	52	304	21	1980
25	SOSWM25	52	304	21	1980
26	SOSWM26	52	304	21	1980
27	SOSWM27	52	304	21	1980
28	SOSWM28	52	304	21	1980
29	SOSWM29	52	304	21	1980
30	SOSWM30	52	304	21	1980
31	SOSWM31	52	304	21	1980
32	SOSWM32	52	304	21	1980
33	SOSWM33	52	304	21	1980
34	SOSWM34	52	304	21	1980
35	SOSWM35	52	304	21	1980
36	SOSWM36	66	314	27	2400
38	SOSWM38	66	314	27	2400
39	SOSWM39	66	314	27	2400
40	SOSWM40	66	314	27	2400
41	SOSWM41	66	314	27	2400
42	SOSWM42	66	314	27	2400
43	SOSWM43	66	314	27	2400
44	SOSWM44	66	314	27	2400
45	SOSWM45	66	314	27	2400
46	SOSWM46	66	314	27	2400
47	SOSWM47	78	378	32	3950
48	SOSWM48	78	378	32	3950
49	SOSWM49	78	378	32	3950
50	SOSWM50	78	378	32	3950
51	SOSWM51	78	378	32	3950
52	SOSWM52	78	378	32	3950
54	SOSWM54	78	378	32	3950
55	SOSWM55	78	378	32	3950
57	SOSWM57	110	406	42	5930
58	SOSWM58	110	406	42	5930
60	SOSWM60	110	406	42	5930
65	SOSWM65	110	406	42	5930
70	SOSWM70	110	406	42	5930
75	SOSWM75	110	406	42	5930
76	SOSWM76	130	450	55	11850
80	SOSWM80	130	450	55	11850
85	SOSWM85	130	450	55	11850
86	SOSWM86	130	450	55	11850
90	SOSWM90	130	450	55	11850
95	SOSWM95	155	500	65	16630
100	SOSWM100	155	500	65	16630
105	SOSWM105	155	500	65	16630
110	SOSWM110	155	500	65	16630
115	SOSWM115	155	500	65	16630

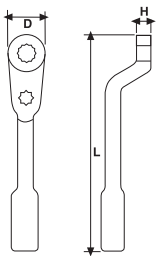

**SAFETY HANDLE**

NOMINAL OPENING	CATALOG No.	Weight
		gr
1/2"X400mm	SOSWH400	550



**(Hammer Wrenches, Slogging Wrenches)**  
A/F

NOMINAL OPENING		D	L	H	Weight
A/F Inch	CAT No.	mm	mm	mm	gr
3/4"	SOSW12	52	304	21	1980
13/16"	SOSW13	52	304	21	1980
7/8"	SOSW14	52	304	21	1980
15/16"	SOSW15	52	304	21	1980
1"	SOSW16	52	304	21	1980
1 1/16"	SOSW17	52	304	21	1980
1 1/8"	SOSW18	52	304	21	1980
1 3/16"	SOSW19	52	304	21	1980
1 1/4"	SOSW20	52	304	21	1980
1 5/16"	SOSW21	52	304	21	1980
1 3/8"	SOSW22	52	304	21	1980
1 7/16"	SOSW23	66	314	27	2400
1 1/2"	SOSW24	66	314	27	2400
1 9/16"	SOSW25	66	314	27	2400
1 5/8"	SOSW26	66	314	27	2400
1 11/16"	SOSW27	66	314	27	2400
1 3/4"	SOSW28	66	314	27	2400
1 13/16"	SOSW29	66	314	27	2400
1 7/8"	SOSW30	78	378	32	3950
1 15/16"	SOSW31	78	378	32	3950
2"	SOSW32	78	378	32	3950
2 1/16"	SOSW33	78	378	32	3950
2 1/8"	SOSW34	78	378	32	3950
2 3/16"	SOSW35	78	378	32	3950
2 1/4"	SOSW36	110	406	42	5930
2 5/16"	SOSW37	110	406	42	5930
2 3/8"	SOSW38	110	406	42	5930
2 7/16"	SOSW39	110	406	42	5930
2 1/2"	SOSW40	110	406	42	5930
2 9/16"	SOSW41	110	406	42	5930
2 5/8"	SOSW42	110	406	42	5930
2 11/16"	SOSW43	110	406	42	5930
2 3/4"	SOSW44	110	406	42	5930
2 13/16"	SOSW45	110	406	42	5930
2 7/8"	SOSW46	110	406	42	5930
2 15/16"	SOSW47	110	406	42	5930
3"	SOSW48	110	406	42	5930
3 1/8"	SOSW50	130	450	55	11850
3 3/16"	SOSW51	130	450	55	11850
3 1/4"	SOSW52	130	450	55	11850
3 5/16"	SOSW53	130	450	55	11850
3 3/8"	SOSW54	130	450	55	11850
3 7/16"	SOSW55	130	450	55	11850
3 1/2"	SOSW56	130	450	55	11850
3 9/16"	SOSW57	130	450	55	11850
3 5/8"	SOSW58	130	450	55	11850
3 11/16"	SOSW59	130	450	55	11850
3 3/4"	SOSW60	155	500	65	16630
3 13/16"	SOSW61	155	500	65	16630
3 7/8"	SOSW62	155	500	65	16630
3 15/16"	SOSW63	155	500	65	16630
4"	SOSW64	155	500	65	16630
4 1/16"	SOSW65	155	500	65	16630
4 1/8"	SOSW66	155	500	65	16630
4.1875"	SOSW67	155	500	65	16630
4 1/4"	SOSW68	155	500	65	16630
4 5/16"	SOSW69	155	500	65	16630
4 3/8"	SOSW70	155	500	65	16630
4 7/16"	SOSW71	155	500	65	16630
4 1/2"	SOSW72	155	500	65	16630
4 9/16"	SOSW73	155	500	65	16630

