

Parts List for:

PH553C
PH553C13
PH553C-230
PH553C13-230

PH553CL
PH553CL13
PH553CL-230
PH553CL13-230

CART MOUNTED 55 TON HYDRAULIC PULLER ASSEMBLY

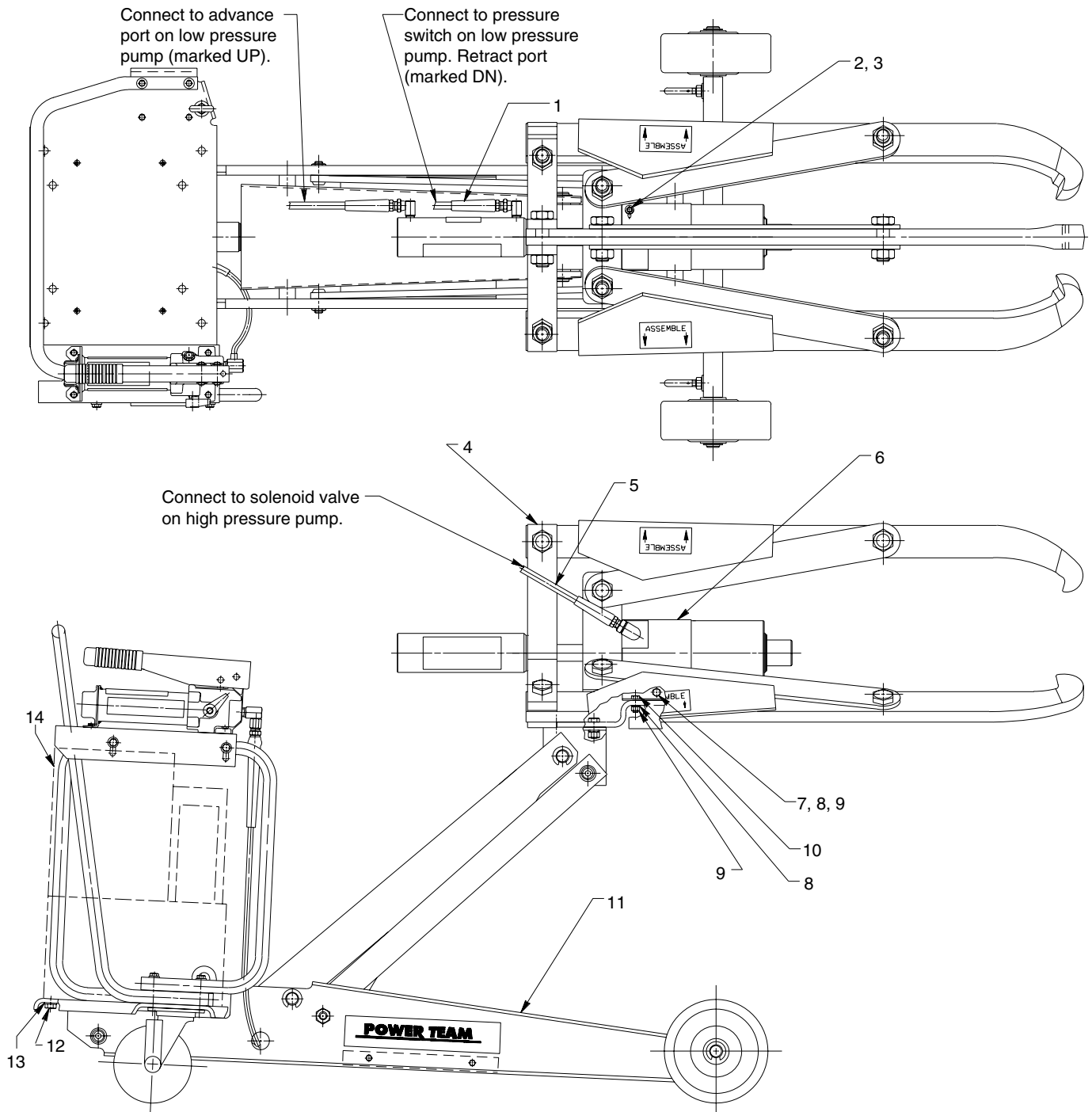

Parts List, Form No. 101307, Back sheet 1 of 9

Item No.	Part No.	No. Req'd	Description
1	350592	2	Hydraulic Hose Assembly
2	10048	1	Cap Screw (3/8-16 UNC x 7/8 Lg.)
3	10258	1	Washer (for 3/8 bolt)
4	64332	1	Puller Assembly (For PH553C & PH553C-230; See sheet 2 of 9)
	64535	1	Puller Assembly (For PH553CL & PH553CL-230; See sheet 2 of 9)
	64389	1	Puller Assembly (For PH553C13 & PH553C13-230; See sheet 2 of 9)
	64533	1	Puller Assembly (For PH553CL13 & PH553CL13-230; See sheet 2 of 9)
5	350655	1	Hydraulic Hose Assembly
6	58336	1	Puller Mounting Bracket
7	251020	1	Cap Screw (3/8-16 UNC x 1-3/4 Lg.)
8	10247	5	Washer (For 3/8 bolt)
9	10204	5	Hex Nut (3/8-16 UNC)
10	10052	4	Cap Screw (3/8-16 UNC x 1-1/4 Lg.)
11	64338	1	55 Ton Enforcer Cart (See Form No. 101319)
12	10076	4	Cap Screw (1/2-20 UNF x 7/8 Lg.)
13	10249	4	Lockwasher (For 1/2 bolt)
14	64335	1	Tandem Electric Hydraulic Pump (For PH553C, PH553CL, PH553C13, & PH553CL13; See back sheet 3 of 9)
	64335-230	1	Tandem Electric Hydraulic Pump (For PH553C-230, PH553CL-230, PH553C13-230, & PH553CL13-230; See back sheet 3 of 9)

PARTS INCLUDED BUT NOT SHOWN

251002	1	End Adapter
350593	2	Adapter
350594	1	Adapter
350637	1	Adapter

Refer to any operating instructions included with this product for detailed information about operation, testing, disassembly, reassembly, and preventive maintenance.

Items found in this parts list have been carefully tested and selected. **Therefore: Use only genuine Power Team replacement parts!**

Additional questions can be directed to our Technical Services Department.

PULLER ASSEMBLY

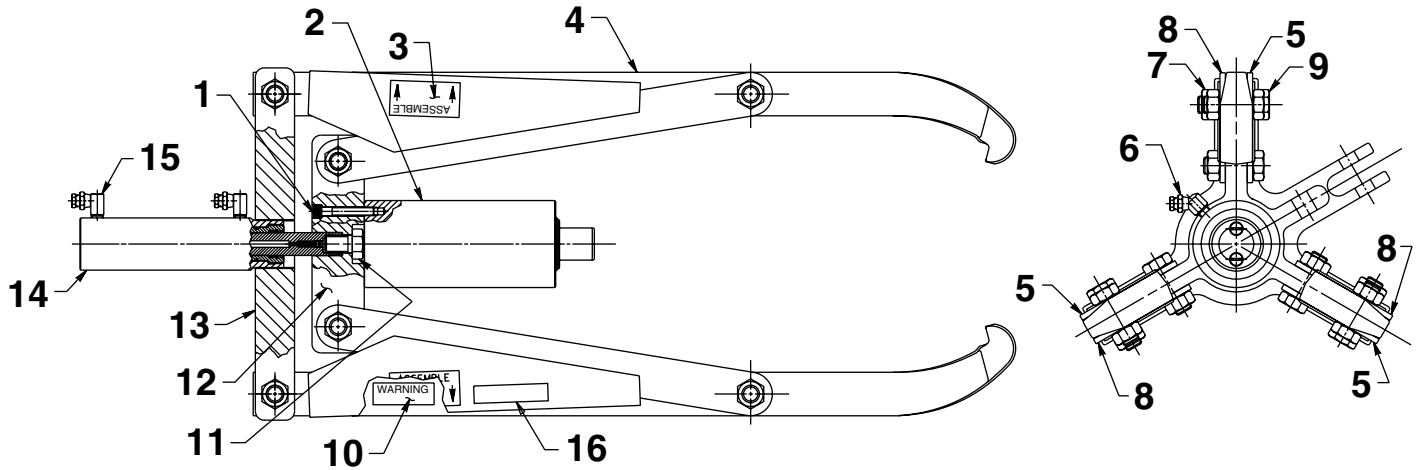

Item No.	Part No.	No. Req'd	Description
1	12046	4	Cap Screw (1/2-13 UNC x 3" Lg.; Apply Loctite No. 222. Torque to 50/70 ft. lbs.)
2	64329	1	Ram Assembly (For PH553C, PH553CL, PH553C-230, PH553CL-230; See sheet 3 of 9)
	64391	1	Ram Assembly (For PH553C13, PH553CL13, PH553C13-230, & PH553CL13-230; See sheet 3 of 9)
3	251058	6	Decal
4	58315	3	Short Jaw (For PH553C, PH553C13, PH553C-230, & PH553CL13-230)
	58462	3	Long Jaw (For PH553CL, PH553CL13, PH553CL-230, & PH553CL13-230)
5	420611GY8	3	Short Strap & Guard Weldment (Left Hand; For PH553C, PH553C13, PH553C-230, & PH553CL13-230)
	420806GY8	3	Long Strap & Guard Weldment (Left Hand; For PH553CL, PH553CL13, PH553CL-230, & PH553CL13-230)
6	10648	1	45° Elbow Fitting
7	250901	9	Locknut (1-8 UNC)
8	420610GY8	3	Short Strap & Guard Weldment (Right Hand; For PH553C, PH553C13, PH553C-230, & PH553CL13-230)
	420805GY8	3	Long Strap & Guard Weldment (Right Hand; For PH553CL, PH553CL13, PH553CL-230, & PH553CL13-230)
6	10648	1	45° Elbow Fitting
9	250905	9	Cap Screw (1-8 UNC x 3-1/2 Lg.)
10	251057	6	Warning Decal
11	15081	1	Cap Screw (#1-8 UNC X 1-1/2 Lg.; Apply Loctite No. 222. Torque to 80/110 ft. lbs.)
12	58317	1	2/3 Way Puller Head
13	64331	1	2/3 Way Puller Head
14	58320	1	Cylinder Assembly (See Form No. 101301)
15	250385	2	90° Elbow Fitting
16	252077	1	Patent Decal

CYLINDER ASSEMBLY

Max. Capacity: 55.2 Ton At 10,000 PSI

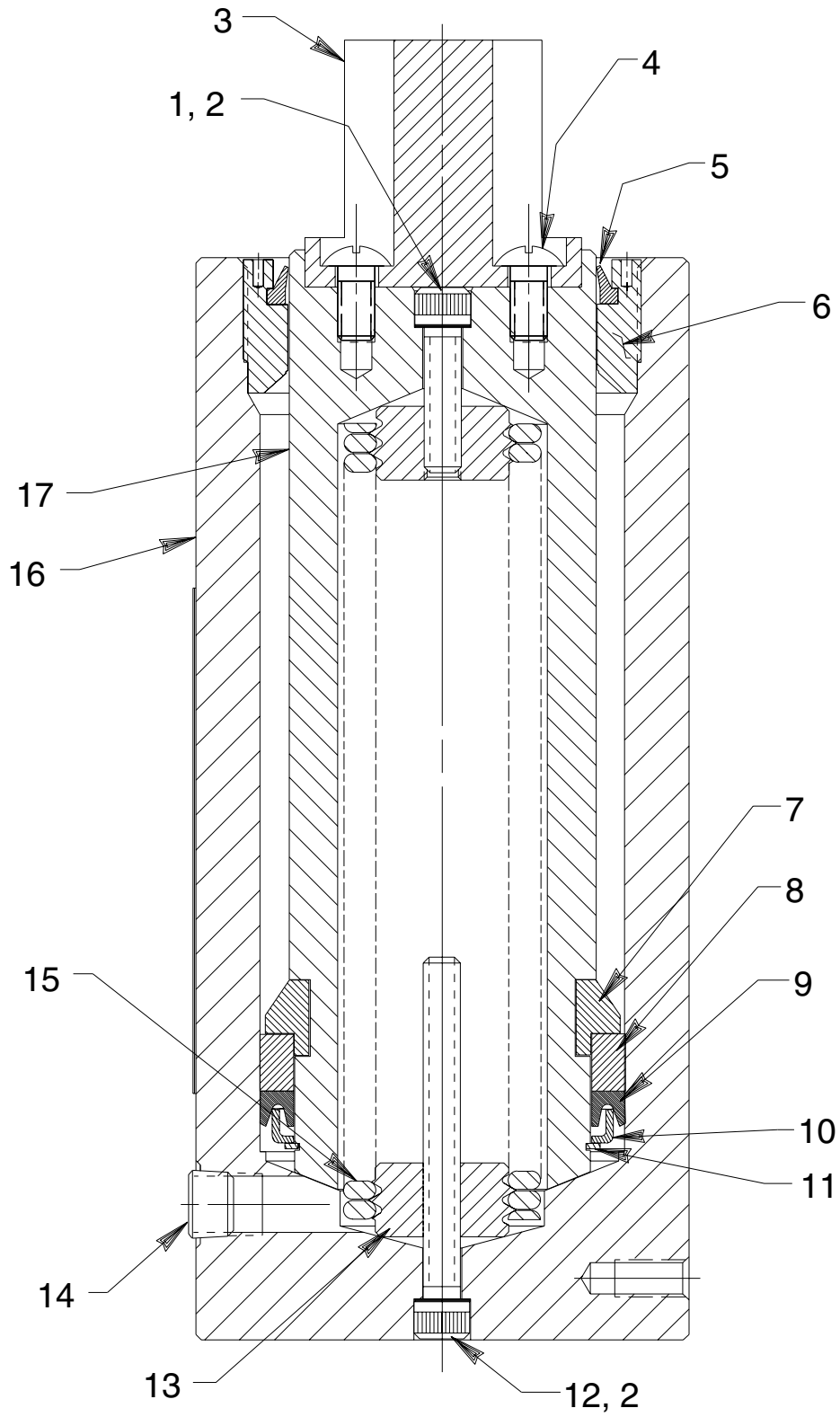

Item No.	Part No.	No. Req'd	Description
1	10984	1	Cap Screw (3/8-16 UNC x 1-1/2 Lg.; Torque to 500/550 in. lbs.)
2	†*12042	2	Copper Washer (9/16 X 3/8 X 1/32)
3	350552	1	Ram Adapter
4	16112	2	Machine Screw (3/8-16 UNC X 3/4 Lg.; Tighten securely)
5	*16117	1	Rod Wiper
	†205718	1	Rod Wiper
6	36138	1	Retainer Nut (Torque to 125/150 ft. lbs.)
7	36001	1	Keeper Ring
8	201481	1	Piston Head
9	*15916	1	U-cup
	†205706	1	U-cup
10	201480	1	Slip Retainer
11	*16118	1	Retaining Ring
12	16110	1	Cap Screw (3/8-16 UNC X 3-1/2 Lg.; Torque to 500/550 in. lbs.)
13	36170	2	Spring Retainer
14	11127	1	Pressure Plug (3/8 NPTF)
15	201483	1	Extension Spring (For PH553C, PH553CL, PH553C-230, & PH553CL-230)
	201484	1	Extension Spring (For PH553C13, PH553CL13, PH553C13-230, & PH553CL13-230)
16	64328	1	Cylinder Body (For PH553C, PH553CL, PH553C-230, & PH553CL-230)
	64390	1	Cylinder Body (For PH553C13, PH553CL13, PH553C13-230, & PH553CL13-230)
17	50837	1	Piston Rod (For PH553C, PH553CL, PH553C-230, & PH553CL-230)
	50836	1	Piston Rod (For PH553C13, PH553CL13, PH553C13-230, & PH553CL13-230)

PARTS INCLUDED BUT NOT SHOWN

*37782	1	Warning Decal
†206557	1	U-cup Backup Washer
†205724	1	Decal (Viton)

Part numbers marked with an asterisk (*) are contained in Repair Kit No. 300114.
 Part numbers marked with a dagger (†) are contained in Repair Kit No. 300215.

SPRING & RETAINER ASSEMBLY

The spring must not extend beyond the threads of the spring retainer on either end. Stretch, clean and lubricate the spring before assembly.

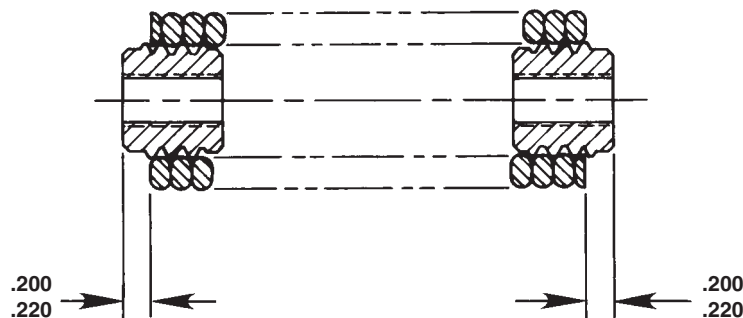

TANDEM ELECTRIC HYDRAULIC PUMP TOP VIEW

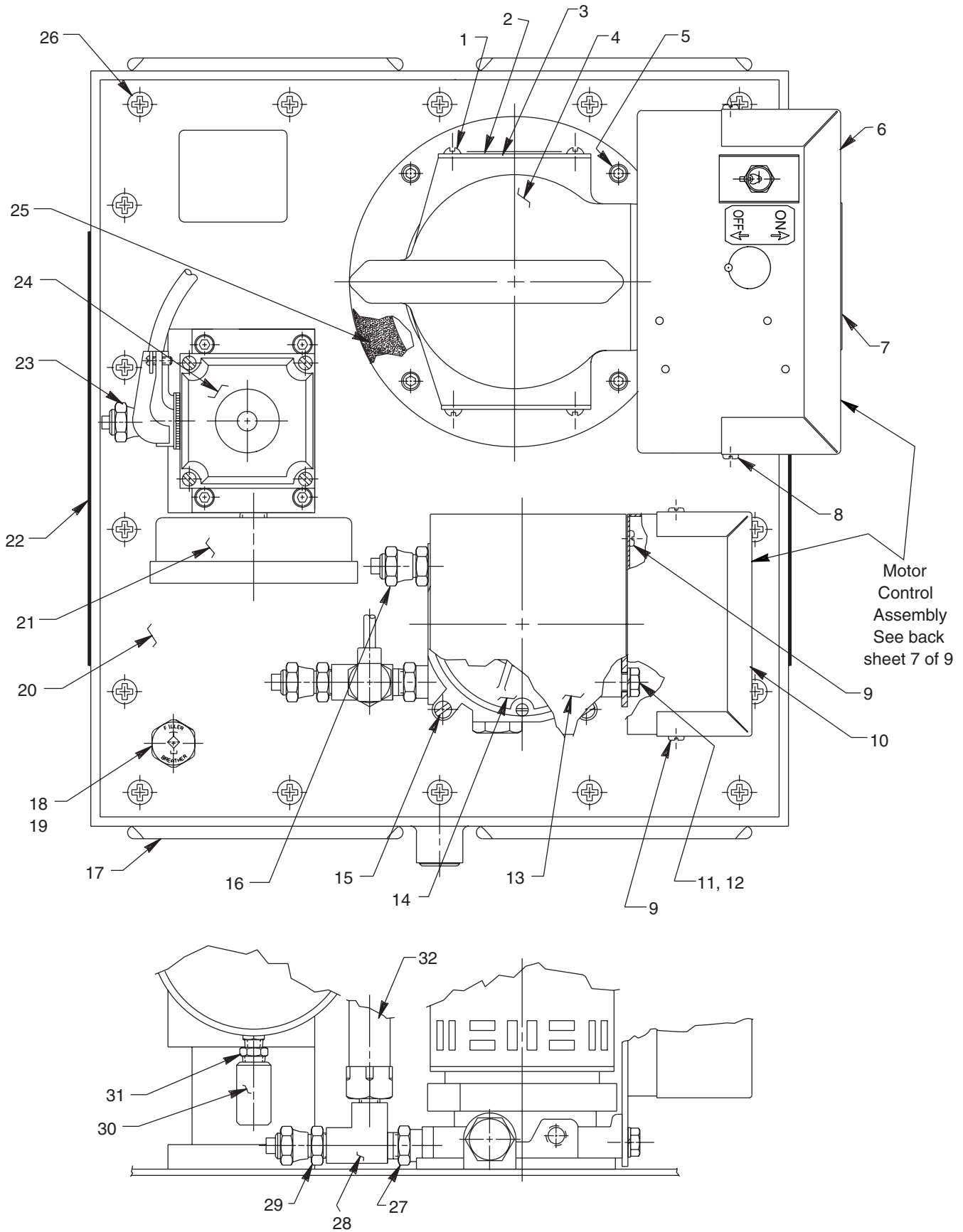

Item No.	Part No.	No. Req'd	Description
1	10164	4	Screw (#10-24 UNC X 3/8 Lg.)
2	215164	1	Specifications Decal (For PH553C, PH553CL, PH553C13, & PH553CL13)
	215163	1	Specifications Decal (For PH553C-230, PH553CL-230, PH553C13-230, & PH553CL13-230)
3	21008	2	Cover
4	53338	1	Motor (For PH553C, PH553CL, PH553C13, & PH553CL13)
	53337	1	Motor (For PH553C-230, PH553CL-230, PH553C13-230, & PH553CL13-230)
5	10022	4	Screw (1/4-20 UNC X 1-1/2 Lg.)
6	43126WH2	1	Cover
7	200188	1	Warning Decal
8	14812	4	Tap Screw (#8-18 X 3/8 Lg.)
9	11141	6	Tap Screw (#6-20 X 3/8 Lg.)
10	42576WH2	1	Electrical Box Cover
11	12368	2	Cap Screw (3/8-16 UNC X 1/2 Lg.)
12	10247	2	Washer (For 3/8 bolt)
13	350624WH2	1	Motor Cover
14	420548	1	Electric/Hydraulic Pump Assembly (115 V. - For PH553C, PH553CL, PH553C13, & PH553CL13; For parts and service information on this pump, contact Power Team Technical Services.)
	420798	1	Electric/Hydraulic Pump Assembly (230 V. - For PH553C-230, PH553CL-230, PH553C13-230, & PH553CL13-230; For parts and service information on this pump, contact Power Team Technical Services.)
15	10429	4	Machine Screw (8-32 UNC x 1/2 Lg.)
16	250690	1	Straight Fitting
17	60234OR9	1	Reservoir
18	20937	1	Vent Cap
19	200415	1	Rubber Gasket
20	64373WH2	1	Cover Plate
21	9069	1	Gauge
22	309219	2	Decal
23	9675	1	Adapter Union
24	42621	1	Solenoid Valve (For PH553C, PH553CL, PH553C13, & PH553CL13 - See Form No. 100445)
	44084	1	Solenoid Valve (For PH553C-230, PH553CL-230, PH553C13-230, & PH553CL13-230; See Form No. 100445)
25	30650	1	Gasket
26	16876	18	Screw (10-24 UNC X 1/2 Lg.)
27	210312	1	Straight Fitting
28	10618	1	Service Tee
29	11310	1	Adapter Union
30	10617	1	Elbow
31	13269	1	Reducer Bushing
32	251074	1	Pressure Switch

BOTTOM VIEW

Basic Pump
Assembly
See sheet 5 of 9

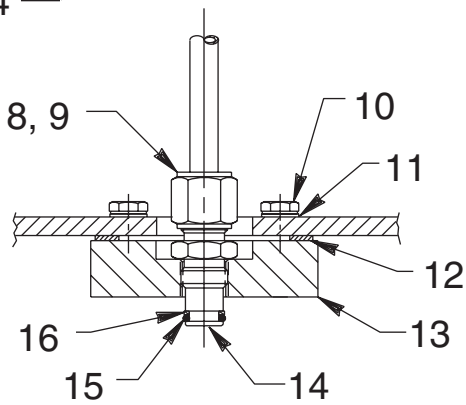
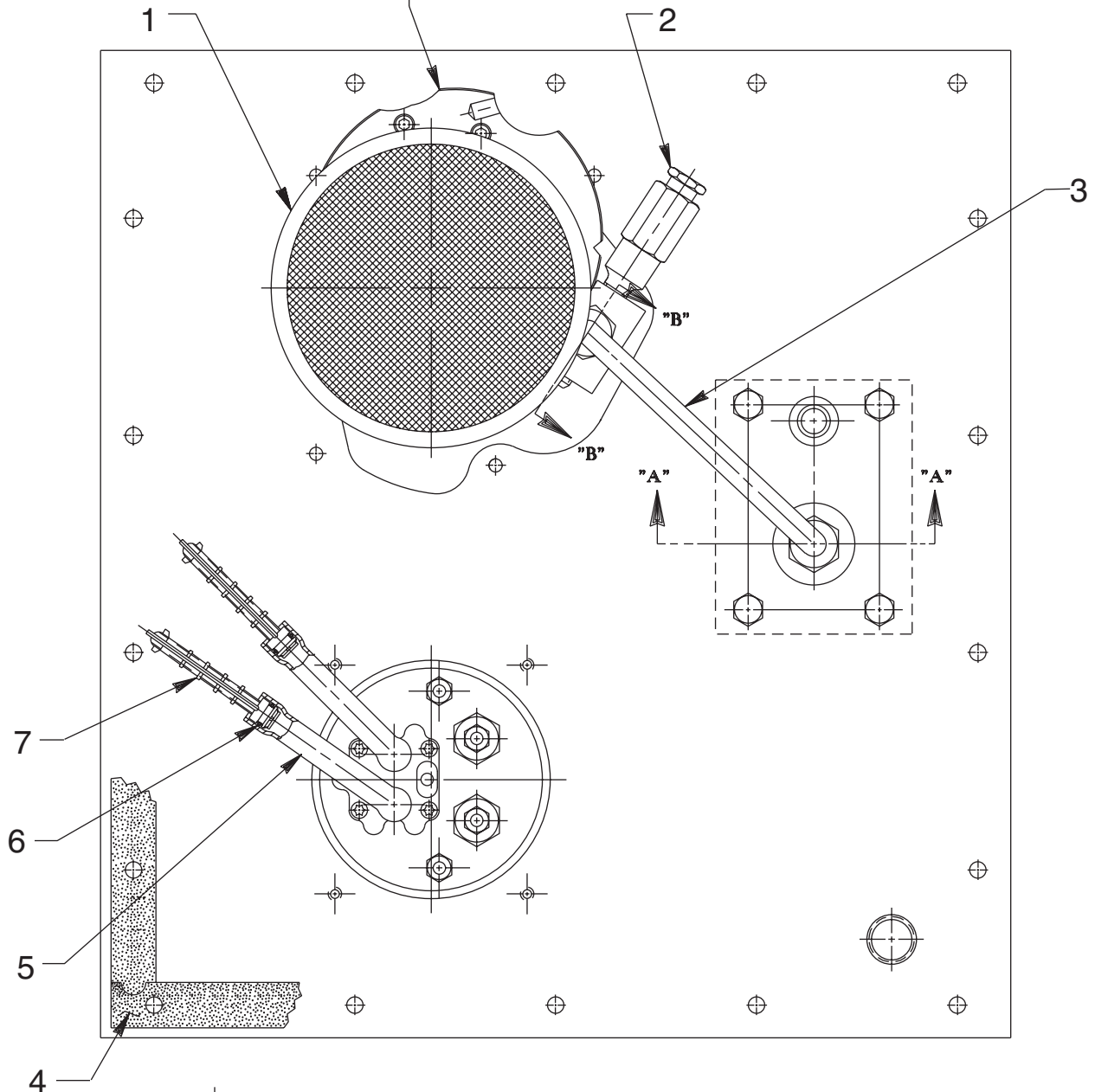

SECTION A - A

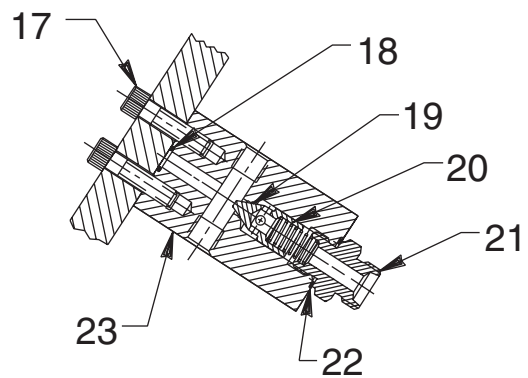

SECTION B - B

Item No.	Part No.	No. Req'd	Description
1	21344	1	Filter Assembly
2	21278	1	Relief Valve Assembly (Set at 10,100/10,700 PSI)
3	350635	1	Oil Line Tube
4	50712	1	Gasket
5	15028	.66 ft.	Clear Plastic Tubing
6	12557	2	O-ring (11/32 X 7/32 X 1/16)
7	215075	2	Filter
8	10430	2	Tube Sleeve
9	10431	2	Tube Nut
10	10005	4	Cap Screw (1/4-20 UNC X 1/2 Lg.)
11	10244	4	Lockwasher (For 1/4 bolt)
12	200395	1	Gasket
13	43110	1	Mounting Block
14	20787	1	Valve Connector
15	10268	1	O-ring (1/2 X 3/8 X 1/16)
16	11863	1	Backup Washer (1/2 X 3/8 X 1/16)
17	10015	2	Cap Screw (1/4-28 UNF X 1" Lg.)
18	10266	2	O-ring (3/8 X 1/4 X 1/16)
19	20771	1	Poppet
20	10425	1	Compression Spring (3/8 O.D. X 3/4 Lg.)
21	20770	1	Connector (Torque to 40/45 ft. lbs. oiled.)
22	10261	1	Washer (3/4 X 19/32 X 1/32)
23	20776	1	Valve Body

BASIC PUMP ASSEMBLY

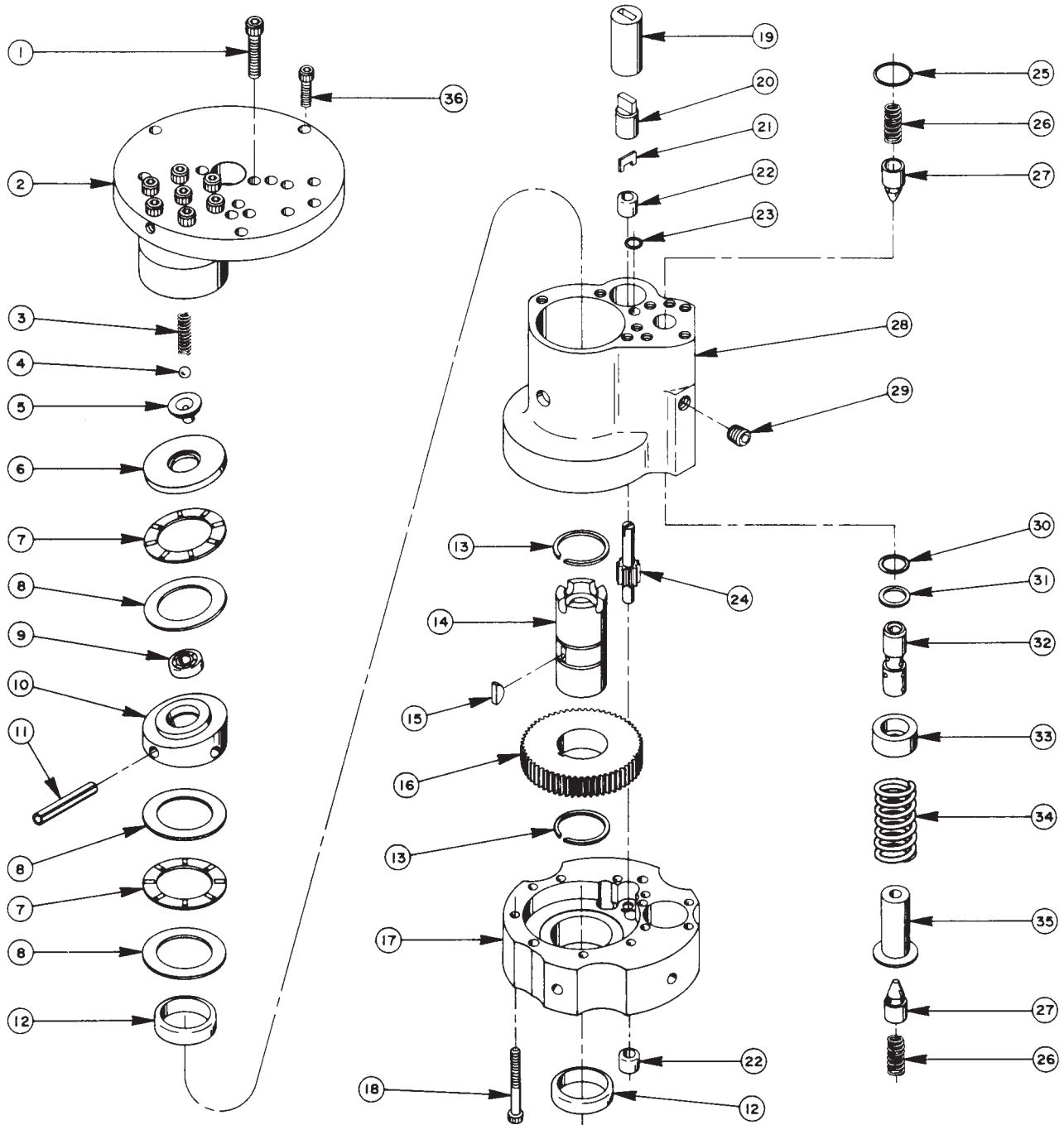

Item No.	Part No.	No. Req'd	Description
1	10020	9	Soc. Hd. Cap Screw (1/4-20 UNC X 1-1/4 Lg.; Torque to 170-180 in. lbs.)
2	33113	1	High Pressure Pump Ass'y (See back sheet 6 of 9)
3	10361	1	Compression Spring (1/4 O.D. X 1" Lg.)
4	10375	1	Steel Ball (1/4" dia.)
5	23547	1	Bearing Top Plate
6	23548	1	Top Plate
7	11228	2	Thrust Bearing
8	11813	3	Bearing Race
9	11814	1	Ball Bearing
10	23549	1	Angle Plate
11	11955	1	Roll Pin (1/4" dia. X 1-3/4 Lg.)
12	11064	2	Needle Bearing
13	11261	2	Retaining Ring
14	23556	1	Shaft
15	11821	1	Woodruff Key
16	23574	1	Gear
17	40072	1	Pump End Plate
18	10001	13	Soc. Hd. Cap Screw (#10-32 UNF X 1-3/4" Lg.; Torque to 50 in. lbs.)
19	21091	1	Zinc Coupling
20	21092	1	Adapter
21	21093	1	Key
22	11198	2	Needle Thrust Bearing (See Note below)
23	10266	1	O-ring (3/8 X 1/4 X 1/16)
24	20774	1	Drive Gear
25	10303	1	O-ring (7/8 X 3/4 X 1/16)
26	10425	2	Compression Spring (3/8 O.D. X 3/4 Lg.)
27	20771	2	Poppet
28	40071	1	Pump Body
29	10427	1	Pipe Plug (1/8" NPTF)
30	10271	1	O-ring (11/16 X 1/2 X 3/32)
31	12389	1	Teflon Backup Washer (11/16 X 1/2 X 1/16)
32	20849	1	Spool
33	23255	1	Spring Guide
34	10426	1	Compression Spring (1" O.D. X 1-13/16 Lg.)
35	23256	1	Spring Guide
36	10016	3	Cap Screw (1/4-20 UNC X 1" Lg.)

NEEDLE BEARING INSTALLATION SPECIFICATIONS

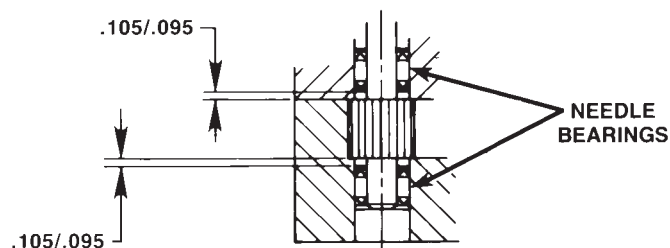

When replacing the needle bearings on the drive gear of the basic pumps, the dimensions shown must be as specified.

Sheet No. 6 of 9

Rev. 8 Date: 16 June 2000

HIGH PRESSURE PUMP ASSEMBLY

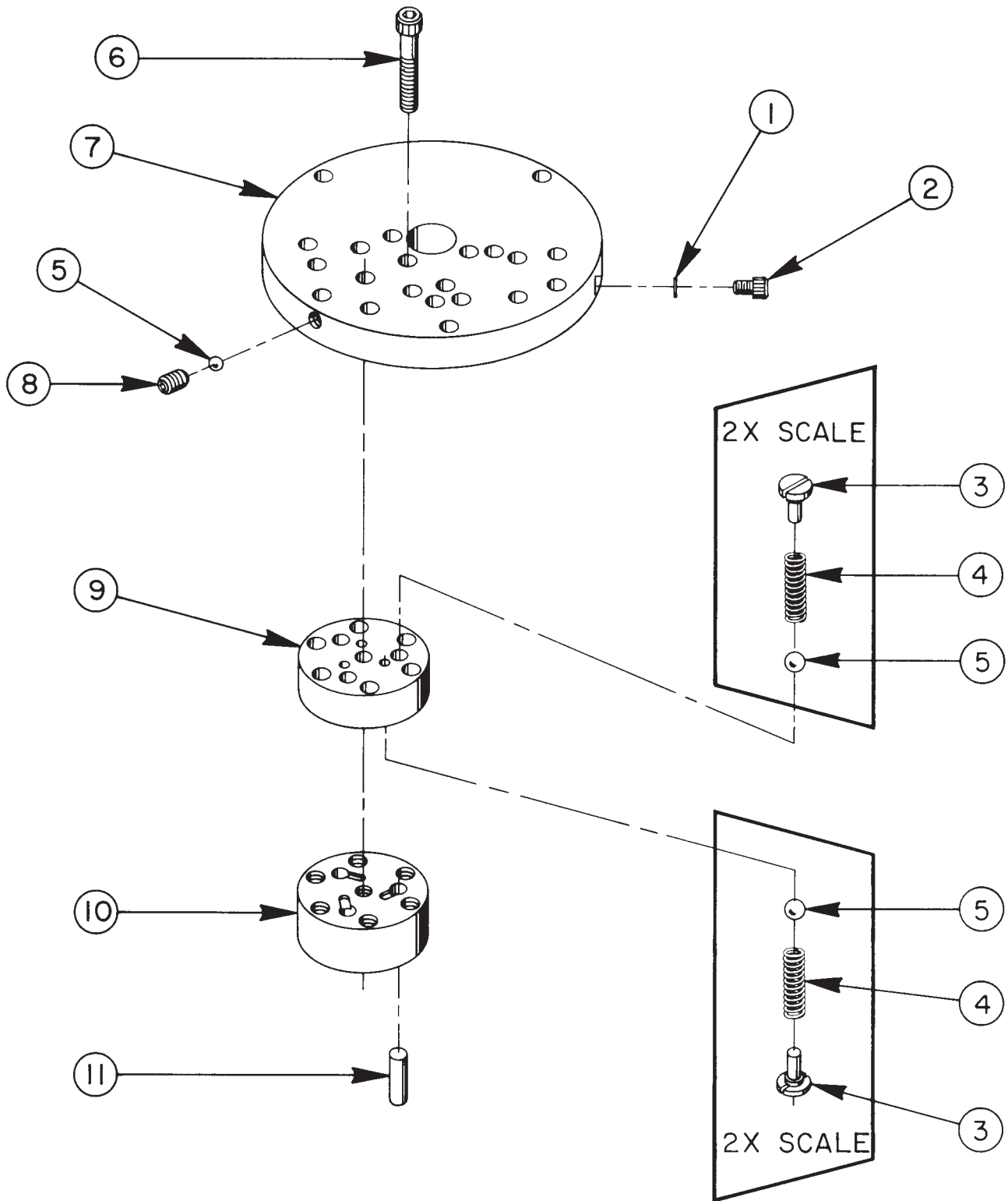

33113 PUMP ASSEMBLY

3 Pistons -- 9/32 Dia.

Item No.	Part No.	No. Req'd	Description
1	10442	1	Copper Washer (3/8 X 1/4 X 1/32)
2	10002	1	Soc. Hd. Cap Screw (1/4-20 UNC X 3/8" Lg.; Torque to 140/160 in. lbs.)
3	24549	6	Valve Guide
4	10445	6	Compression Spring (5/32" O.D. X 3/4" Lg.)
5	12223	7	Steel Ball
6	10023	7	Soc. Hd. Cap Screw (1/4-20 UNF X 1-1/2" Lg.; Torque to 170/180 in. lbs.; See note below)
7	50411	1	Top Plate
8	10519	1	Soc. Set Screw (1/4-20 UNC X 3/8 Lg.; Torque to 65/70 in. lbs.)
9	40630	1	Valve Head
10	41062	1	Pump Barrel
11	21628	3	Piston

BOLT TIGHTENING SEQUENCE

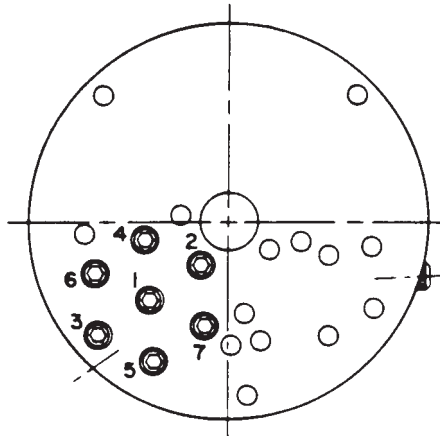

**NOTE: Assemble in sequence shown.
Lubricate under head and on
threads. Torque to 180 in. lbs.**

MOTOR CONTROL ASSEMBLY

115 V., 50/60 Hz. -- For PH553C, PH553C13, PH553CL, & PH553CL13

and

220/230 V., 50/60 Hz. -- For PH553C-230, PH553C13-230, PH553CL-230, & PH553CL13-230

POWER CORD GROUND
(Must be isolated between nuts and can be at top or bottom of stack.)

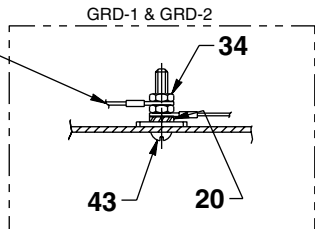

NOTE: SERRATED LOCK WASHER MUST BE ADJACENT TO METAL BOX. MORE WASHERS CAN BE USED IF DESIRED.

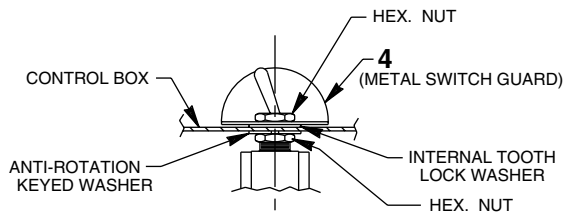
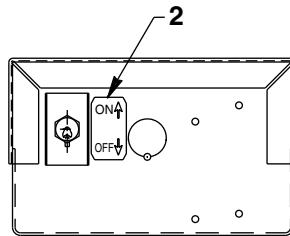
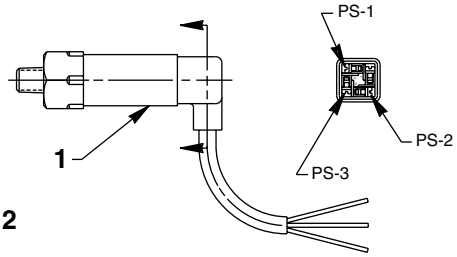

SWITCH DETAIL

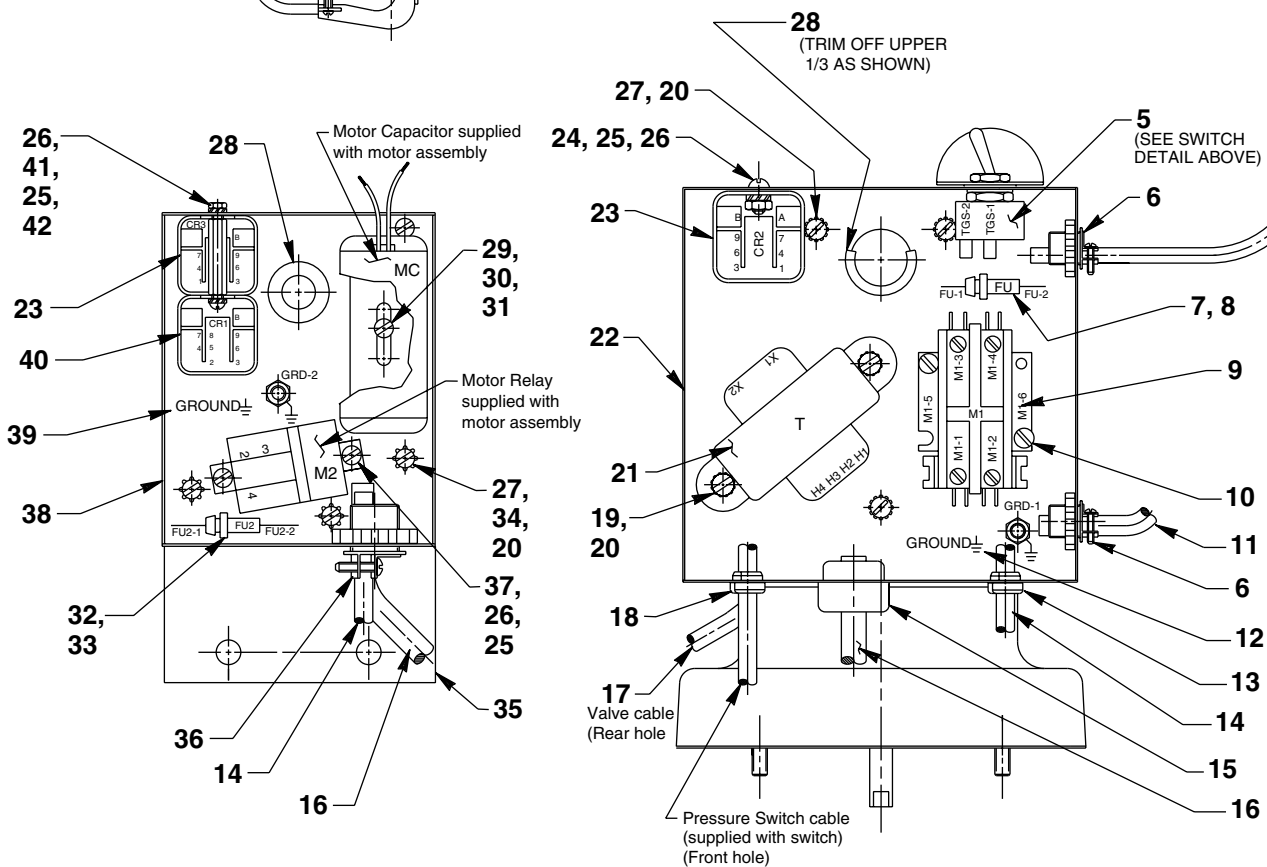
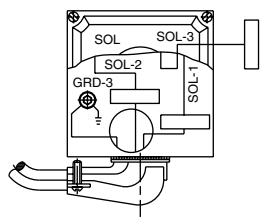

Item No.	Part No.	No. Req'd	Description
1	251074-1	1	Pressure Switch
2	205490	1	Decal (Run-Jog)
3	351597	1	Hand Switch Assembly (See sheet 9 of 9)
4	352061	1	Switch Guard
5	12301	1	Toggle Switch
6	11203	2	Conduit Connector
7	16887	2	Fuse Holder
8	206962	1	Fuse (3 AMP, 250 V.)
9	420718-4	1	Contactor (2-pole)
10	10166	2	Machine Screw (#10-24 UNC X 1/2 Lg.)
11	307440	1	Cord Set (For PH553C, PH553C13, PH553CL, & PH553CL13)
	308752	8 ft.	Cable (14/3 SJTO; For PH553C-230, PH553CL-230, PH553C13-230, & PH553CL13-230)
12	205189	2	Ground Decal
13	15993	2	Strain Relief Bushing
14	12908	2.33 ft.	Cable
15	210112	1	Strain Relief Bushing
16	13336	2.33 ft.	Electric Cable
17	12293	28"	Cable (16/3 SJTO; For valve)
18	215857	1	Strain Relief Bushing
19	11539	2	Machine Screw (#10-24 X 1/4 Lg.)
20	11108	9	Lockwasher (#10 External Tooth)
21	11852	1	Transformer
22	51218WH2	1	Electrical Control Box
23	39092	2	Relay
24	10159	2	Machine Screw (#6-32 UNC X 5/16 Lg.)
25	15906	8	Lockwasher (#6 External Tooth)
26	10195	4	Nut (#6-32 UNC)
27	10164	6	Slotted Screw (#10-24 UNC X 3/8 Lg.)
28	15497	2	Grommet
29	10962	1	Machine Screw (8-32 UNC X 1/2 Lg.)
30	17644	1	Lockwasher (For No. 8 bolt)
31	10196	1	Hex Nut (#8-32 UNC)
32	16887	1	Fuse Holder
33	250176	1	Fuse
34	10197	3	Hex Nut (10-24)
35	350585	1	Mounting Bracket
36	211240	1	Connector
37	11426	2	Machine Screw (6-32 UNC x 1/2 Lg.)
38	45013WH2	1	Electrical Box
39	205189	1	Ground Decal
40	305602	1	Relay
41	17563	2	Machine Screw (6-32 UNC X 1/4 Lg.)
42	215376	2	Stand Off
43	11856	1	Machine Screw (#10-24 X 1" Lg.)

ELECTRICAL SCHEMATIC - 115 V., 50/60 Hz. For PH53C, PH55CL13, PH553CL, & PH553CL13

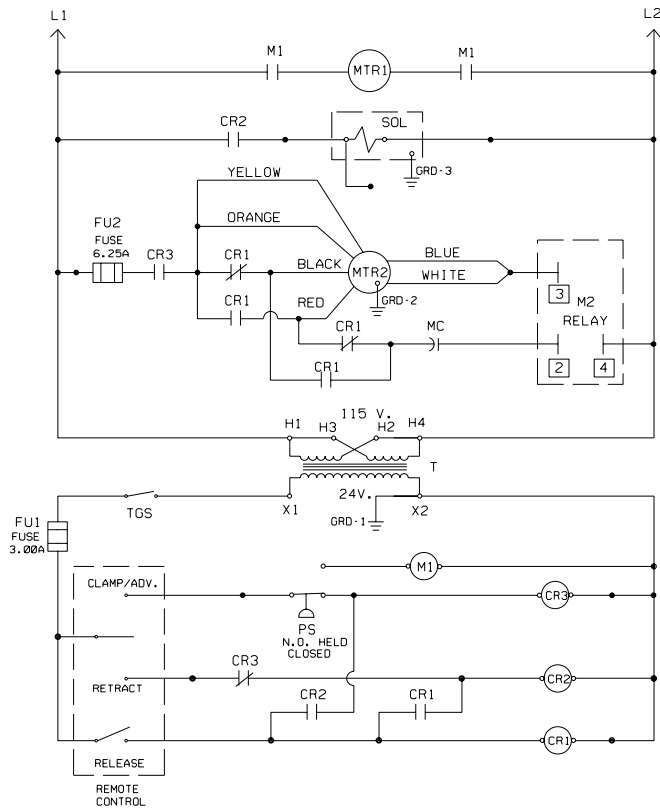

WARNING

To help avoid personal injury, all electrical work must be done by a qualified electrician.

North American & International Color Codes

Conductors	North American	International
Line	Black	Brown
Neutral	White	Blue
Ground	Green	Green/Yellow

ELECTRICAL SCHEMATIC - 220/230 V., 50/60 Hz. For PH53C-230, PH55CL13-230, PH553CL-230, & PH553CL13-230

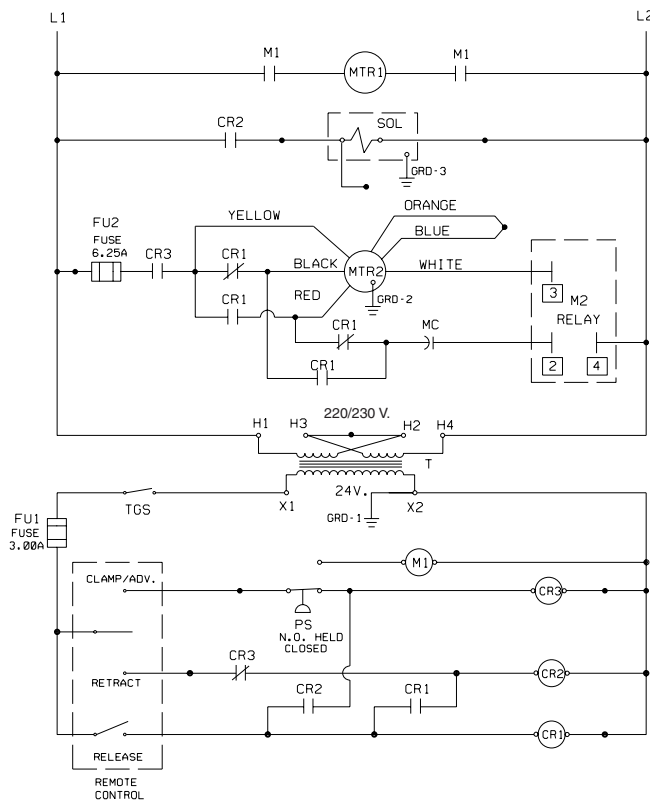

WARNING

To help avoid personal injury, all electrical work must be done by a qualified electrician.

North American & International Color Codes

Conductors	North American	International
Line	Black	Brown
Neutral	White	Blue
Ground	Green	Green/Yellow

REMOTE HAND CONTROL ASSEMBLY

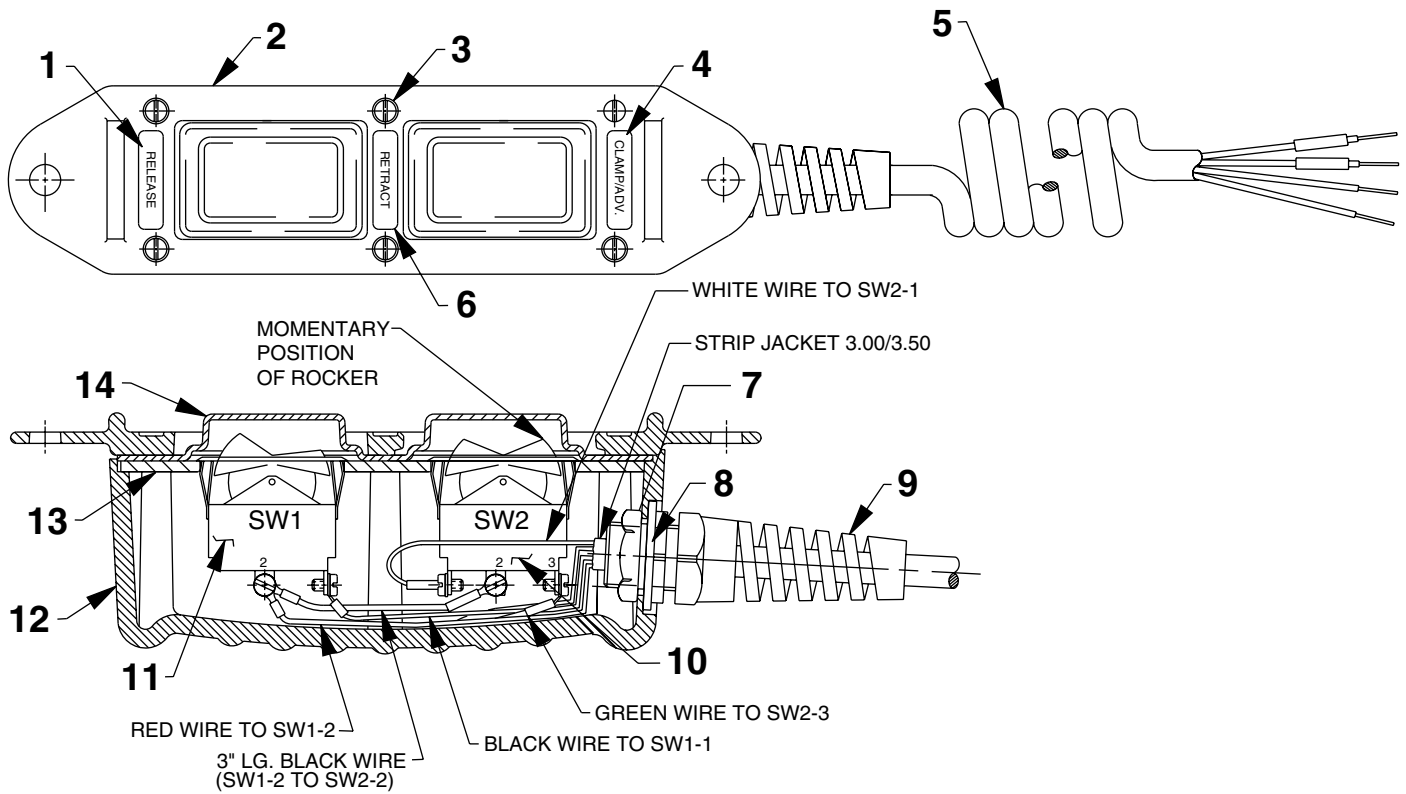

Item No.	Part No.	No. Req'd	Description
1	251071	1	Decal (Release)
2	251044	1	Cover
3	250248	6	Screw (4-24 x 3/4 Lg.)
4	251070	1	Decal (Clamp / Advance)
5	350642	1	Cable (coiled)
6	29664	1	Decal (Retract)
7	251802	1	Locknut
8	253607	1	Rubber Gasket
9	251818	1	Strain Relief Connector
10	16774	1	Rocker Switch (Prior to 9-1-97)
	16773	1	Rocker Switch (After 9-1-97)
11	16772	1	Rocker Switch
12	420050-4	1	Switch Housing
13	420050-3	1	Switch Mounting Plate
14	420050-2	1	Gasket