

Heber mit Stellring 20 bis 60 Tonnen

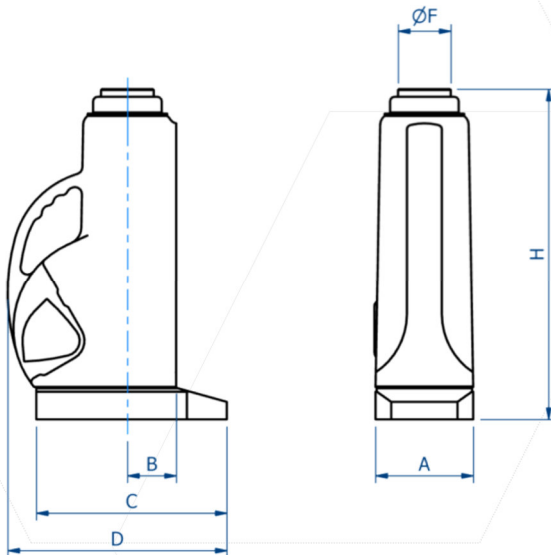

v



| Typ | PS1220S | PS1230S | PS1260S |
|-----------------------|---------|---------|---------|
| Hubkraft in Tonnen | 20 | 30 | 60 |
| Gewicht in kg | 16,7 | 23,4 | 43,7 |
| Arbeitsdruck in bar | 682 | 644 | 644 |
| Ölmenge in l | 1,14 | 1,71 | 2,84 |
| Dimensionen | mm | mm | mm |
| A - Breite | 121 | 140 | 190 |
| B - Mitte bis Flanke | 60 | 70 | 92 |
| C - Sockellänge | 246 | 273 | 339 |
| D - Tiefe | 289 | 311 | 384 |
| F - Durchmesser | 60 | 76 | 108 |
| H - Höhe, eingefahren | 464 | 479 | 536 |
| Hub | 305 | 305 | 305 |

