

Heber mit Stellring 20 bis 100 Tonnen

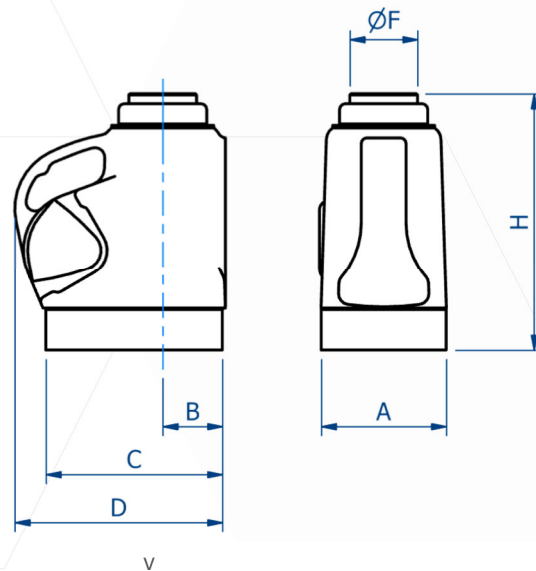

Typ	PS620S	PS630S	PS660S	P6100S
Hubkraft in Tonnen	20	30	60	100
Gewicht in kg	10,9	15,4	27,4	53
Arbeitsdruck in bar	682	644	644	640
Ölmenge in l	0,64	0,88	1,71	2,3
Dimensionen	mm	mm	mm	mm
A - Breite	121	140	190	241
B - Mitte bis Flanke	60	70	92	124
C - Sockellänge	178	197	251	310
D - Tiefe	214	235	286	310
F - Durchmesser	60	76	108	140
H - Höhe, eingefahren	289	292	330	357
Hub	152	152	152	152

