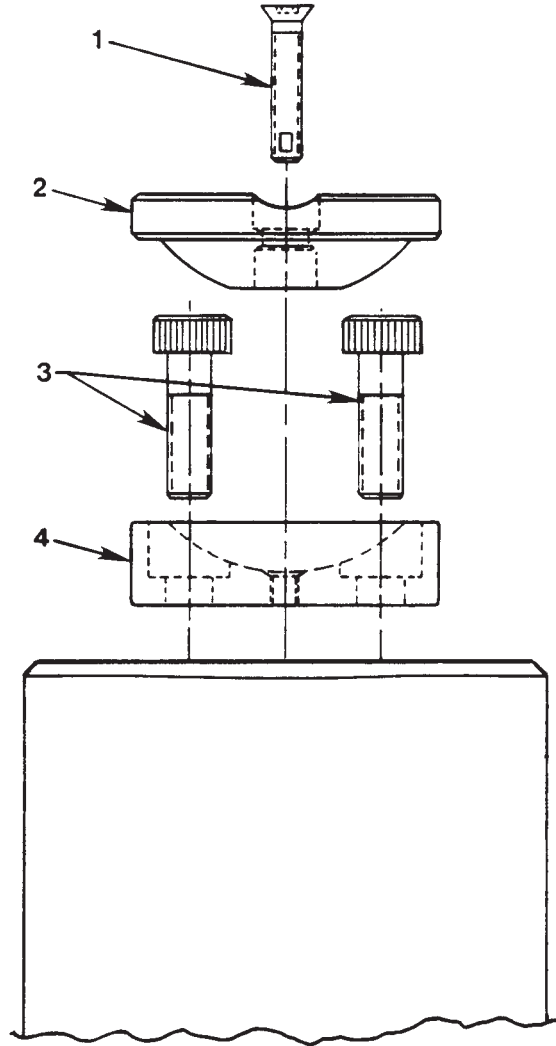

**TILT SADDLE CAP ASSEMBLY  
FOR C-SERIES 100 TON CYLINDERS**

Item No.	Part No.	No. Req'd	Description
1	250648	1	Hex. Soc. Flat Hd. Screw
2	420370	1	Swivel Cap
3	10464	2	Soc. Hd. Cap Screw (3/8-16 UNC x 3/4 Lg.; Torque to 320/340 in. lbs.)
4	421606	1	Tilt Saddle Base

## **ASSEMBLY INSTRUCTIONS**

1. Mount tilt saddle base to cylinder piston with appropriate socket head cap screws (Item 3). Torque as specified.
2. Position swivel cap on base and tilt until lip on swivel cap contacts the base.
3. Thread in self-locking flat head screw. DO NOT overtighten. Swivel cap should swivel freely, and lip on swivel cap should always contact the base at maximum tilt angle.