

TILT SADDLE CAP ASSEMBLY
FOR 55 TON "C" & "RA" SERIES CYLINDERS

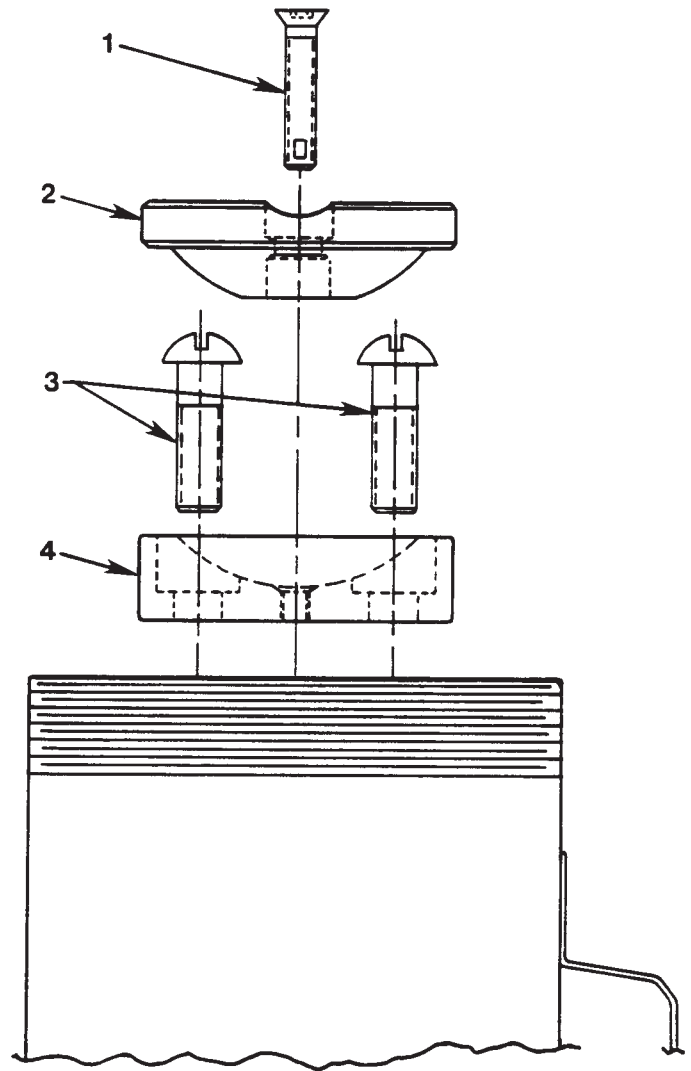

Item No.	Part No.	No. Req'd	Description
1	215757	1	Hex. Soc. Hd. Screw
2	350252	1	Swivel Cap
3	16112	2	Rd. Hd. Machine Screw
4	350254	1	Tilt Saddle Base

ASSEMBLY

1. Mount tilt saddle base to cylinder piston with two round head machine screws.
2. Position swivel cap on base and tilt until lip on swivel cap contacts the base.
3. Thread in self-locking flat head screw. **DO NOT** overtighten. Swivel cap should swivel freely, and lip on swivel cap should always contact the base at maximum tilt angle.

Note: Shaded areas reflect last revision(s) made to this form.