



SPX Corporation
5885 11th Street
Rockford, IL 61109-3699 USA

Tech. Services: (800) 477-8326
Fax: (800) 765-8326
Order Entry: (800) 541-1418
Fax: (800) 288-7031

Internet Address:
<http://www.powerteam.com>

Operating Instructions for:

PE102	PE102A-220-FE	PE104-220
PE102A	PE102A-AERO	PR102
PE102-28-DC	PE102A-COR	PR102-AMP
PE102-28-220DC	PE102A-EMP	P2102-ANCHOR
PE102-28-FSC	PE102A-ETT	PR102A
PE102-220	PE102AR	PR102A-FE
PE102-ANCHOR	PE102AR-220	PR104
PE102A-220	PE104	PR102-HURST-EPR

ELECTRIC HYDRAULIC PUMP

Max. Capacity: 10,000 PSI

NOTE:

- Inspect the pump upon arrival.
- Read and carefully follow these instructions. Most problems with new equipment are caused by improper operation or installation.

NOTE: These instructions cover several standard pumps. Some special units may appear different or have different specifications. Direct any questions to an appropriate Authorized Hydraulic Service Center or our Technical Services Department.

SAFETY PRECAUTION



WARNING

- All WARNING statements must be carefully observed to prevent personal injury.

General Operation

- Before operation the pump, all hose connections must be tightened with proper tools. Do not overtighten. Connections need only be tightened securely and leak-free. Overtightening may cause premature thread failure or may cause high pressure fittings to split at pressures lower than their rated capacities.
- Should a hydraulic hose ever rupture, burst, or need to be disconnected, immediately shut off the pump and shift the control valve twice to release all pressure. Never attempt to grasp a leaking hose under pressure with your hands. The force of escaping hydraulic fluid could cause serious injury.
- Do not subject the hose to potential hazard such as fire, extreme heat or cold, sharp surfaces, or heavy impact. Do not allow the hose to kink, twist, curl, or bend so tightly that the oil flow within the hose is blocked or reduced. Periodically inspect the hose for wear because any of these conditions can damage the hose and possibly result in personal injury.
- Do not use the hose to move attached equipment. Stress may damage the hose and possibly cause personal injury.
- Hose material and coupler seals must be compatible with the hydraulic fluid used. Hoses also must not come in contact with corrosive materials such as creosote-impregnated objects and some paints. Consult the manufacturer before painting a hose. Never paint the couplers. Hose deterioration due to corrosive materials may result in personal injury.

Sheet No. 1 of 3

Rev 5 Date: 21 April 2005

Safety Precautions (Continued)

Pump

- Do not exceed the PSI hydraulic pressure rating noted on the pump name plate or tamper with the internal high pressure relief valve. Creating pressure beyond rated capacities may result in personal injury.
- Before replenishing the oil level, retract the system to prevent overfilling the pump bladder. An overfill may cause personal injury due to excess bladder pressure created when cylinders are retracted.

Cylinder

- Do not exceed rated capacities of the cylinders. Excess pressure may result in personal injury.
- Do not set poorly-balanced or off-center loads on a cylinder. The load may tip and cause personal injury.

Electrical Supply

- Do not use an ungrounded (two-prong) extension cord (except for 12 VDC).
- Avoid conditions which could create an electrical hazard.
- If the power cord is damaged or wiring exposed, replace or repair immediately.

SET-UP AND OPERATION

Electric Motor



WARNING To help avoid possible personal injury,

- Any electrical work must be done by a qualified electrician.
- Disconnect the power supply before removing the motor casing cover or performing repairs or maintenance.

Voltages

Motor voltages are not changeable. They are:

12 VDC	-	11-14 VDC
120 VAC	-	90-130 VAC 50/60 Hz
220 VAC	-	190-240 VAC 50/60 Hz

Hydraulic Set-up

1. Clean the areas around the oil ports of the pump and hydraulic cylinders.
2. Inspect the threads and fittings for signs of wear or damage and replace as needed. Clean all hose ends, couplers, and union ends.
3. Remove the thread protectors from the hydraulic outlets. Connect the hose assembly to the valve and couple the hose to the cylinder.
4. Seal all pipe connections with a high quality pipe thread sealant. Teflon tape can be used to seal hydraulic connections provided only one layer of tape is used. Apply the tape carefully, two threads back, to prevent it from being pinched by the coupler and broken off inside the pipe end. Any loose pieces of tape could travel through the system and obstruct the flow of oil or cause jamming of precision-fit parts.

Filling the Bladder

1. Thoroughly clean the area around the filler cap with a clean cloth to prevent contamination of the oil by foreign particles.
2. Retract all cylinders.
3. Remove the filler cap and insert a clean funnel with filter. Bladder must be filled to the top of filler. All air must be out of bladder.
4. Replace filler cap. **IMPORTANT: Tighten filler cap 1/2 - 1 turn after o-ring contacts sealing surface. Overtightening can cause pump damage.**

Valve Operation

2-Position, 2-Way Manual Valves used with Single-acting Cylinders

1. To build pressure, turn the valve control handle counterclockwise (CCW).
2. Start the pump by pressing the motor control ON/OFF switch.
NOTE: Oil advances the cylinder when the unit is activated.
3. When the cylinder has advanced to the desired position, release the motor control ON/OFF switch.
4. To retract the cylinder, turn the valve control clockwise (CW).

NOTE: The valve works the same as the manifold if the pump is operated with the valve in the RETURN position. In this position, the cylinder advances when the pump is running and retracts when the motor is stopped.

When the valve is in the HOLD position, the cylinder advances when the pump is running and holds when the motor is stopped. The cylinder can be retracted, with the pump off, by moving the valve to the RETURN position.

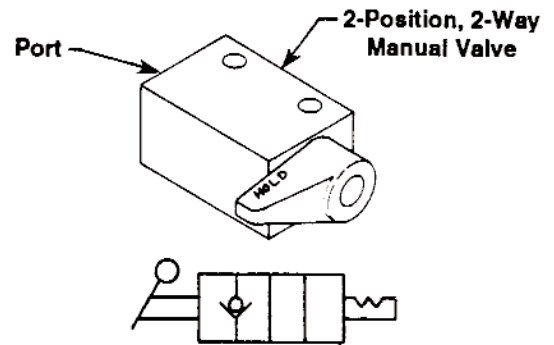

Manifold Assembly used with Single-acting Cylinders or Remote Valves

1. Start the pump by pressing the motor control ON/OFF switch.
NOTE: Oil advances the cylinder when the unit is activated.
2. When the cylinder has advanced to the desired position, release the motor control ON/OFF switch. The cylinder will retract.

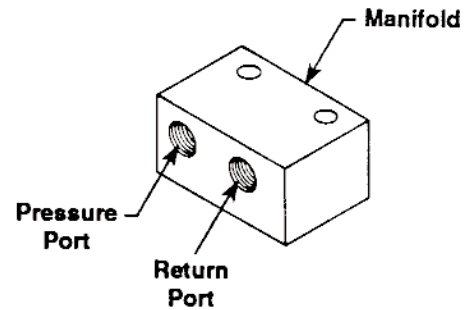

Tandem Center 4-Way Control Valve used with Double-acting Cylinders

1. Place the valve control lever in the NEUTRAL or hold position.
2. Start the pump by pressing the motor control ON/OFF switch.
3. Advance the cylinder by shifting the valve control lever to the ADVANCE position.
4. When the cylinder has advanced to the desired position, release the motor control ON/OFF switch. Cylinder will hold pressure.

NOTE: The cylinder momentarily loses pressure during the transition between valve positions.

5. Retract the cylinder by shifting the valve control lever to the RETRACT position and pressing the motor control ON/OFF switch. Cylinder will retract as long as switch is held.

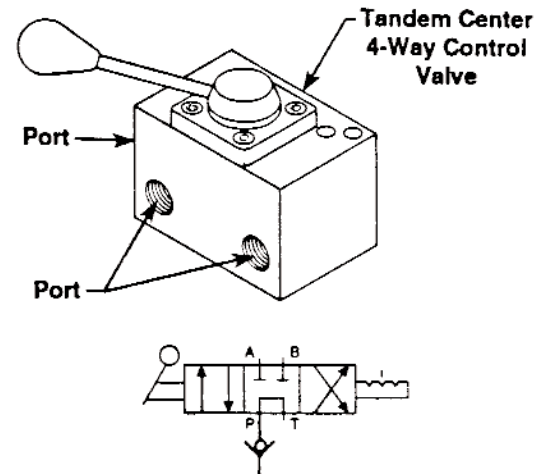

Pressure Regulator

A pressure regulator can be adjusted to bypass oil at a desired pressure setting while the pump motor continues to run.

IMPORTANT: For easy adjustment of the pressure regulator, always adjust the pressure by INCREASING it to a desired pressure setting. The pressure range for these pumps is from 1,000 PSI to 10,000 PSI.

1. Loosen the regulator locking nut, and turn the adjusting knob a few turns counterclockwise (CCW) to decrease the pressure setting to a lower than desired pressure.
2. Connect the pump completely. Place the pump's rocker switch in the ON position.
3. Slowly turn the adjusting knob in a clockwise (CW) direction to gradually increase the pressure setting. When the desired pressure setting is reached, lock the adjusting knob into position by tightening the locking nut.

Pressure Switch

A pressure switch can be adjusted to stop the pump motor at a desired pressure setting and restart the motor when the pressure falls below that setting.

It is recommended that a pressure switch be used with a pressure regulating valve to insure accuracy when setting a maximum PSI level. A pressure switch alone will break the motor's energy supply at a selected setting, but the hydraulic pump will continue building pressure as it slows to a stop. The pressure regulating valve is adjusted at a setting slightly above the pressure switch setting to compensate by releasing the pressure developed by the hydraulic pump as it "coasts" to a stop. As a result, the pressure limit requirement can be held to approximately 300 PSI.

Adjusting The Pressure Switch Setting

1. Loosen the locknut on the pressure switch. Slowly turn the pressure switch adjusting screw in a counterclockwise (CCW) direction, decreasing the pressure switch setting until the pump motor shuts off. Tighten the locknut to lock the adjusting screw.
2. Release the hydraulic pressure. Run the pump to check the pressure setting and automatic shutoff of the motor. It may be necessary to make a second fine adjustment.

PREVENTIVE MAINTENANCE



WARNING To help avoid possible personal injury,

- **Disconnect the pump from the power supply before performing maintenance or repair procedures.**
- **Repairs and maintenance should be performed in a dust-free area by a qualified technician.**

Bleeding Air from the System

Air can accumulate in the hydraulic system. This air causes the cylinder to respond in an unstable or slow manner. To remove the air:

1. Position hydraulic cylinder(s) on their sides with the couplers located upward and at a lower level than the pump.
2. Remove any load from the cylinder(s), and cycle the hydraulic system through several cycles (fully extend and retract the cylinders).
3. The bladder must be vented and refilled (see "Filling the Bladder" section on sheet 2 of 3).

Hydraulic Fluid Level

1. Check the oil level in the bladder after each 10 hours of use. With all cylinders retracted and the pump in the upright (or vertical) position, the oil level should be at the top of the filler hole.
2. When adding oil, use Power Team approved, high-grade hydraulic oil (215 SSU @ 100°F). Retract the cylinders and disconnect the power supply. Clean the area around the filler plug, remove the plug, and insert a clean funnel with filter.
3. The frequency of oil changes will depend upon the general working conditions, severity of use, and overall cleanliness and care given the pump. Three hundred hours of use under general shop conditions is considered a standard change interval. Drain, flush, and refill the bladder with Power Team approved, high-grade hydraulic oil (215 SSU @ 100°F).

Maintenance and Cleaning

1. Keep the pump's outer surface as free from dirt as possible.
2. Seal all unused couplers with thread protectors.
3. Keep all hose connections free of dirt and grime.
4. Equipment connected to the pump must be kept clean.
5. Use only Power Team approved, high-grade hydraulic oil in this pump. Change as recommended (approx. every 300 hours).

**ELECTRICAL SCHEMATIC 115/230 V., 50/60 Hz,
SINGLE PHASE**

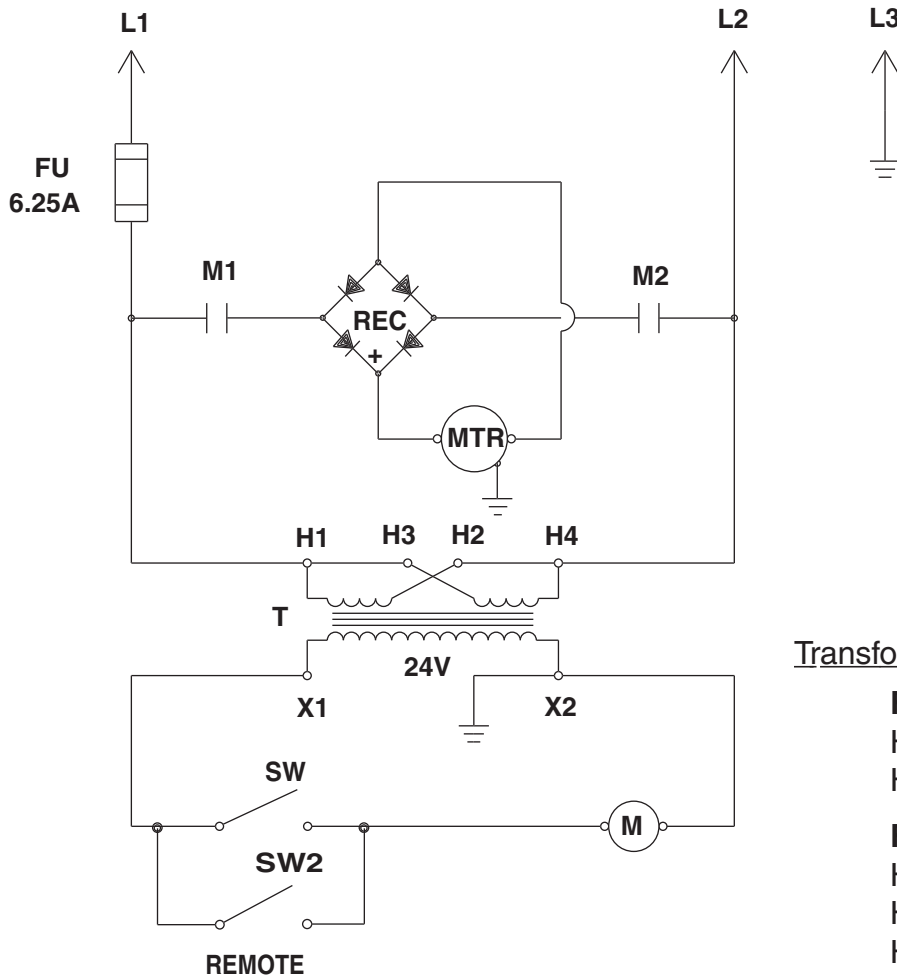

Transformer Connections:

For 115 VAC
H1 & H3 to L1
H2 & H4 to L2

For 230 VAC
H1 to L1
H2 to H3
H4 to L2

ELECTRICAL SCHEMATIC 12 VDC (CCW ROTATION FROM LEAD END)

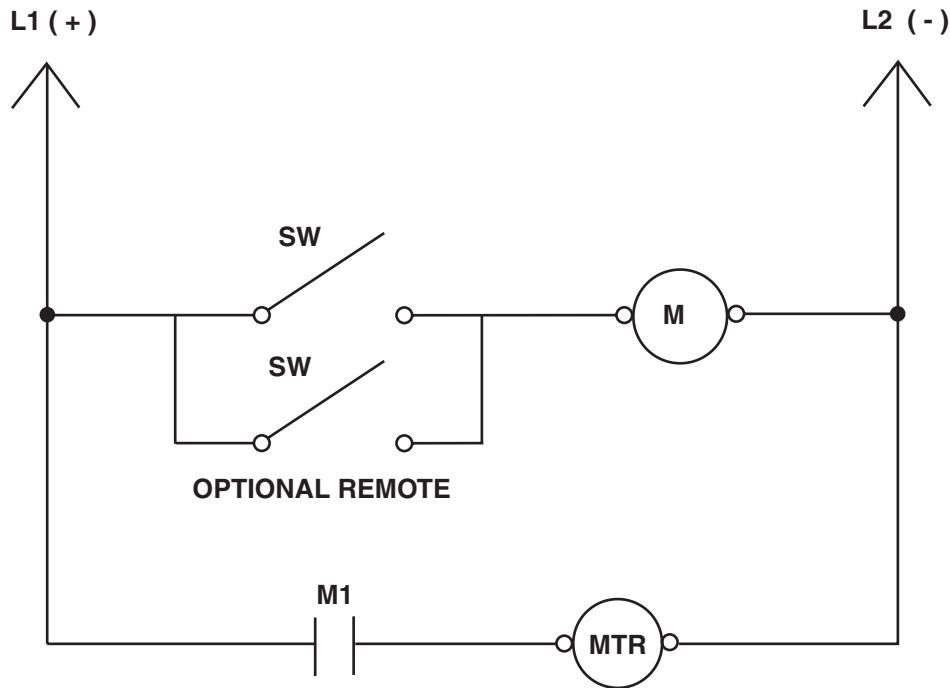

UNITED STATES

SPX Corporation-Fluid Power
5885 11th Street
Rockford, IL 61109-3699
USA
Telephone: 1-815-874-5556
FAX: 1-815-874-7853

Cust. Service/Order Entry

Tel: 1-800-541-1418
FAX: 1-800-288-7031

E-mail:
info@fluidpower.spx.com

Technical Services

Tel: 1-800-477-8326
FAX: 1-800-765-8326



CHINA

212 Jiang Ning Road
CATIC Tower 23C
Shanghai 200041, China
Tel: 86 (21) 5289 5858
FAX: 86 (21) 5289 5866
E-mail:
info.asia@fluidpower.spx.com



FAR EAST

7 Gul Circle
Singapore 628978
Singapore
Tel: (65) 6265-3343
FAX: (65) 6265-6646
E-mail:
info.asia@fluidpower.spx.com



EUROPE

Albert Thijsstraat 12
6471 WX Eyselshoven
Netherlands
Tel: 31 (45) 5678877
FAX: 31 (45) 5678878
E-mail:
info.europe@fluidpower.spx.com