

DOUBLE-ACTING HYDRAULIC CYLINDER

Max. Capacity: 107 Tons At 10,000 PSI

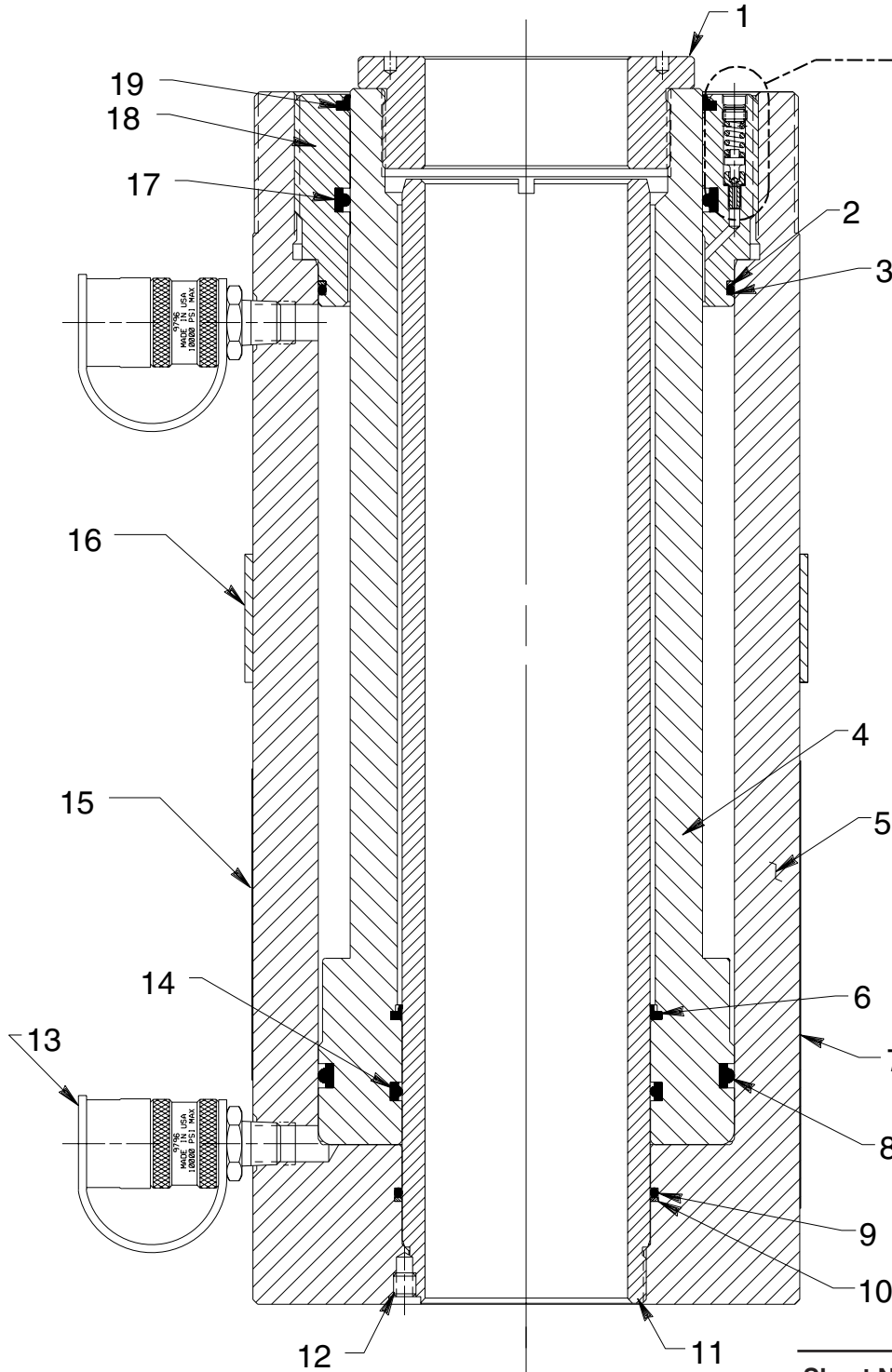

**Double-acting
Cylinder
Relief Valve**

See important
! DANGER
statement
on back of
sheet 1 of 1

Note: Shaded areas reflect last revision(s) made to this form.

See NOTE on back of sheet 1 of 1

Sheet No. 1 of 1

Rev. 3 Date: 19 Mar. 1999



DANGER: To help avoid possible serious personal injury or death,

- In the event that the cylinder retract port is ever restricted or plugged, a double-acting cylinder relief valve will help prevent excessive pressure from building in the cylinder. **DO NOT** attempt to adjust or service this relief valve! If oil leakage is detected from this relief valve, discontinue use of the cylinder immediately and contact Power Team Technical Services. Only Power Team Authorized Hydraulic Service Centers should service this relief valve.

Item No.	Part No.	No. Req'd	Description
1	350526	1	Threaded Piston Cap
2	*250832	1	Backup Washer (6-1/2 x 6-1/4 x .048)
3	*250831	1	O-ring (6-1/2 x 6-1/4 x 1/8)
4	58287	1	Piston
5	64320	1	Cylinder Body
6	*205775	1	Rod Wiper
7	250807	1	Trade Name Decal
8	*214495	1	T-seal Packing (Piston)
9	*10298	1	O-ring (4-1/8 X 3 -7/8 X 1/8)
10	*19170	1	Backup Washer (4-1/8 x 3-7/8 x .048)
11	350525	1	Standpipe (Note: Bottom out and back off [.01] 1/8 revolution before adding set screw [molykote all threads].)
12	10556	1	Set Screw (1/4-20 UNC X 1/4 Lg.; See NOTE below)
13	9796	2	Ram Half Coupler w/ Plastic Dust Cap
14	*250830	1	T-seal Packing (Standpipe)
15	*37782	1	Warning Decal
16	420485OR9	1	Cylinder Lift Handle Assembly
17	*250833	1	T-seal Packing (Rod)
18	58288	1	Retainer Nut
19	*207593	1	Wiper Ring

PARTS INCLUDED BUT NOT SHOWN

421276	1	Thread Protector
--------	---	------------------

Part numbers marked with an asterisk (*) are contained in Repair Kit No. 300629.

NOTE: Cylinders built after 1-1-99 do not use this set screw to lock the standpipe and cylinder body together. Loctite 242 is used on last 2-3 standpipe threads only.

Refer to any operating instructions included with this product for detailed information about operation, testing, assembly, disassembly, and preventive maintenance.

Items found in this parts list have been carefully tested and selected. **Therefore: Use only genuine Power Team replacement parts!**

Additional questions can be directed to our Technical Services Department.

Note: Shaded areas reflect last revision(s) made to this form.