

Parts List for:

	PE302-220	PE303-2-220
PE30-HOGEN	PE302-2-220	PE304
PE30-HOGEN-115	PE303	PE304-2
PE302	PE303-2	PE304-220
PE302-2	PE303-220	PE304-2-220

MODEL B ELECTRIC HYDRAULIC PUMP Max. Capacity: 10,000 PSI

This view illustrates models with a 1-3/4 gallon reservoir.

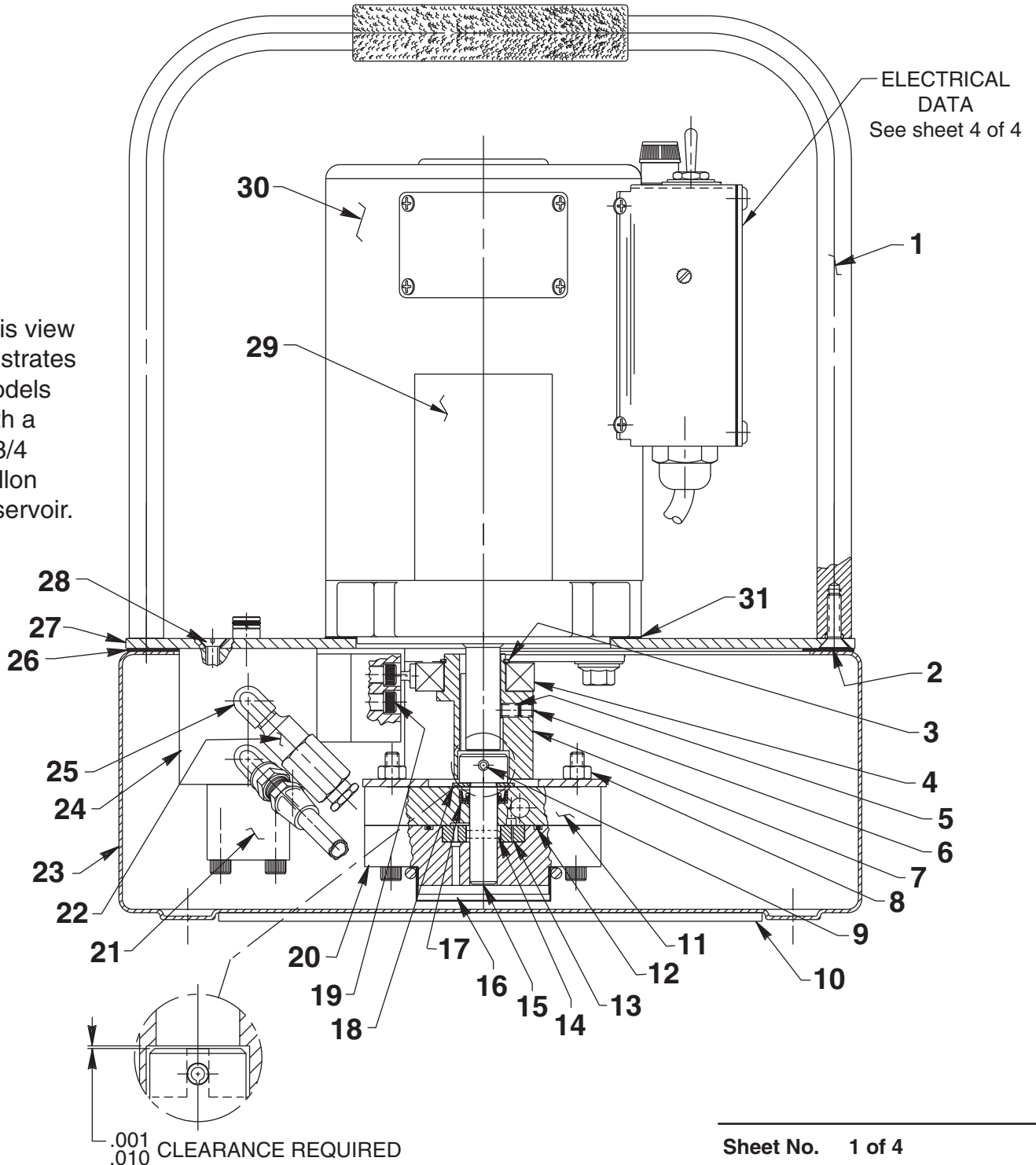

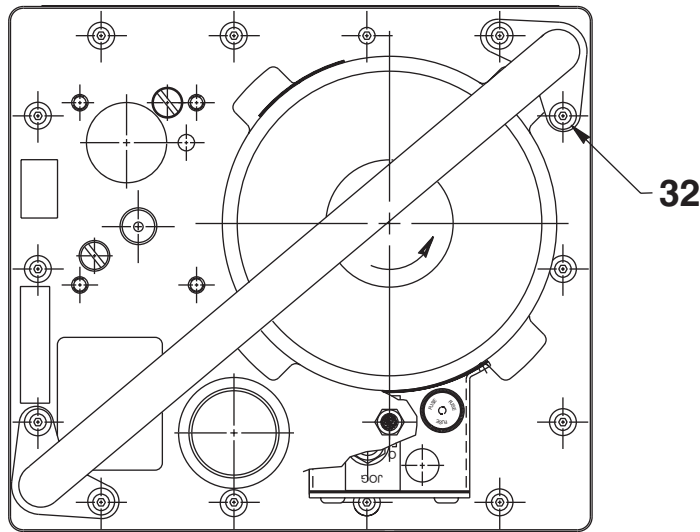

This view illustrates the handle orientation, and its mounting, on models with a one gallon reservoir.

Item No.	Part No.	No. Req'd	Description
1	64677BK2	1	Handle (For PE302, PE302-220, PE303, PE303-220, PE304 & PE304-220)
	64582BK2	2	Roll Cage Frame (For PE302-2, PE302-2-220, PE303-2, PE303-2-220, PE304-2 & PE304-2-220)
2	11529	4	Cap Screw (1/4-20 UNC x 3/4 Lg.; Apply Loctite No. 242 or equiv. and torque to 70 in. lbs. - For PE302-2, PE302-2-220, PE303-2, PE303-2-220, PE304-2 & PE304-2-220)
3	209798	1	Retaining Ring
4	209805	1	Ball Bearing
5	10136	1	Set Screw (1/4-20 UNC x 1/4 Lg.; Torque to 70 in. lbs.)
6	10519	1	Set Screw (1/4-20 UNC X 3/8 Lg.; Torque to 70 in. lbs.)
7	420840	1	Eccentric
8	10199	2	Hex Nut (1/4-20 UNC)
9	12298	1	Roll Pin (3/16 dia. x 1-1/2" Lg.)
10	420427	1	Rubber Pad (For PE302-2, PE302-2-220, PE303-2, PE303-2-220, PE304-2, PE304-2-220, PE30-HOGEN & PE30-HOGEN-115)
11	64623	1	Upper Gerotor Housing
12	10922	1	O-ring (2-1/8" X 1-15/16" X 3/32)
13	304826	1	Gerotor
14	209794	1	Gerotor Drive Pin
15	350940	1	Gerotor Shaft
16	21846	1	Filter Support
17	304830	1	Oil Seal
18	12595	1	Washer (1-1/8" X 1/2 X .077 Thk.)
19	10022	4	Screw (1/4-20 UNC X 1-1/2" Lg.; Torque to 190 in. lbs.)
20	64580	1	Gerotor Housing
21	350930	1	Retaining Block
22	21278	1	Relief Valve Assembly (Set at 10,100/10,700 PSI)
23	64665OR9	1	Reservoir (1 Gal. - For PE302, PE302-220, PE303, PE303-220, PE304 & PE304-220)
	64241OR9	1	Reservoir (2 Gal. - For PE302-2, PE302-2-220, PE303-2, PE303-2-220, PE304-2, PE304-2-220, PE30-HOGEN, & PE30-HOGEN-115)
24	64612	1	Check Body

Item No.	Part No.	No. Req'd	Description
25	13229	1	Street Elbow
26	420931	1	Reservoir Gasket (For PE302, PE302-220, PE303, PE303-220, PE304 & PE304-220)
	420424	1	Reservoir Gasket (For PE302-2, PE302-2-220, PE303-2, PE303-2-220, PE304-2, PE304-2-220, PE30-HOGEN & PE30-HOGEN-115)
27	64666BK2	1	Cover Plate (For PE302, PE302-220, PE303, PE303-220, PE304 & PE304-220)
	64579BK2	1	Cover Plate (For PE302-2, PE302-2-220, PE303-2, PE303-2-220, PE304-2, PE304-2-220, PE30-HOGEN & PE30-HOGEN-115)
28	11529	2	Screw (1/4-20 UNC x 3/4 Lg.)
29	200188	1	Decal
30	*420838BK2	1	Electric Motor (110/115 V.; For PE302, PE302-2, PE303, PE303-2, PE304, PE304-2 & PE30-HOGEN-115)
	**420839BK2	1	Electric Motor (220/230 V.; For PE302-220, PE302-2-220, PE303-220, PE303-2-220, PE304-220, PE304-2-220, & PE30-HOGEN)
31	351060	1	Motor Base Gasket
32	15911	2	Cap Screw (1/4-20 5/8 Lg.; Apply Loctite No. 242 or equiv. and torque to 70 in. lbs. - For PE302, PE302-220, PE303, PE303-220, PE304 & PE304-220)

PARTS INCLUDED BUT NOT SHOWN

25229	1	Cord Set (115 V.; For PE302, PE302-2, PE303, PE303-2, PE304, PE304-2 & PE30-HOGEN-115)
308752	1 ft.	Electrical Cable (220 V.; For PE302-220, PE302-2-220, PE303-220, PE303-2-220, PE304-220, PE304-2-220, & PE30-HOGEN)

* Note: For Replacement brushes, order (2) #252958.

** Note: For Replacement brushes, order (2) #252961.

HIGH PRESSURE PUMP ASSEMBLY

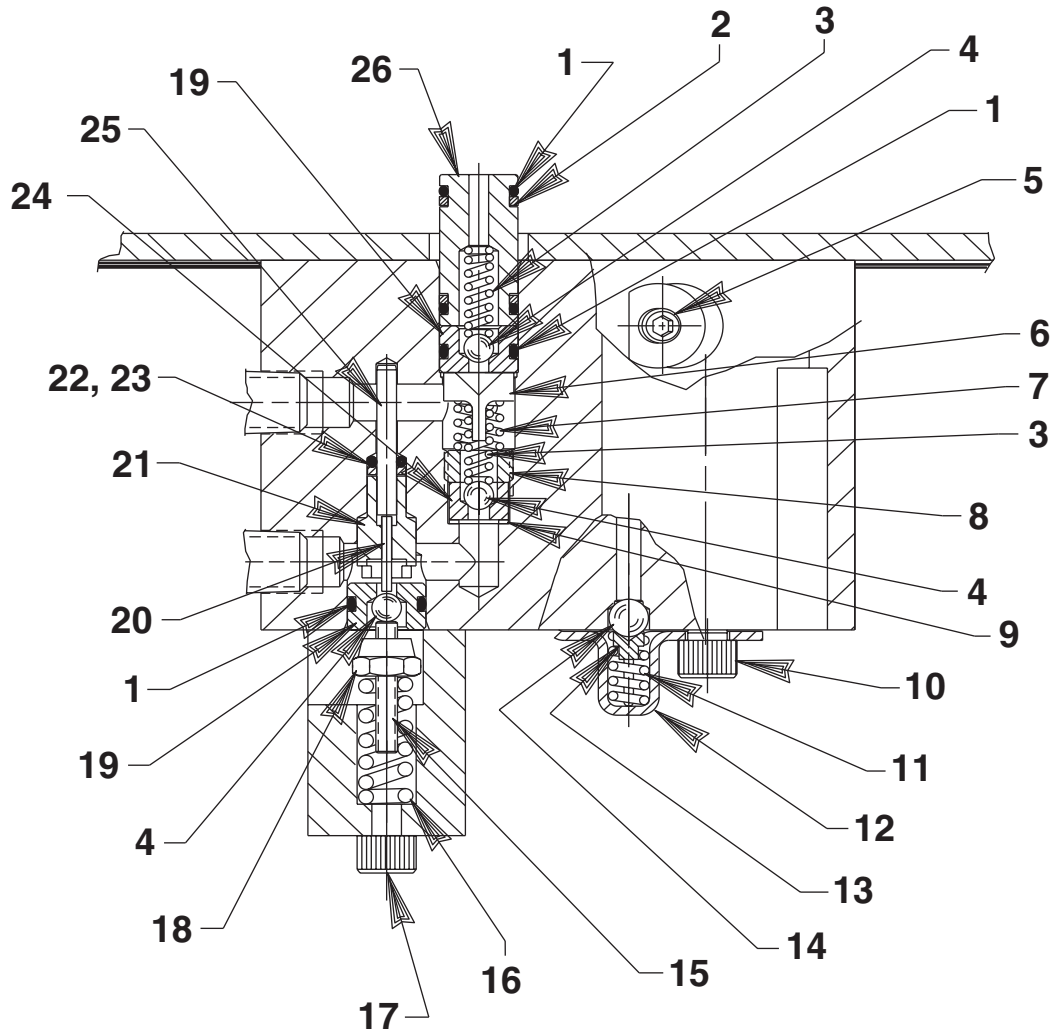

Item No.	Part No.	No. Req'd	Description
1	10268	4	O-ring (1/2 X 3/8 X 1/16)
2	11863	2	Backup Washer (1/2 X 3/8 X 1/16)
3	10445	2	Compression Spring (5/32 O.D. X 3/4 Lg.)
4	15130	1	Plug (1/16 NPTF)
5	251601	1	Outlet Ball Stop
6	10444	1	Compression Spring (3/16 I.D. X 13/32 Lg.)
7	209797	1	Hollow Lock Screw (7/16-20 UNF-3A; Torque to 120 in. lbs.)
8	12223	4	Ball (3/16 Dia.)
9	10442	1	Washer (3/8 X 1/4 X 1/32)
10	10374	1	Steel Ball (7/32 Dia.)
11	15691	1	Compression Spring (1/4 O.D. X 5/8 Lg.)
12	350577	1	Spring Retainer
13	200796	1	Adapter

Item No.	Part No.	No. Req'd	Description
14	10002	1	Cap Screw (1/4-20 UNC X 3/8 Lg.; Torque to 70 in. lbs.)
15	251067	1	Set Screw (Unloading valve; #10-24 UNC x 1" Lg.)
16	14484	1	Compression Spring (3/8 O.D. X 1" Lg.)
17	10854	2	Cap Screw (1/4-20 UNC X 1-3/4" Lg.; Torque to 70 in. lbs.)
18	207405	1	Locknut (10-24 UNC)
19	251065	2	Replaceable Seat
20	251611	1	Dowel Pin (1/2 x 3/8 x .049)
21	251068	1	Guide
22	17797	1	O-ring (1/4 X 1/8 X 1/16)
23	214992	1	Backup Ring (15/64 x 1/8 x 3/64)
24	209787	1	Replaceable Seat
25	16471	1	Dowel Pin (1/8 dia. x 1" Lg.; Taper on pin should be away from Guide [Item #21].)
26	251581	1	Bushing

TOP VIEW

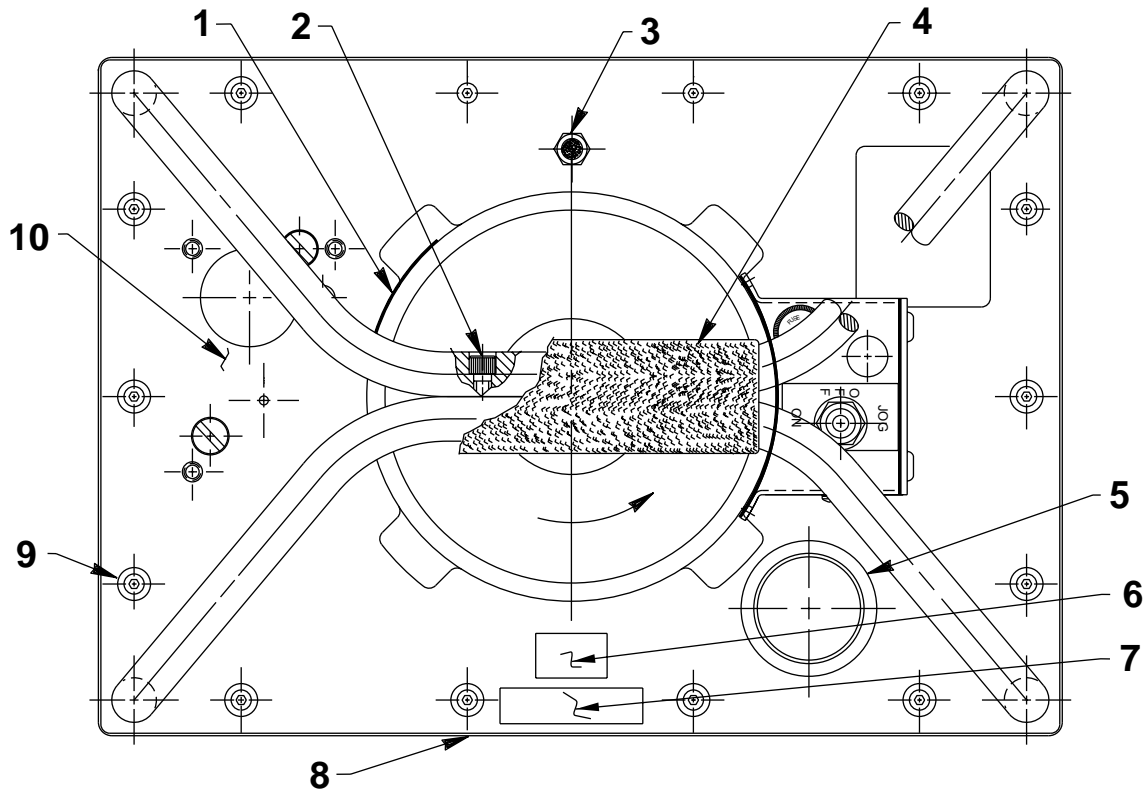

Item No.	Part No.	No. Req'd	Description
1	351024	1	Decal
2	10008	2	Cap Screw (For PE302-2, PE302-2-220, PE303-2, PE303-2-220, PE304-2 & PE304-2-220 only)
3	251599	1	Breather Filter Vent
4	251600	1	Handle Grip (For PE302-2, PE302-2-220, PE303-2, PE303-2-220, PE304-2, PE304-2-220 only)
5	350925	1	Filler Cap
6	203972	1	Decal (CSA logo)
7	213695	1	Decal (Intermittent Duty)
8	309219	2	Trade Name Decal (For PE302, PE302-220, PE303, PE303-220, PE304 & PE304-220)
	309221	2	Trade Name Decal (For PE302-2, PE302-2-220, PE303-2, PE303-2-220, PE304-2, PE304-2-220, PE30-HOGEN & PE30-HOGEN-115)
9	10177	14	Cap Screw (1/4-20 X 3/4 Lg.; Torque to 60/80 in. lbs.)
10	9584	1	Valve Assembly (For PE302, PE302-2, PE302-220 & PE302-2-220; See Form No. 101239; Note: When ordering this valve also order (4) 10890 Cap Screws for mounting valve to pump.)
	9520	1	Valve Assembly (For PE303, PE303-2, PE303-220 & PE303-2-220; Apply Loctite #242 to threads of valve handle stem [both end]. - See Form No. 101377; Note: When ordering this valve also order (4) 10890 Cap Screws for mounting valve to pump.)
	52516	1	Valve Assembly (For PE304, PE304-220 & PE304-2-220; Apply Loctite #242 to threads of valve handle stem [both end]. - See Form No. 100623; Note: When ordering this valve also order (4) 11956 Cap Screws for mounting valve to pump.)
	60916	1	Pressure Compensated Valve (For PE30-HOGEN & PE30-HOGEN-115; See Form No. 101373; Note: When ordering this valve also order (4) 251078 Cap Screws and (4) 10245 lockwashers for mounting valve to pump.)
OPTIONAL VALVES			
	9628	1	Manual Valve (See Form No. 101907; Note: When ordering this valve also order (4) 10890 Cap Screws for mounting valve to pump.)

BOTTOM VIEW AND SECTION A-A

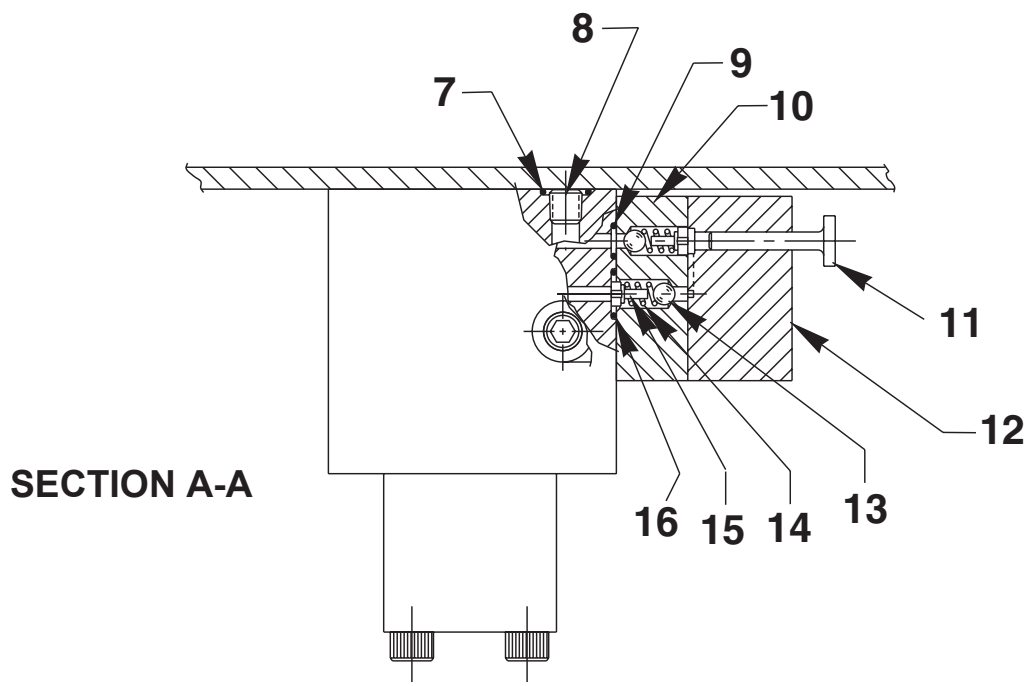
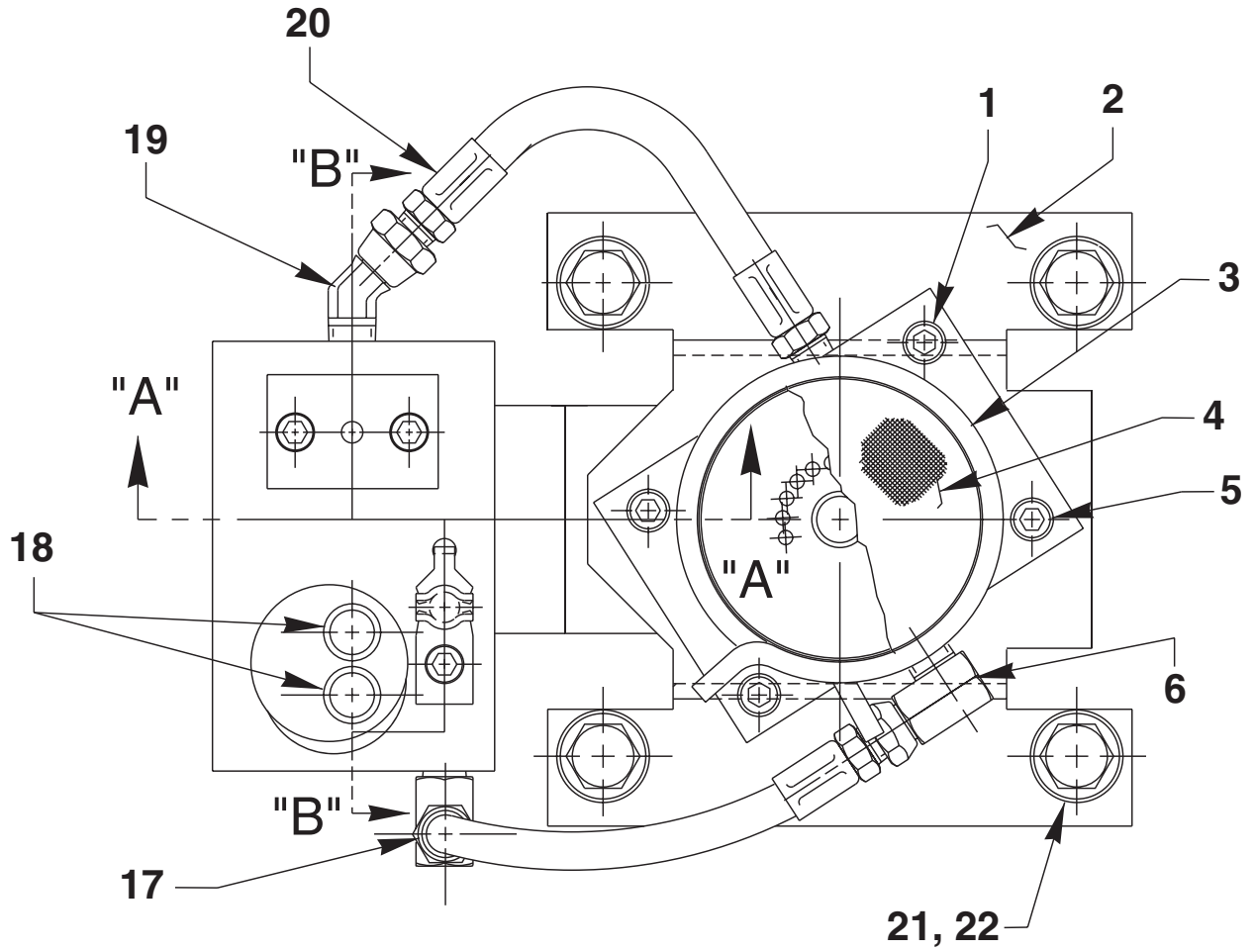

Parts List, Form No. 101856, Back sheet 3 of 4

Item No.	Part No.	No. Req'd	Description	Item No.	Part No.	No. Req'd	Description
1	10022	2	Cap Screw (1/4-20 UNC X 1-1/2" Lg.; Torque to 70 in. lbs.)	16	14763	1	O-ring (7/16 X 5/16 X 1/16)
2	58481	1	Gerotor Housing Bracket	17	13229	1	Elbow
3	11461	1	Hose Clamp	18	250630	1	Drain Tube (For PE302, PE302-2, PE302-220, PE304, PE304-2, PE304-220 & PE304-2-220)
4	21608	1	Filter		250630	2	Drain Tube (For PE303, PE303-2, PE303-220 & PE303-2-220)
5	10890	2	Cap Screw (1/4-20 X 2" Lg.)		12360	1	Drain Tube (For PE30-HOGEN & PE30-HOGEN-115)
6	14440	1	90° Elbow Fitting	19	251800	1	Elbow Fitting
7	15279	1	O-ring (1/2 X 3/8 X 1/16)	20	304819	2	Hose Assembly
8	15130	1	Plug (1/16 NPTF)	21	213663	4	Screw (3/8-16 UNC X 1" Lg.)
9	10265	1	O-ring (5/16 X 3/16 X 1/16)	22	10258	4	Washer (For 3/8 bolt)
10	45559	1	Block				
11	305526	1	High Pressure Piston				
12	45866	1	Block				
13	12223	1	Ball (3/16 Dia.)				
14	10445	1	Compression Spring (5/32 O.D. X 3/4 Lg.)				
15	24549	2	Ball Guide				

HYDRAULIC SCHEMATIC

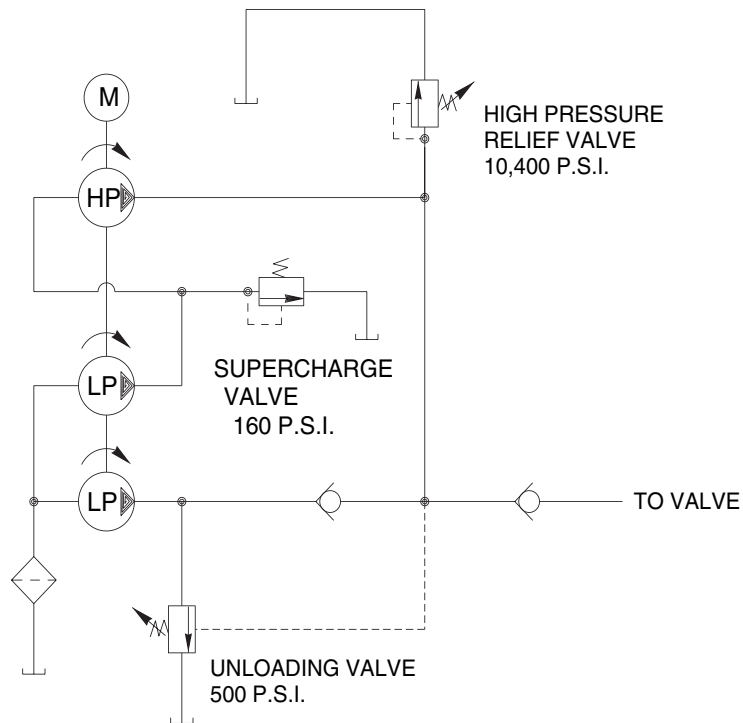

Refer to any operating instructions included with this product for detailed information about operation, testing, disassembly, reassembly, and preventive maintenance.

Items found in this parts list have been carefully tested and selected. **Therefore: Use only genuine Power Team replacement parts!**

Additional questions can be directed to our Technical Services Department.

ELECTRICAL DATA 110/115 V., 50/60 Hz.

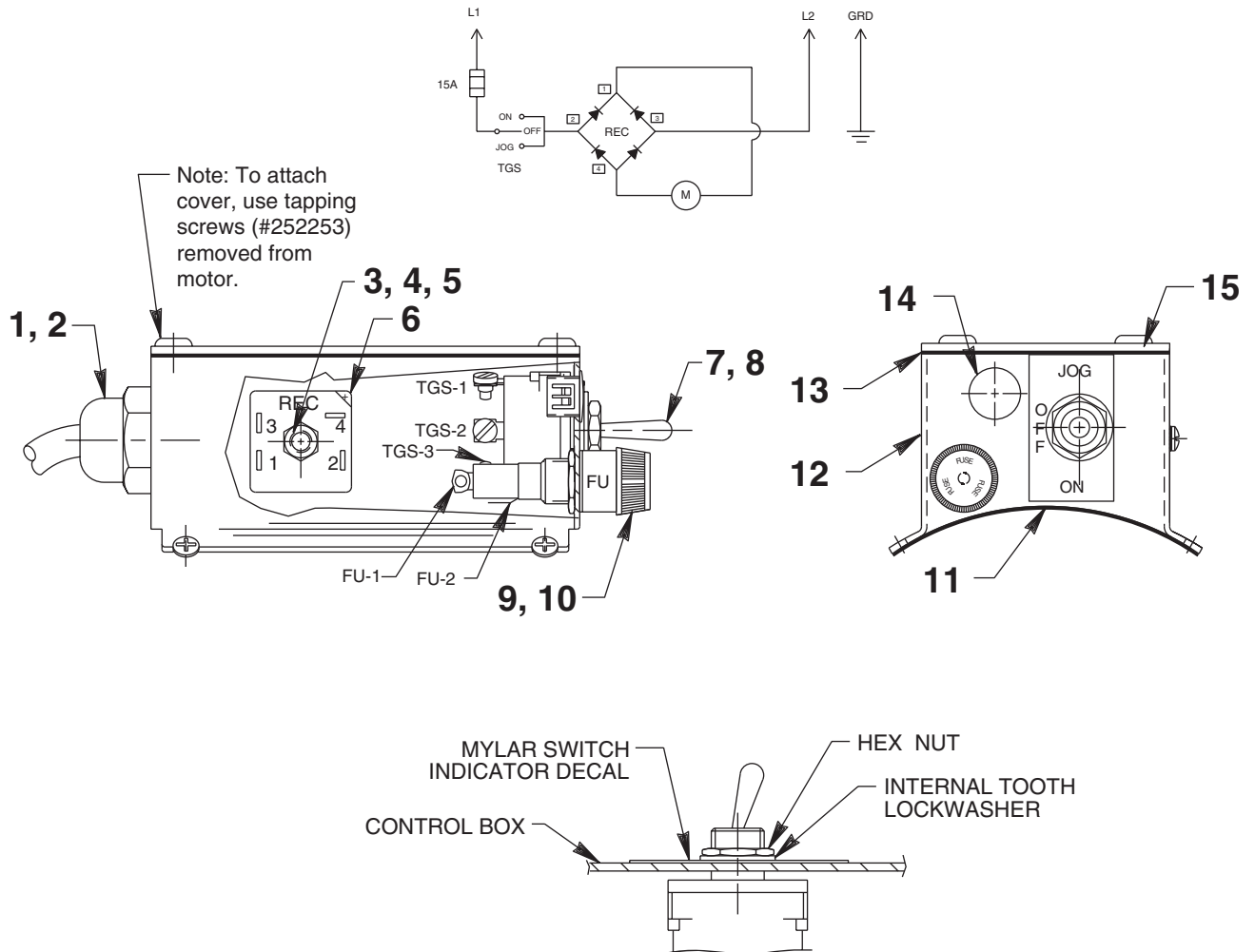

Item No.	Part No.	No. Req'd	Description
1	216666	1	Strain Relief Bushing
2	216680	1	Conduit Locknut
3	10167	1	Screw (10-24 x 3/4 Lg.)
4	11108	1	Washer
5	10197	1	Hex Nut (10-24)
6	251050	1	Rectifier
7	350980	1	Toggle Switch
8	25926	1	Decal (Switch Indicator)
9	18292	1	Fuse Holder

Item No.	Part No.	No. Req'd	Description
10	252288	1	Fuse (15 AMP)
11	252992	1	Conduit Box Gasket
12	59037BK2	1	Control Box
13	252991	1	Conduit Box Cover Gasket
14	17782	1	Snap Plug
15	252990	1	Conduit Box Cover

PARTS INCLUDED BUT NOT SHOWN
25229 1 Cord Set (8 ft. lg.)

ELECTRICAL DATA 220/230 V., 50/60 Hz.

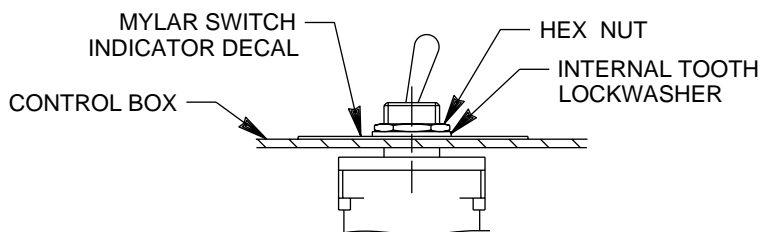
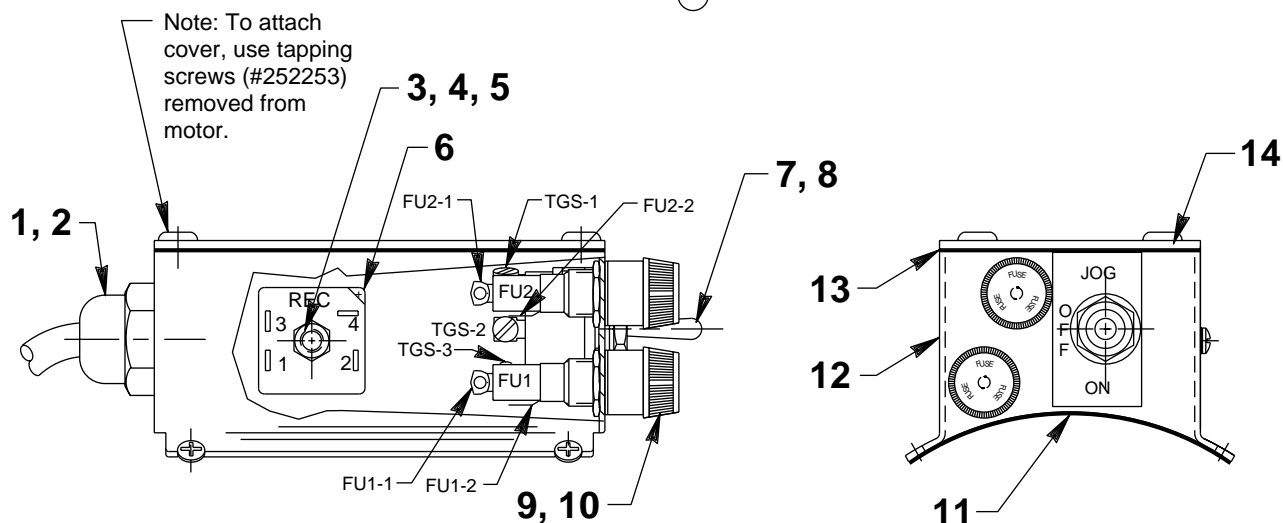
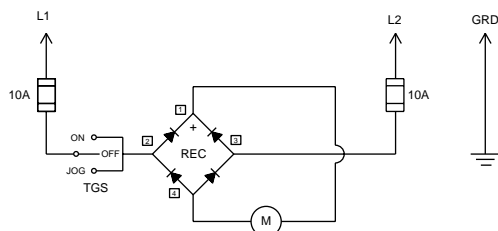

Item No.	Part No.	No. Req'd	Description
1	216666	1	Strain Relief Bushing
2	216680	1	Conduit Locknut
3	10167	1	Screw (10-24 x 3/4 Lg.)
4	11108	1	Washer
5	10197	1	Hex Nut (10-24)
6	251050	1	Rectifier
7	350980	1	Toggle Switch
8	25926	1	Decal (Switch Indicator)
9	18292	2	Fuse Holder

Item No.	Part No.	No. Req'd	Description
10	252873	2	Fuse (15 AMP)
11	252992	1	Conduit Box Gasket
12	59037BK2	1	Control Box
13	252991	1	Conduit Box Cover Gasket
14	252990	1	Conduit Box Cover

PARTS INCLUDED BUT NOT SHOWN
308752 9 ft. Electrical Cable (14/3 SJTO)