

Parts List for:

- PE302S
- PE302S-2
- PE302S-220
- PE302S-2-220
- PE302S-HENN

## ELECTRIC HYDRAULIC PUMP

Max. Capacity: 10,000 PSI

This view illustrates models with a 1-3/4 gallon reservoir.

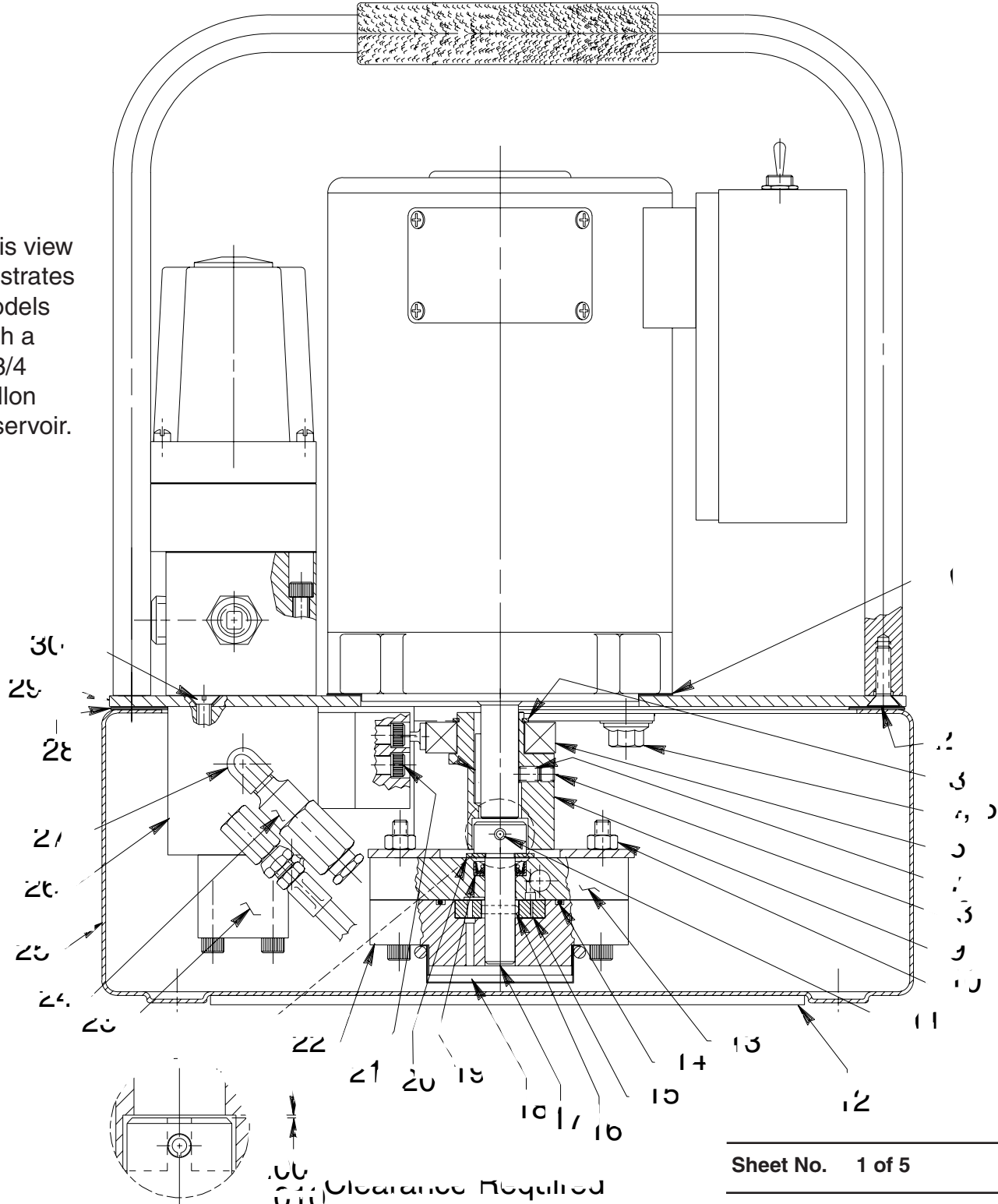

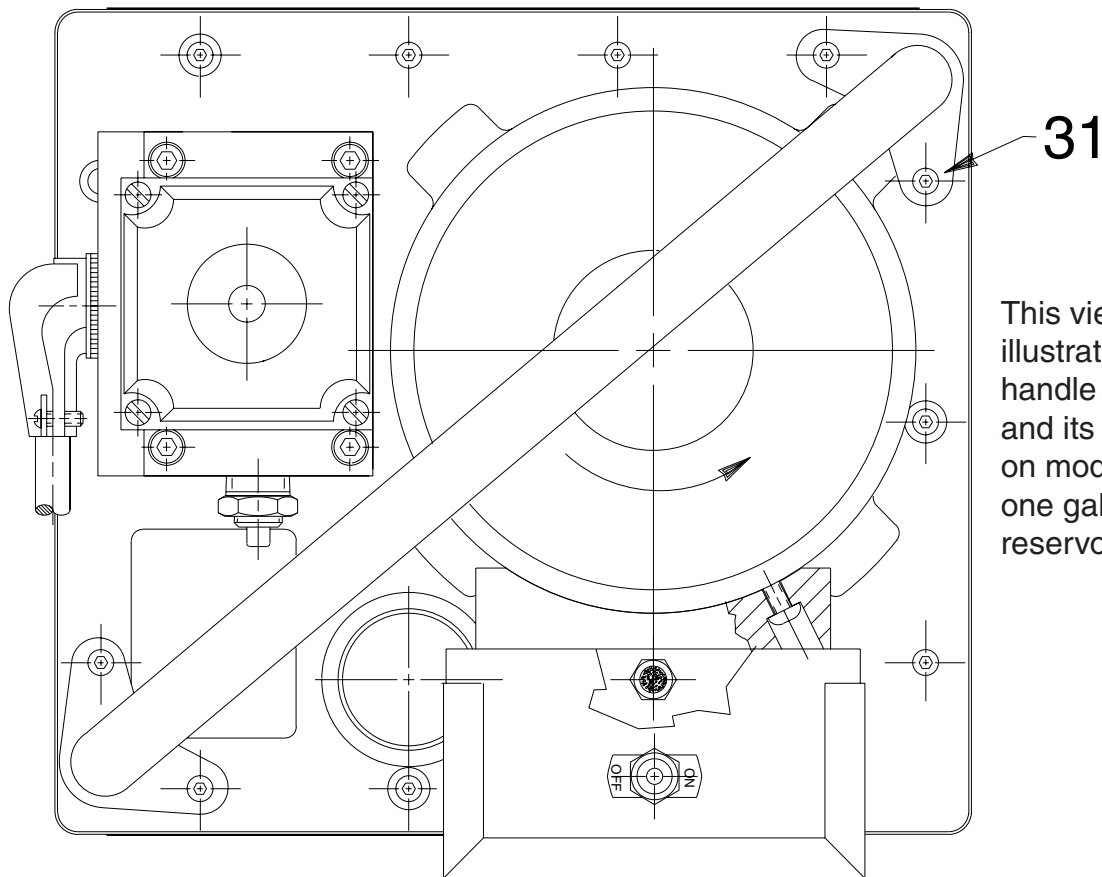

This view illustrates the handle orientation, and its mounting, on models with a one gallon reservoir.

Item No.	Part No.	No. Req'd	Description
1	351060	1	Motor Base Gasket
2	11529	4	Cap Screw (1/4-20 UNC x 3/4 Lg.; Apply Loctite No. 242 or equiv. and torque to 70 in. lbs. For PE302S-2, & PE302S-2-220)
3	209798	1	Retaining Ring
4	213663	4	Cap Screw (3/8-16 UNC X 1" Lg.)
5	10258	4	Washer (For 3/8 bolt)
6	209805	1	Ball Bearing
7	10136	1	Set Screw (1/4-20 UNC x 1/4 Lg.; Torque to 60/80 in. lbs.)
8	10519	1	Set Screw (1/4-20 UNC X 3/8 Lg.; Torque to 60/80 in. lbs.)
9	420840	1	Eccentric
10	10199	2	Hex Nut (1/4-20 UNC)
11	12298	1	Roll Pin (3/16 dia. x 1-1/2" Lg.)
12	420427	1	Rubber Pad (For PE302S-2 & PE302S-2-220)
	420948	1	Rubber Pad (For PE302S, PE302S-220 & PE302S-HENN)
13	64623	1	Upper Gerotor Housing
14	10922	1	O-ring (2-1/8" X 1-15/16" X 3/32)
15	304826	1	Gerotor
16	209794	1	Gerotor Drive Pin
17	350940	1	Gerotor Shaft
18	21846	1	Filter Support
19	304830	1	Oil Seal
20	12595	1	Washer (1-1/8" X 1/2 X .077 Thk.)

Item No.	Part No.	No. Req'd	Description
21	10022	4	Screw (1/4-20 UNC X 1-1/2" Lg.; Torque to 190 in. lbs.)
22	64580	1	Gerotor Housing
23	350930	1	Retaining Block
24	21278	1	Relief Valve Assembly (Set at 10,100/10,700 PSI; For all models\ except PE302S-HENN)
	21278-50	1	Relief Valve Assembly (Set at 5,100/5,700 PSI; FOR PE302S-HENN)
25	64665OR9	1	Reservoir (1 Gal. - For PE302S, PE302S-220 & PE302S-HENN)
	64241OR9	1	Reservoir (2 Gal. - For PE302S-2 & PE302S-2-220)
26	64612	1	Check Body
27	13229	1	Street Elbow
28	420931	1	Reservoir Gasket (1 Gal. - For PE302S, PE302S-220 & PE302S-HENN)
	420424	1	Reservoir Gasket (2 Gal. - For PE302S-2 & PE302S-2-220)
29	64666BK2	1	Cover Plate (For PE302S, PE302S-220 & PE302S-HENN)
	64579BK2	1	Cover Plate (For PE302S-2 & PE302S-2-220)
30	11529	2	Screw (1/4-20 UNC x 3/4 Lg.)
31	15911	4	Cap Screw (1/4-20 5/8 Lg.; Apply Loctite No. 242 or equiv. and torque to 70 in. lbs.; For PE302S, PE302S-220 & PE302S-HENN)

### HIGH PRESSURE PUMP ASSEMBLY

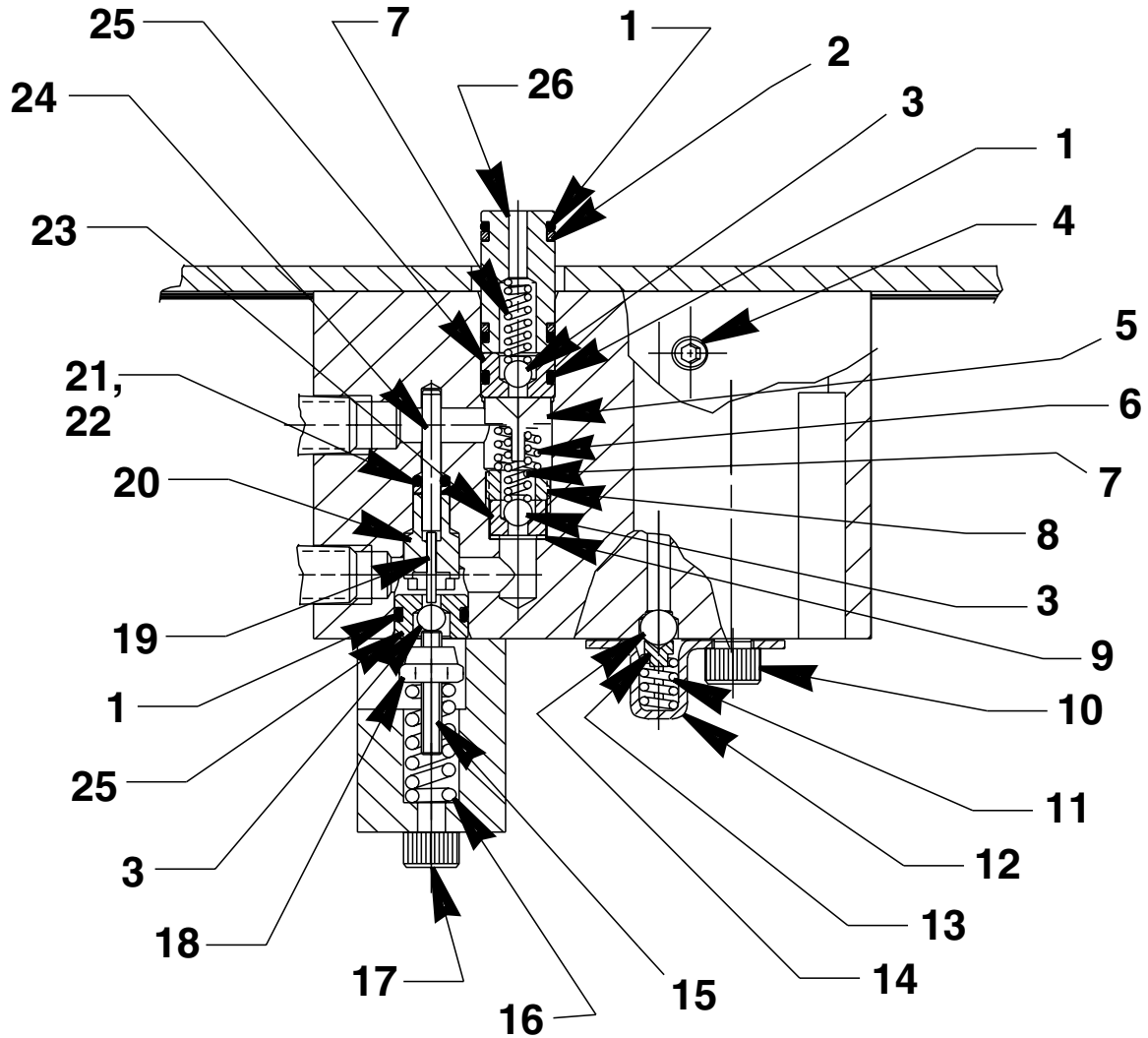

Item No.	Part No.	No. Req'd	Description	Item No.	Part No.	No. Req'd	Description
1	10268	4	O-ring (1/2 X 3/8 X 1/16)	12	350577	1	Spring Retainer
2	11863	2	Backup Washer (1/2 X 3/8 X 1/16)	13	200796	1	Adapter
3	12223	3	Ball (3/16 Dia.)	14	10374	1	Steel Ball (7/32 Dia.)
4	15130	1	Plug (1/16 NPTF)	15	251067	1	Set Screw (Unloading valve; #10-24 UNC x 1" Lg.)
5	251601	1	Outlet Ball Stop	16	14484	1	Compression Spring (3/8 O.D. X 1" Lg.)
6	10444	1	Compression Spring (3/16 I.D. X 13/32 Lg.)	17	10854	2	Cap Screw (1/4-20 UNC X 1-3/4" Lg.; Torque to 60/80 in. lbs.)
7	10445	2	Compression Spring (5/32 O.D. X 3/4 Lg.)	18	207405	1	Locknut (10-24 UNC)
8	209797	1	Hollow Lock Screw (7/16-20 UNF-3A; Torque to 110/130 in. lbs.)	19	251611	1	Dowel Pin (1/2 x 3/8 x .049)
9	10442	1	Washer (3/8 X 1/4 X 1/32)	20	251068	1	Guide
10	10002	1	Cap Screw (1/4-20 UNC X 3/8 Lg.; Torque to 60/80 in. lbs.)	21	17797	1	O-ring (1/4 X 1/8 X 1/16)
11	15691	1	Compression Spring (1/4 O.D. X 5/8 Lg.)	22	214992	1	Backup Ring (15/64 x 1/8 x 3/64)
				23	209787	1	Replaceable Seat
				24	16471	1	Dowel Pin (1/8 dia. x 1" Lg.)
				25	251065	2	Replaceable Seat
				26	251581	1	Bushing

TOP VIEW

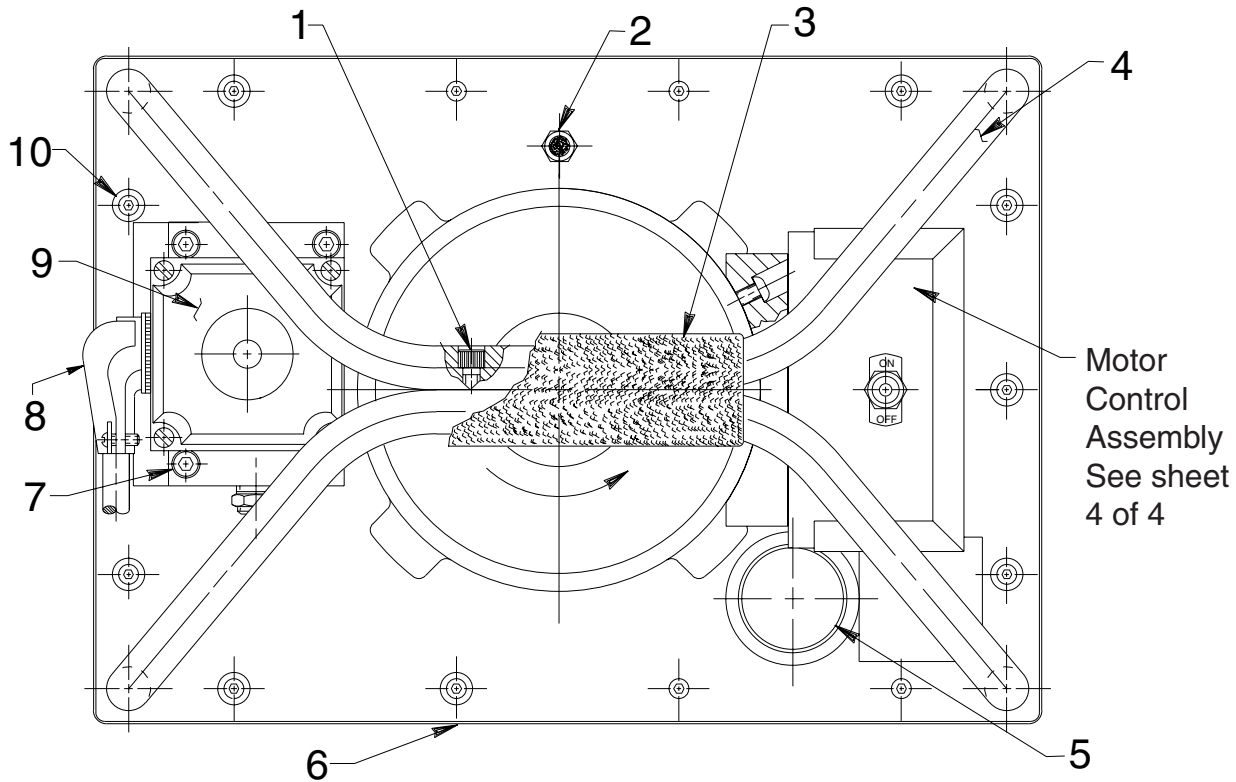

Item No.	Part No.	No. Req'd	Description
1	10008	2	Cap Screw (For PE302S-220 & PE302S-2-220 only)
2	251599	1	Breather Filter Vent
3	251600	1	Handle Grip (For PE302S-220 & PE302S-2-220 only)
4	64677BK2	1	Handle (For PE302S, PE302S-220 & PE302S-HENN)
	64582BK2	1	Roll Cage Frame (For PE302S-2 & PE302S-2-220)
5	350925	1	Filler Cap
6	309219	2	Trade Name Decal (For PE302S, PE302S-220 & PE302S-HENN)
	309221	2	Trade Name Decal (For PE302S-2 & PE302S-2-220)
7	10856	4	Cap Screw
8	11144	1	90° Connector
9	42621	1	Solenoid Valve Assembly (For PE302S, PE302S-2 & PE302S-HENN; See Form No. 100445)
	44084	1	Solenoid Valve Assembly (For PE302S-220 & PE302S-2-220; See Form No. 100445)
10	15911	14	Cap Screw (1/4-20 X 5/8 Lg.; Torque to 60/80 in. lbs. Note: On models with a one gallon reservoir, four of these mount the handle also [see back sheet 1 of 5].)

Refer to any operating instructions included with this product for detailed information about operation, testing, disassembly, reassembly, and preventive maintenance.

Items found in this parts list have been carefully tested and selected. **Therefore: Use only genuine Power Team replacement parts!**

Additional questions can be directed to our Technical Services Department.

**BOTTOM VIEW AND SECTION A-A**

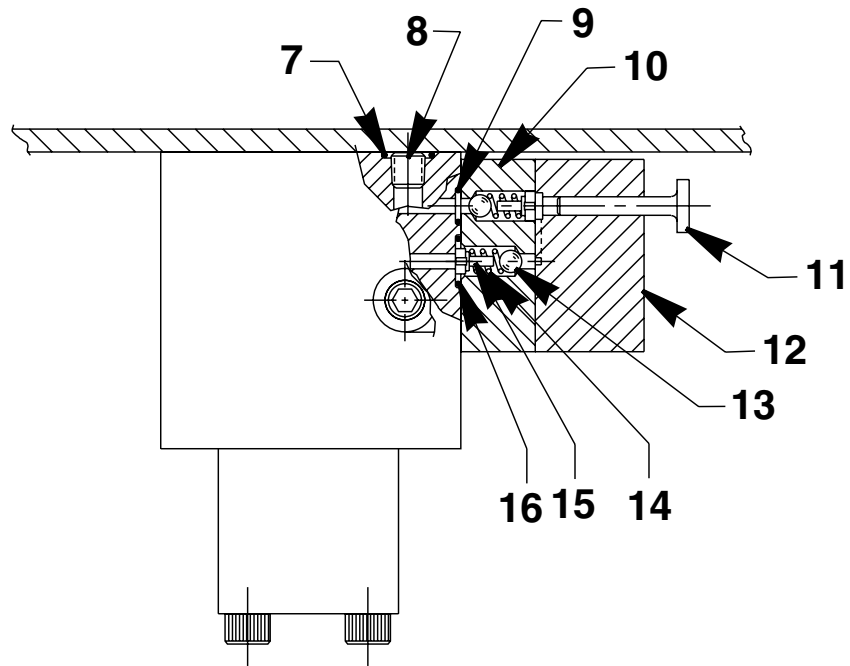
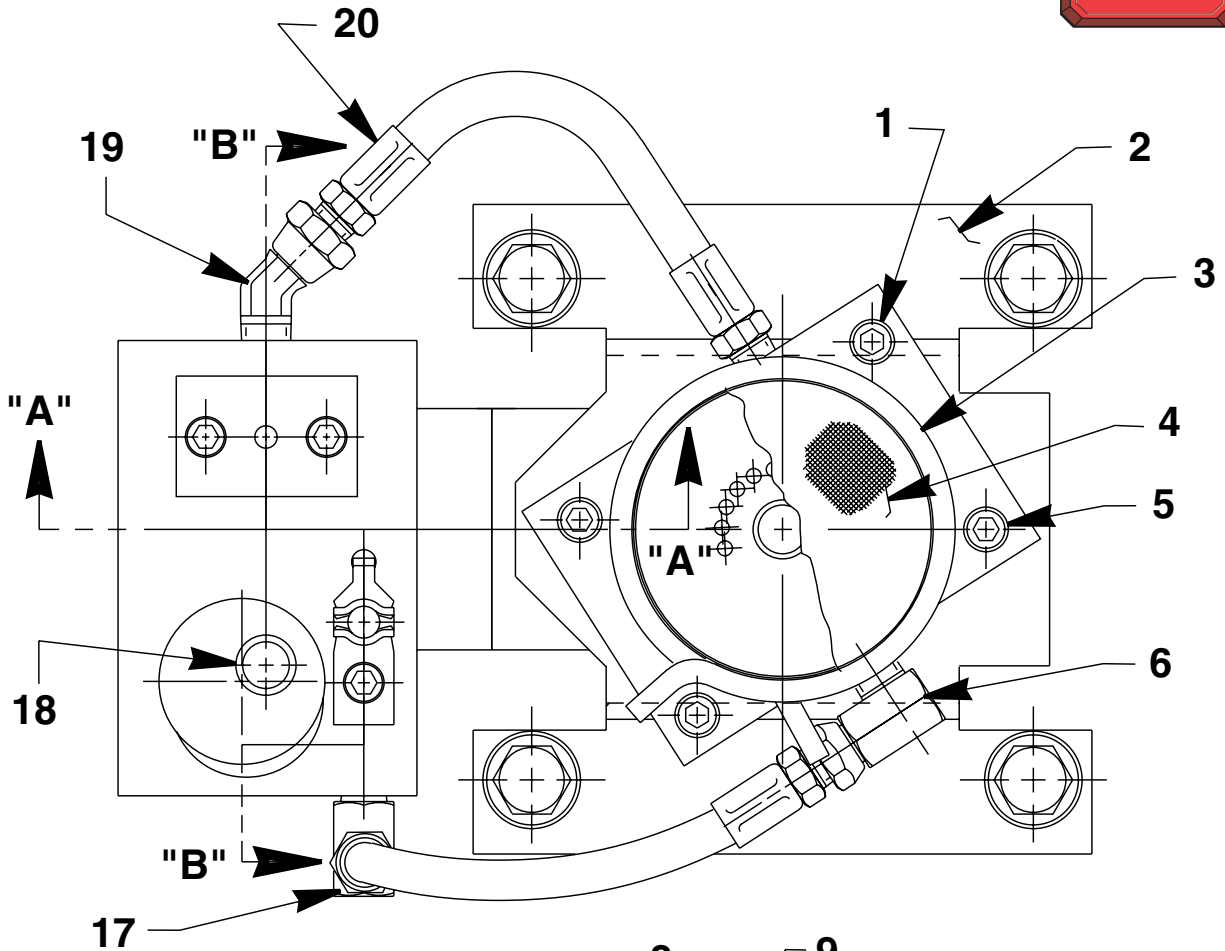

**Section A-A**

Item No.	Part No.	No. Req'd	Description
1	10022	2	Cap Screw (1/4-20 UNC X 1-1/2" Lg.; Torque to 60/80 in. lbs.)
2	58481	1	Gerotor Housing Bracket
3	11461	1	Hose Clamp
4	21608	1	Filter
5	10890	2	Cap Screw (1/4-20 X 2" Lg.; Torque to 60/80 in. lbs.)
6	14440	1	90° Elbow Fitting
7	15279	1	O-ring (1/2 X 3/8 X 1/16)
8	15130	1	Plug (1/16 NPTF)
9	10265	1	O-ring (5/16 X 3/16 X 1/16)
10	45559	1	Block
11	305526	1	High Pressure Piston
12	45866	1	Block
13	12223	2	Ball (3/16 Dia.)
14	10445	2	Compression Spring (5/32 O.D. X 3/4 Lg.)
15	24549	2	Ball Guide
16	14763	1	O-ring (7/16 X 5/16 X 1/16)
17	13229	1	Elbow
18	250630	1	Drain Tube
19	251800	1	Elbow Fitting
20	304819	2	Hose Assembly



### HYDRAULIC SCHEMATIC

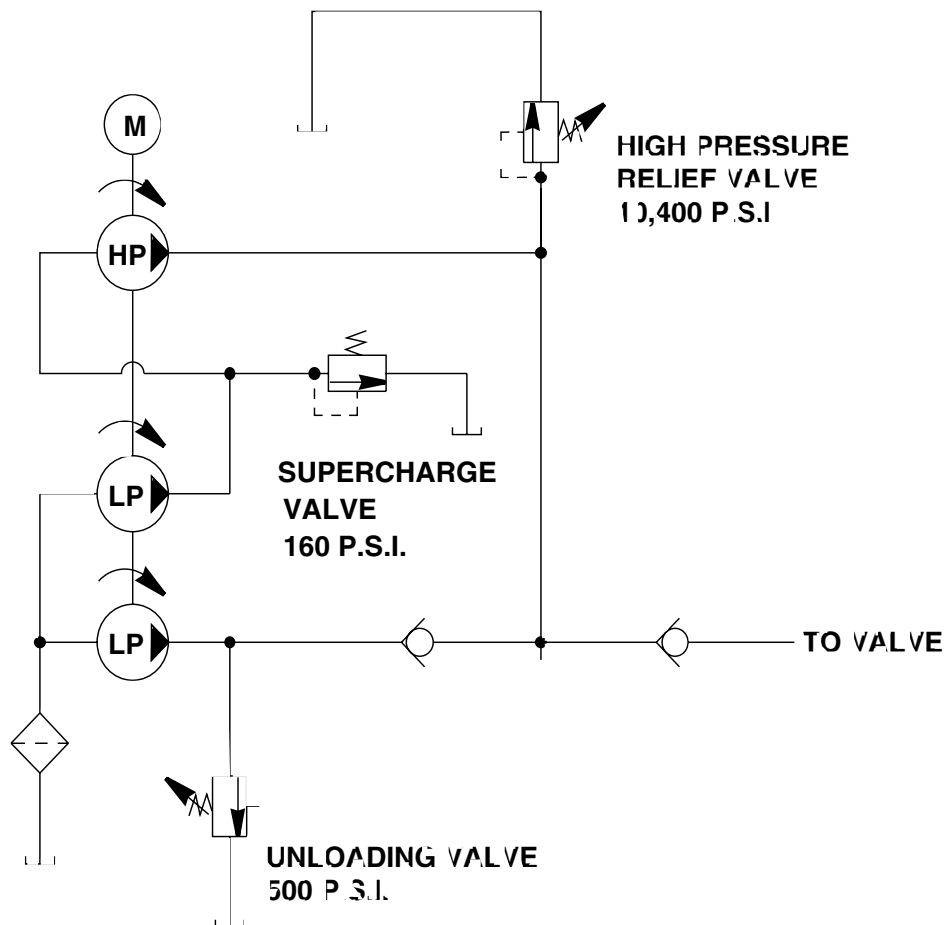

# MOTOR & CONTROL ASSEMBLY

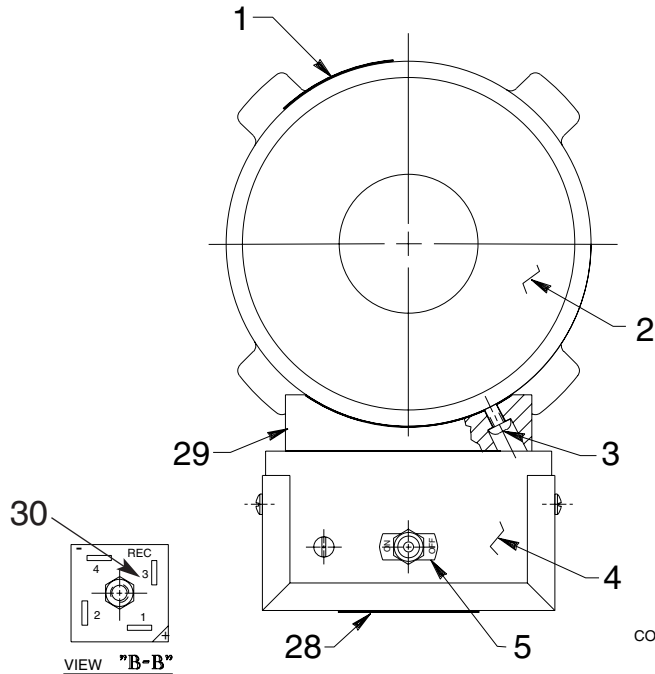

NOTE: RECTIFIER SUPPLIED WITH MOTOR.

VIEW "B-B"

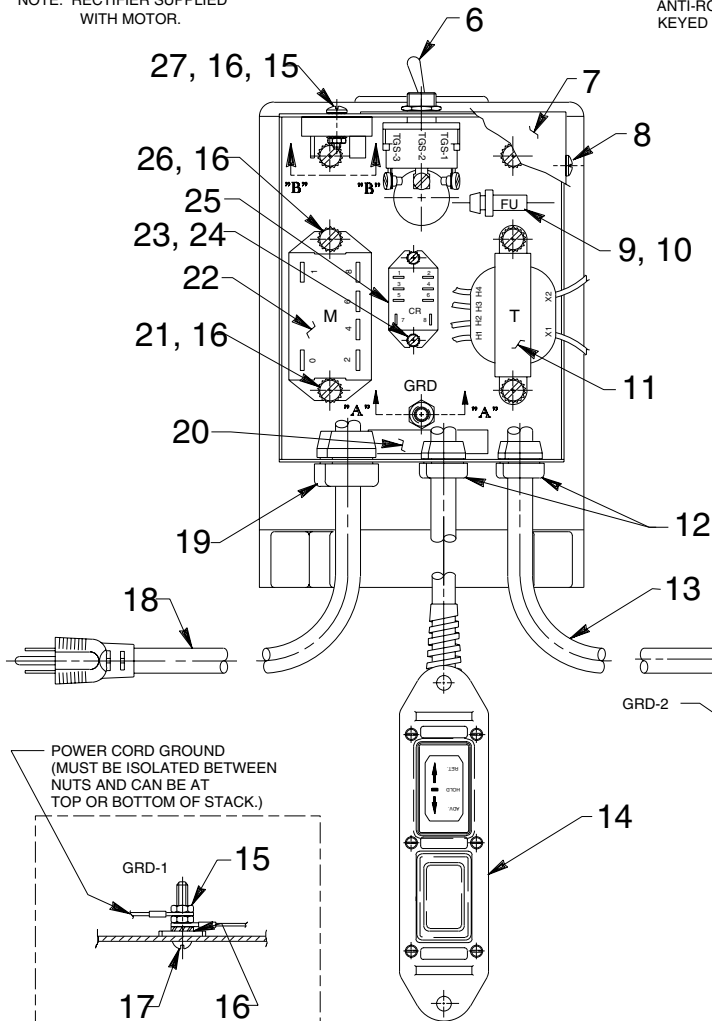
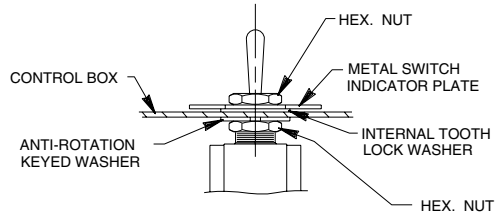

POWER CORD GROUND (MUST BE ISOLATED BETWEEN NUTS AND CAN BE AT TOP OR BOTTOM OF STACK.)

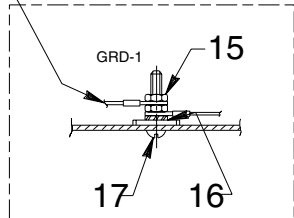

NOTE: SERRATED LOCK WASHER MUST BE ADJACENT TO METAL BOX. MORE WASHERS CAN BE USED IF DESIRED.

VIEW "A-A"

# Parts List, Form No. 101452, Back sheet 4 of 5

Item No.	Part No.	No. Req'd	Description	Item No.	Part No.	No. Req'd	Description
1	351024	1	Decal	15	10197	2	Nut (#10-24 UNC)
2	*420838BK2	1	Electric Motor (115 V.)	16	11108	14	Lockwasher (#10 External Tooth)
	**420839BK2	1	Electric Motor (220 V.)	17	11856	1	Machine Screw (#10-24 X 1" Lg.)
3	12316	2	Screw	18	308752	8 ft.	Elect. Cable (14/3 SJTO; For 220v.)
4	58558BK2	1	Electrical Control Box		25229	1	Cord Set (14/3 SJTO; For 115v.)
5	13890	1	Indicator Plate	19	210112	4	Strain Relief Bushing
6	12301	1	Toggle Switch	20	205189	1	Ground Decal
7	42576BK2	1	Control Box Cover	21	10164	2	Slotted Screw (#10-24 UNC X 3/8 Lg.)
8	11141	4	Screw (#6-20 X 3/8 Lg.)	22	251638	1	Relay
9	16887	1	Fuse Holder (For 220 v.)	23	10159	2	Machine Screw
	16887	2	Fuse Holder (For 220 v.)	24	15906	2	Lockwasher
10	252288	1	Fuse (15 AMP; For 115 v.)	25	251046	1	Relay
	250176	2	Fuse (6.25 AMP; For 220 v.)	26	12909	4	Machine Screw
11	251049	1	Transformer	27	10167	1	Machine Screw (10-24 UNC x 3/4 lg.)
12	15993	2	Strain Relief Bushing	28	200188	1	Decal
13	12293	30"	Electrical Cable	29	420962	1	Mounting Adapter
14	202778	1	Hand Switch Assembly (See sheet 5 of 5.)	30	251050	1	Rectifier

\* Note: For replacement brushes, order (2) #252958.

\*\* Note: For replacement brushes, order (2) #252961.

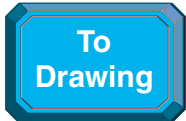

## ELECTRICAL SCHEMATIC



**WARNING:** To help avoid personal injury, all electrical work must be done by a qualified

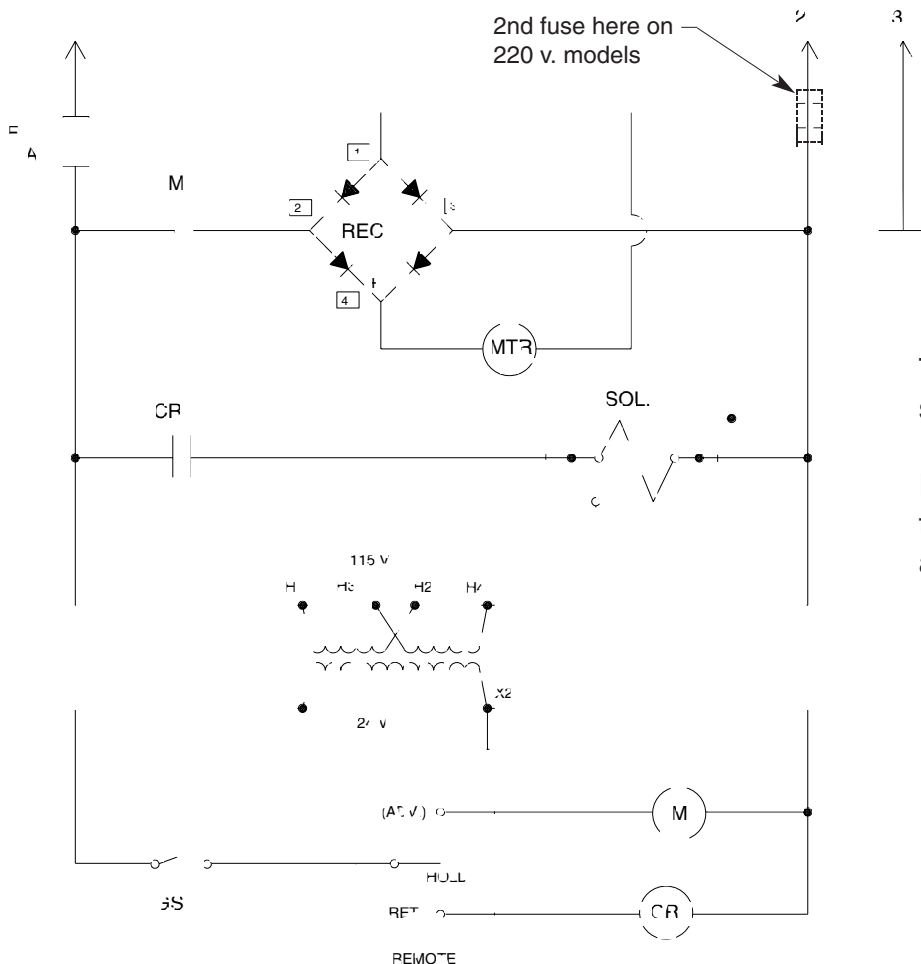

Transformer connections are as shown for 110/115v., 60 Hz.

For 220/230v., 50 Hz. units, transformer connections to be as follows:

- H1 to L1
- H2 to H3
- H4 to L2

Note: Shaded areas reflect last revision(s) made to this form.



# REMOTE HAND SWITCH ASSEMBLY

No. 202778

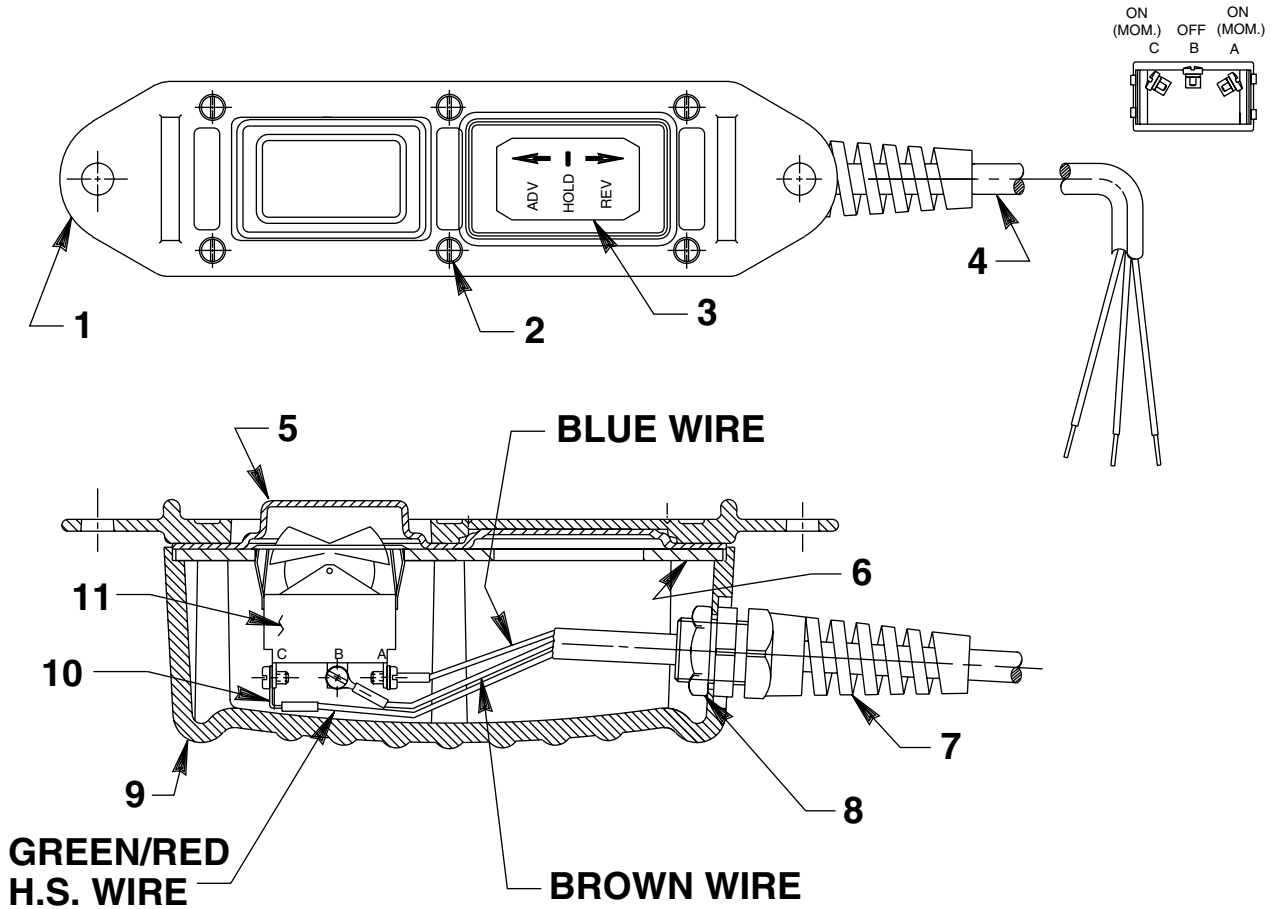

Item No.	Part No.	No. Req'd	Description
1	420050-1	1	Cover
2	250248	6	Screw (4-24 x 3/4 Lg.)
3	202776	1	Decal
4	12908	10 ft.	Cable (18/3 SJTO)
5	420050-2	1	Gasket
6	420050-3	1	Switch Mounting Plate
7	251818	1	Strain Relief Connector
8	251802	1	Locknut (3/4-16 UNF)
9	420050-4	1	Switch Housing
10	10525	3	Ring Tongue Terminal
11	16773	1	Rocker Switch