

MODEL A AIR/HYDRAULIC PUMP TUBE STYLE

To Parts List

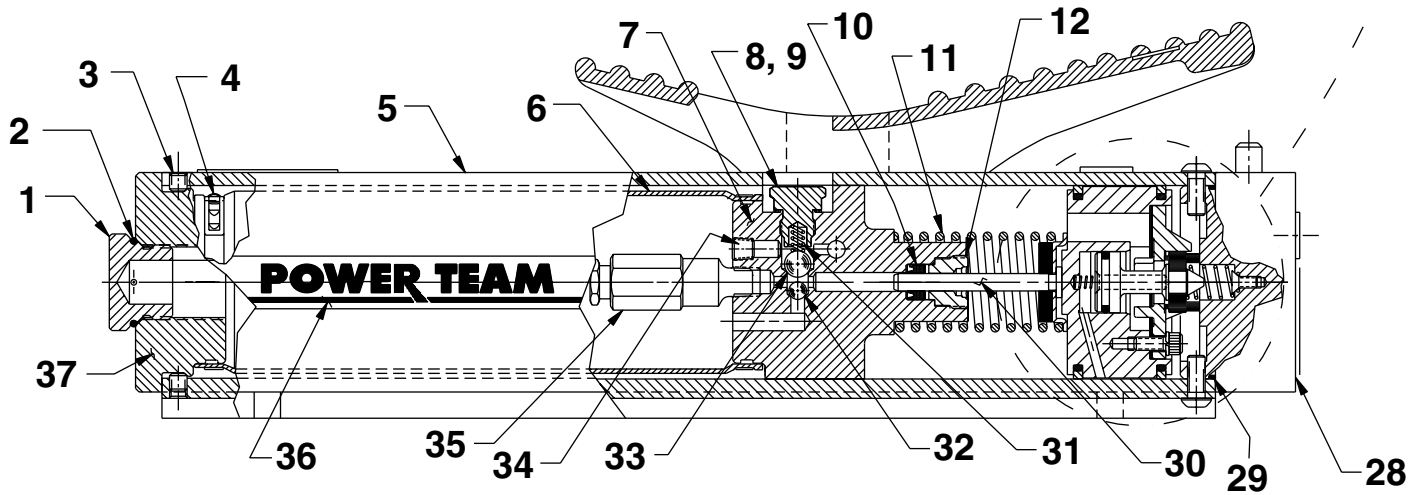

END VIEW

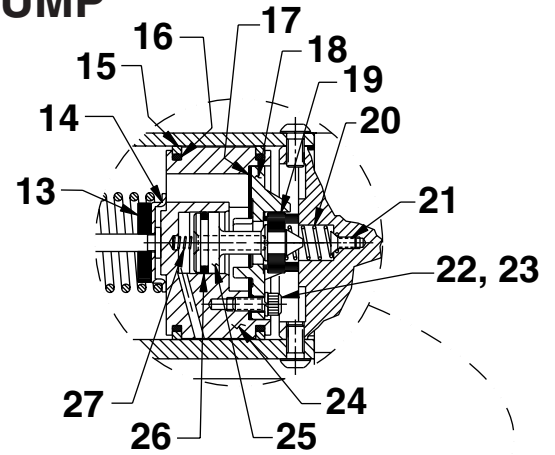
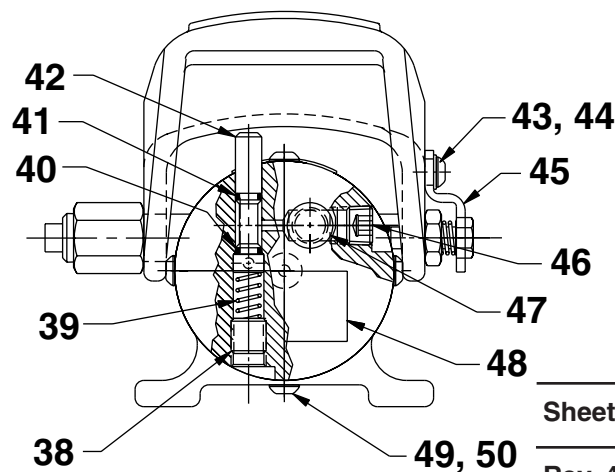

Parts List, Form No. 101730, Back sheet 1 of 2

Item No.	Part No.	No. Req'd	Description
1	252298	1	Filler Plug
2	*16684	1	O-ring (1.18 X 1.00)
3	10136	2	Hex Set Screw (1/4-20 X 1/4 Lg.)
4	*252303	2	Clamp
5	65307	1	Pump Housing
6	*421332	.50 ft.	Bladder
7	65308	1	Pump Body
8	305975	1	Valve Screw (1/2-20 X 7/8 Lg.; Torque to 380/400 in. lbs.)
9	*14874	1	Copper Washer (.70 X .50)
10	*13934	1	U-cup (.50 X .25 X .25H)
11	13938	1	Spring (1.45 O.D. X 4.4)
12	*304295	1	Retainer (NOTE: See "INSTRUCTIONS FOR RETAINER REPLACEMENT" on back sheet 2 of 2.)
13	*203143	1	Bumper
14	210994	1	Spring Guide
15	*14265	2	Piston Ring (2.77 X 2.54)
16	*251835	2	O-ring (2.31 X 2.12)
17	*28239	1	Gasket
18	33822	1	Piston End Plate Casting
19	*28183	1	Piston Poppet
20	*205679	1	Spring (.49 O.D. X .92)
21	205674	1	Flat Hd. Screw (8-32 X 3/8; Torque to 12/18 in. lbs.)
22	211054	3	Soc. Hd. Screw (10-24 X 1/2; Torque to 50/55 in. lbs.)
23	*10241	3	Lockwasher (.33 X .20)
24	52390	1	Piston Body
25	305475	1	Exhaust Valve Stem
26	*211052	1	O-ring (.90 X .70)
27	*12692	1	Spring (.18 O.D. X 1.70)
28	58838	1	Rear Head
29	*252349	1	O-ring (2.75 X 2.65)
30	28226	1	Piston (1/4")
31	*10444	1	Spring (.25 O.D. X .41)
32	*10375	1	Steel Ball (1/4" Dia.; Seat at assembly)
33	*10378	1	Steel Ball (3/8" Dia.; Seat at assembly)
34	11084	1	Plug Fitting (1/16 NPTF)
35	21278	1	Relief Valve (Set at 10,100 to 10,700 PSI)
36	351341	1	Trade Name Decal
37	351331	1	End Filler Cap
38	10566	1	Set Screw (1/2-13 X 1/2 Lg.; Note: Apply thread sealant.)
39	14484	1	Spring (.36 O.D. X 1.0)
40	*12522	1	O-ring (.37 X .25; Urethane)
41	*10266	1	O-ring (.37 X .25)
42	351330	1	Valve Stem
43	251437	1	Button Hd. Screw (1/4-20 X 1/2)
44	12719	1	Plain Washer (.63 X .29)
45	351371	1	Release Clip
46	10479	1	Plug Fitting (1/4 NPTF)
47	14794	1	Plastic Cap
48	14350	1	Caution Decal
49	15911	4	Button Hd. Screw (1/4-20 x 5/8; Torque to 60/80 in. lbs.)
50	*10442	4	Copper Washer (3/8 X 1/4 X 1/32)

Part numbers marked with an asterisk (*) are contained in Repair Kit No. 300919.

Note: Shaded areas reflect last revision(s) made to this form.





TOP VIEW

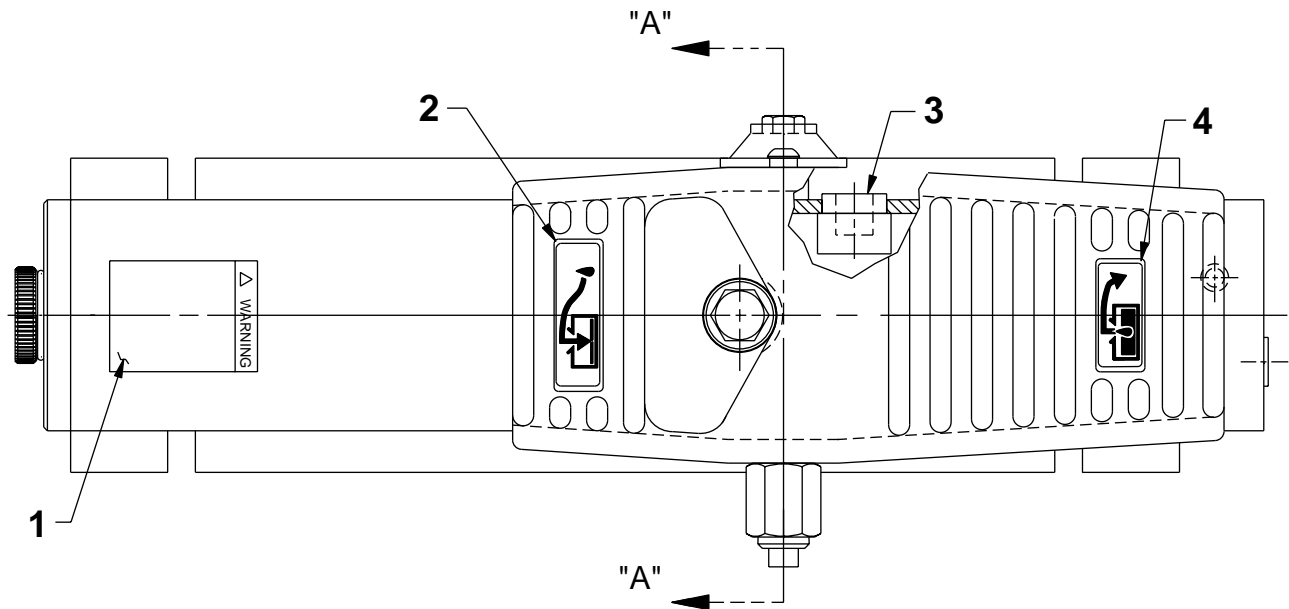

SECTION A-A

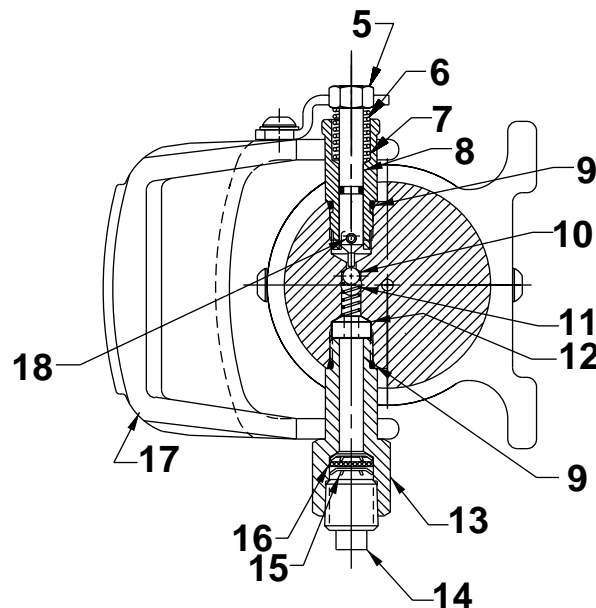

Item No.	Part No.	No. Req'd	Description
1	251762	1	Warning Decal
2	251758	1	Instruction Decal (Release)
3	*252300	2	Muffler
4	251757	1	Instruction Decal (Pump)
5	252526	1	Release Pin (Release stem must move freely through clip when assembled.)
6	14960	1	Spring (.49 O.D. X 1.0)
7	351413	1	Pivot Cam (Torque to 280/300 in. lbs.)
8	*10265	1	O-ring (.31 X .18)
9	*10300	2	O-ring (.62 X .46)
10	*10374	1	Steel Ball (7/32" Dia.; Seat at assembly)
11	*11024	1	Spring (.25 O.D. X .68)
12	252445	1	Bushing
13	351335	1	Pressure Port Fitting (Torque to 580 to 600 in. lbs.)
14	11127	1	Plug Fitting (3/8 NPTF)
15	*11088	2	Internal Retaining Ring (.31 X .010)
16	*250638	1	Oil Filter Disc
17	421371	1	Machine Foot Pedal
18	10796	1	Dowel Pin (.13 X .50)



Part numbers marked with an asterisk (*) are contained in Repair Kit No. 300919.

INSTRUCTIONS FOR RETAINER REPLACEMENT

Your pump's retainer is locked into place by one of the two following methods. Determine which method was used on your pump's retainer, then follow the appropriate steps to remove the old and install and stake the new.

Method 1 - Retainer shows no sign of stake marks

1. This retainer has been locked in place with a Loctite product. To replace it, a moderate amount of heat needs to be applied to the cylinder nut (in the area of the retainer) to soften the existing Loctite allowing it to be removed.
2. Install the new retainer into the cylinder nut and torque to 80/100 in. lbs. **Note: Do not use a Loctite product this time but stake the new retainer in place according to instructions in Step 3.**
3. To lock retainer into place, use a center punch positioned in the seam between the retainer and the cylinder nut and stake the new retainer in two places approximately 180° apart.

Method 2 - Retainer has two stake marks in the seam between the retainer and the cylinder nut

1. For replacement of this retainer, the stake marks must be removed. Using a 1/8" or larger diameter drill bit, remove the existing stakes by drilling a short distance into the stake marks. Remove the retainer.
2. Install the new retainer into the cylinder nut and torque to 80/100 in. lbs.
3. To lock retainer into place, use a center punch positioned in the seam between the retainer and the cylinder nut and stake the new retainer in two places approximately 180° apart.

NOTE: Do not stake in the old stake marks.

Note: "INSTRUCTIONS FOR RETAINER REPLACEMENT" added at last revision(s) made to this form.