

MODEL F AIR HYDRAULIC PUMP

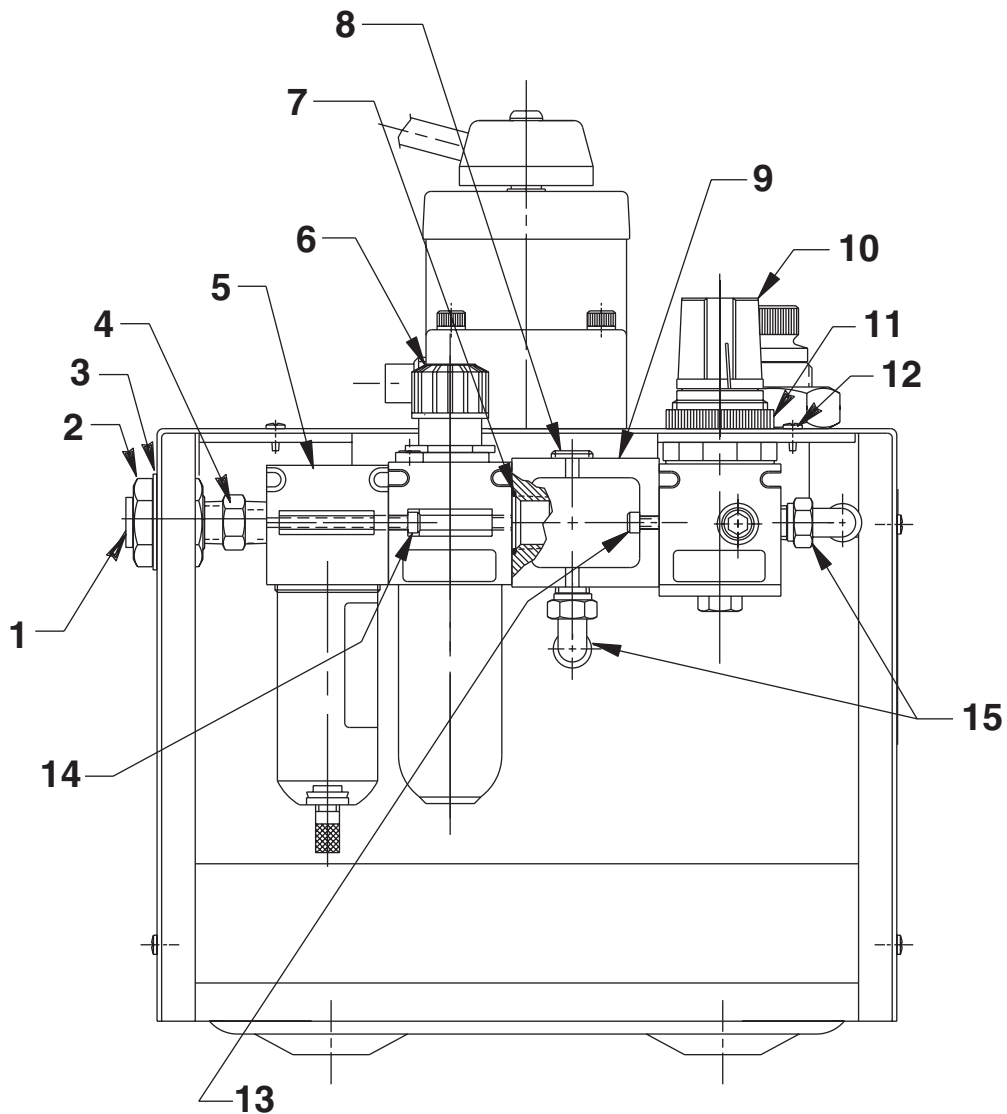

Parts List, Form No. 101694, Back sheet 1 of 5

Item No.	Part No.	No. Req'd	Description
1	13270	1	Plastic Cap
2	216671	1	Straight Fitting (1/4 NPTF)
3	12330	1	Plain Washer (1.48 X .82)
4	16494	1	Straight Fitting (1/4 NPTF)
5	351109	1	Filter Assembly (For replacement bowl order no. 251812; For replacement filter order no. *251811)
6	252030	1	Air Lubricator (For replacement bowl order no. 251813)
7	*10273	2	O-ring (.75 X .56; Included with connector block [Item #9])
8	10479	1	Pipe Plug (1/4 NPTF)
9	252031	1	Air Connector Block (Includes [2] of Item #7 and [6] of Item #13)
10	252033	1	Air Regulator
11	16614	1	Panel Nut (1-3/16-18)
12	14126	4	Pan Head Screw (10-24 x 3/8 Lg.)
13	10826	6	Cap Screw (#8-32 UNC X 1/2 Lg.; Included with connector block [Item #9])
14	252064	2	Hex Socket Screw (#8-32 x 1-3/4" Lg.)
15	15457	2	Fitting

PARTS INCLUDED BUT NOT SHOWN

309219CE 2 Trade Name Decal (For PA60 & PA64)

Part numbers marked with an asterisk (*) are contained in Repair Kit No. 300883.

Refer to any operating instructions included with this product for detailed information about operation, testing, disassembly, reassembly, and preventive maintenance.

Items found in this parts list have been carefully tested and selected. **Therefore: Use only genuine Power Team replacement parts!**

Additional questions can be directed to our Technical Services Department.

TOP VIEW

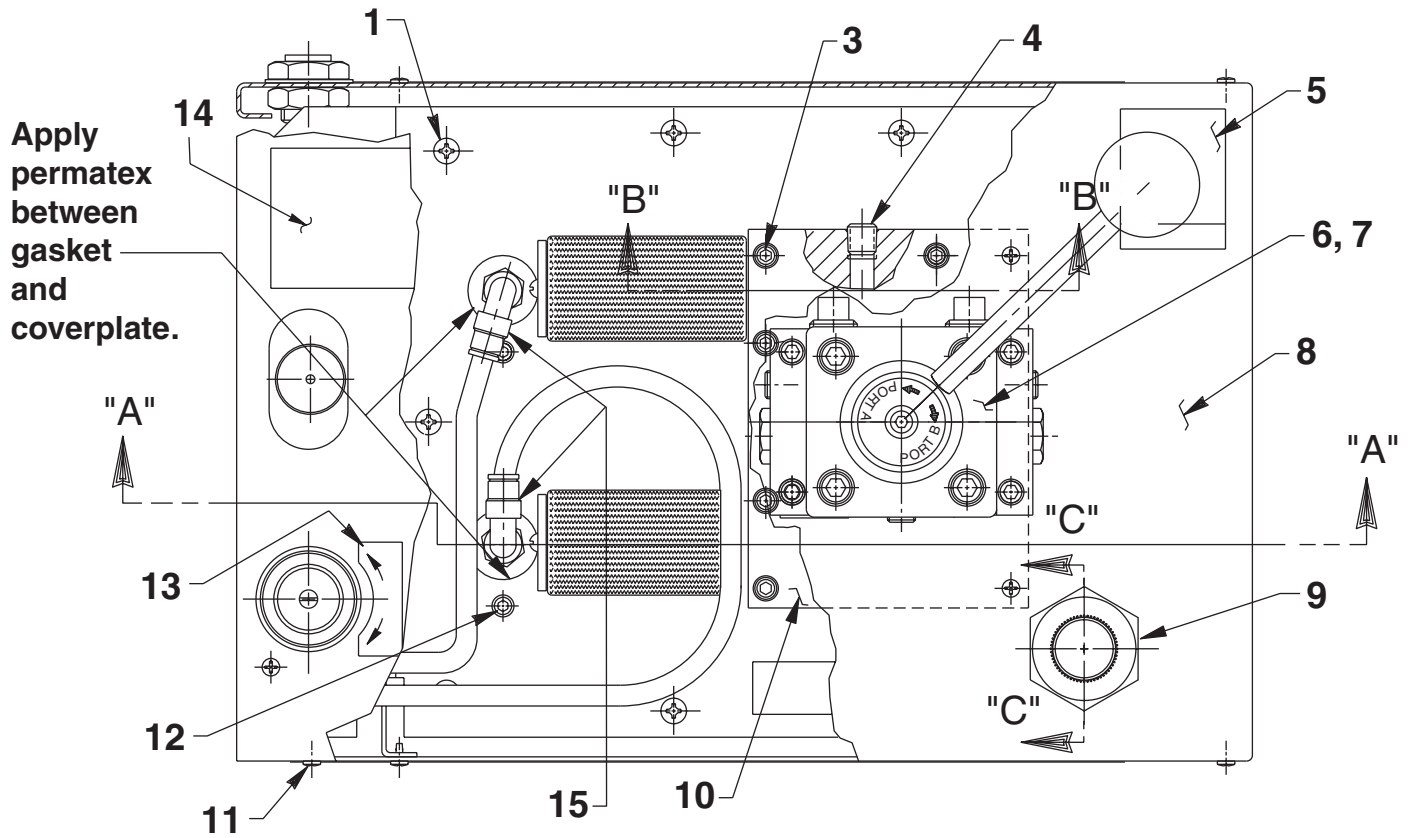

Item No.	Part No.	No. Req'd	Description
1	252168	14	Cap Screw (1/4-10 X 1" Lg. Self-tapping; Torque to 35/45 in. lbs.)
3	11151	8	Socket Hd. Screw (10-24 UNC X 1-1/4"; Torque to 50/60 in. lbs.)
4	10427	2	Pressure Plug (1/8 NPTF)
5	251762	1	Warning Decal
6	9507	1	Manual 4-way Closed Center Valve (For PA64 & PA64-WP; See form #100628)
7	10274	1	O-ring (.87 X .68; Located under valve.)
8	65062WH2	1	Top Cover
9	252042	1	Hex Jam Nut (1-14)
10	65071	1	Manifold Block
11	14126	6	Tapping Screw (10-24 X 3/8 Lg.)
12	11434	4	Cap Screw (10-24 UNC X 1/2; Torque to 50/60 in. lbs.)
13	202076	1	Decal (Increase/Decrease)
14	350492	1	Instructions Decal
15	15457	2	Fitting

1/4" PISTON BASIC PUMP ASSY.

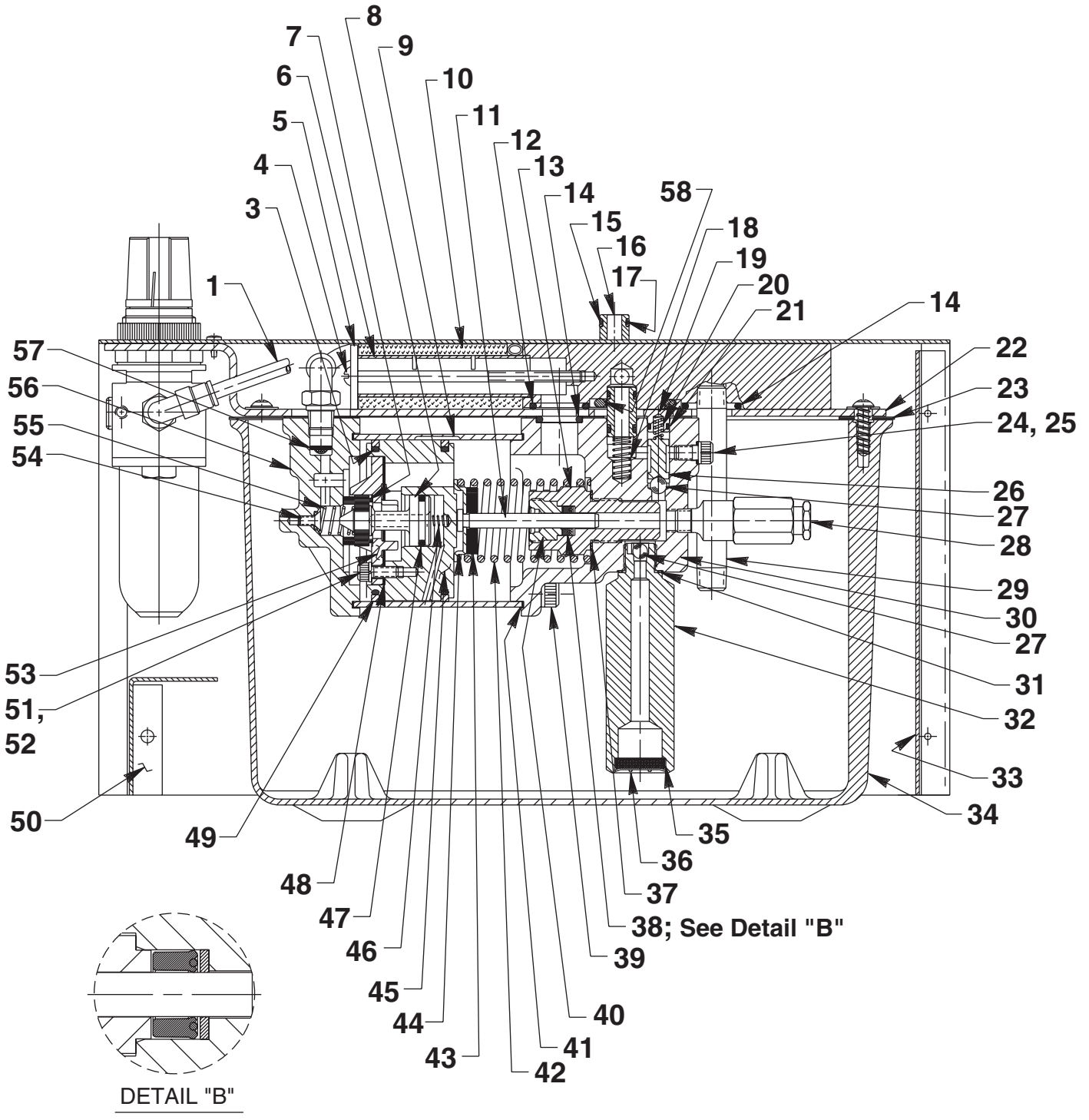

1/4" PISTON BASIC PUMP ASSY.

Item No.	Part No.	No. Req'd	Description	Item No.	Part No.	No. Req'd	Description
1	14726	2.2 Ft.	Tubing	32	48007	1	Filter Adapter (Torque to 35/40 ft. lbs., oiled)
3	*252348	4	O-ring (2.312" X 2.125" X .093; Nitrile)	33	42382WH2	1	Front Panel (For PA64-WP)
4	16453	2	Round Hd. Screw (#10-24 X 4; Note: Apply Loctite No. 277 to external threads.)		42382OR9	1	Front Panel (For PA60 & PA64)
5	16450	2	Special Washer (1.00 X .26)	34	61165	1	Reservoir
6	28387	2	Muffler	35	214578	1	Filter
7	*28183	2	Piston Poppet	36	214586	1	Internal Retaining Ring (.63 X .015)
8	305475	2	Exhaust Valve Stem	37	*10263	1	Special Washer (1.00 X .77)
9	37434	2	Air Cylinder (Note: Locate groove on upper half (top) of pump with chamfered tube end towards rear head (as shown).)	38	*13934	1	U-cup & Backup
10	*29992	2	Foam Tube	39	17428	1	Soc. Hd. Screw (1/4-20 X 3-1/2"; Torque to 85/95 in. lbs., oiled; Note: cross torque in increments of 30 in. lbs.)
11	28226	1	Piston (1/4")	40	*304295	1	Retainer (Note: See "INSTRUCTIONS FOR RETAINER REPLACEMENT" on back sheet 5 of 5.)
12	*10276	2	O-ring (1.00 X .75)	41	*17429	4	Backup Washer (2.94 X 2.75)
13	45278	1	Piston Cylinder (Torque to 90/100 ft. lbs., oiled)	42	*13938	1	Spring (1.452 O.D. X 4.4)
14	*10272	1	O-ring (.75 X .56)	43	203143	1	Bumper
15	10268	6	O-ring (.50 X .37)	44	210994	1	Spring Guide
16	21094	3	Bushing	45	52390	2	Piston Body
17	*11863	6	Backup Washer (.50 X .38)	46	*12692	2	Spring (.18 O.D. X 1.70)
18	*16448	1	Spring (.31 O.D. X .81)	47	*211052	2	O-ring (.90 X .70)
19	36497	2	Check Valve Retainer	48	*28239	2	Gasket
20	*10445	2	Spring (.16 O.D. X .72)	49	*252347	4	Piston Ring (2.77 X 2.54)
21	*12522	2	O-ring (.37 X .25; Urethane)	50	421211WH2	1	Back Panel (For PA64-WP)
22	65063WH2	1	Cover Plate		421211OR9	1	Back Panel (For PA60 & PA64)
23	*47409	1	Reservoir Gasket	51	211054	6	Screw (10-24 X 1/2; Torque to 50/55 in. lbs.)
24	10002	2	Socket Hd. Screw (1/4-20 X 3/8)	52	*10241	6	Lockwasher (.33 X .20)
25	*10442	2	Copper Washer (.37 X .25; Torque to 90/110 in. lbs.)	53	33822	2	Piston End Plate Casting
26	202568	2	Ball Guide	54	*205674	2	Flat Hd Screw (8-32 X 3/8; Torque to 12/18 in. lbs.)
27	*10423	2	Steel Ball (9/32" Dia.; Seat at ass'y.)	55	*205679	2	Compression Spring (.49 O.D. X .92)
28	21278	1	Relief Valve (Set at 10,100/10,700 PSI; Apply loctite 592 [Power Team #905516] or equiv. & torque to 150/170 in. lbs.; For PA60 & PA64)	56	37468	2	Rear Head
	21278-48	1	Relief Valve (Set at 4,900/5,300 PSI; Apply loctite 592 [Power Team #905516] or equiv. & torque to 150/170 in. lbs.; For PA64-WP only)	57	*216296	2	Filter Disc
29	15426	1	Straight Fitting (1/4 NPTF)	58	*11841	1	O-ring (1.62 x 1.37 Nitrile)
30	64767	1	Pump Body				
31	*10261	1	Copper Washer (.75 X .60)				

Part numbers marked with an asterisk (*) are contained in Repair Kit No. 300883.

Note: Shaded areas reflect last revision(s) made to this form.

Sheet No. 3 of 5

Rev 15 Date: 14 Nov 2005

3/4" PISTON BASIC ASSY. & DIPSTICK COMP.

SECTION "B-B"

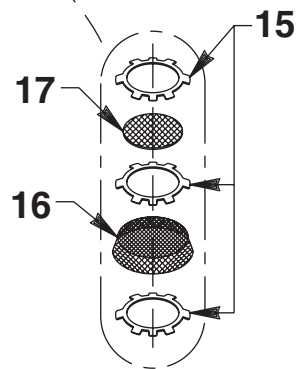
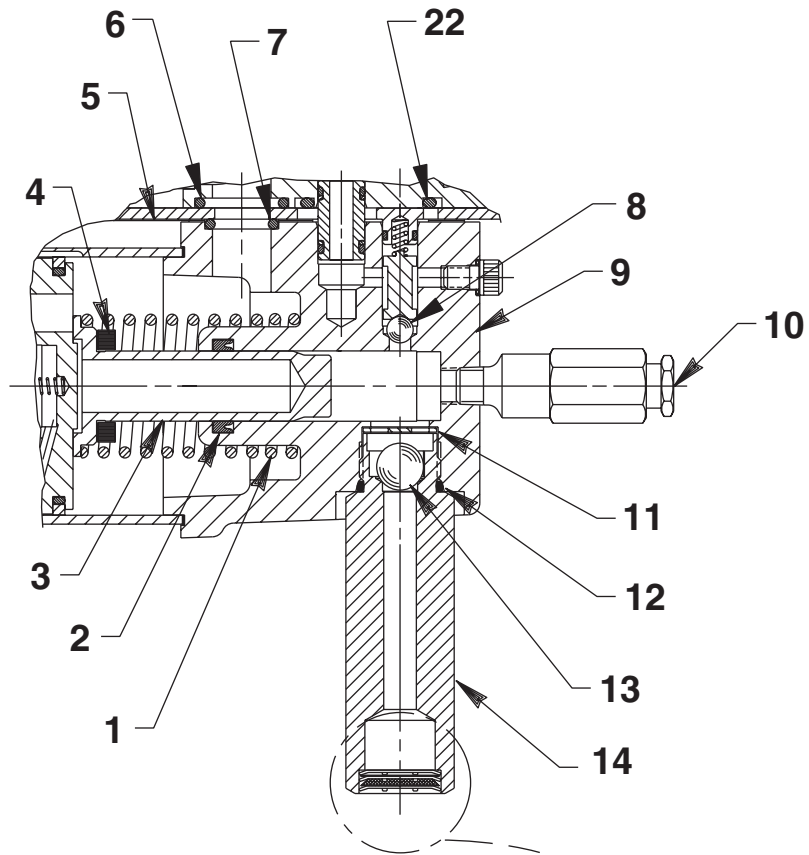

SECTION "C-C"

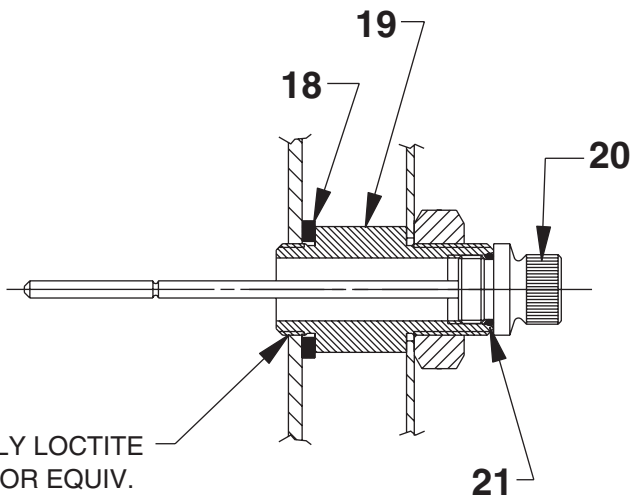

APPLY LOCTITE
277 OR EQUIV.

3/4" PISTON BASIC ASSY. & DIPSTICK COMP.

Item No.	Part No.	No. Req'd	Description
1	16584	1	Spring (1.6 O.D. X 4.55)
2	*16585	1	U-cup (1.00 X .75 X .19H)
3	305791	1	Piston
4	202566	1	Bumper
5	*351021	2	Cover Plate Gasket
6	*10276	1	O-ring (1.00 X .75)
7	*10272	1	O-ring (.75 X .56)
8	*10423	1	Steel Ball (9/32" Dia.)
9	58746	1	Pump Body
10	21278-15	1	Relief Valve (Set at 1,500/1,700 PSI; Apply loctite 592 [Power Team #905516] or equiv. & torque to 150/170 in. lbs.)
11	202347	1	Ball Stop
12	*10653	1	O-ring (.93 X .75)
13	*10379	1	Steel Ball (1/2" Dia.; Seat at ass'y.)
14	48009	1	Filter Adapter (Torque to 35/40 ft. lbs. oiled; See sheet 5 of 5)
15	214586	3	Internal Retaining Ring
16	214578	1	Filter
17	214595	1	Sintered Filter Screen
18	252041	1	Seal Washer (1.50 X 1.05)
19	351190	1	Filler Plug Adapter
20	251934	1	Dipstick
21	10527	1	O-ring (.81 X .64)
22	*11841	1	O-ring (1.62 x 1.37 Nitrile)

Part numbers marked with an asterisk (*) are contained in Repair Kit No. 300883.

**MANIFOLD ASSEMBLY
No. 9626
(For PA60 only)**

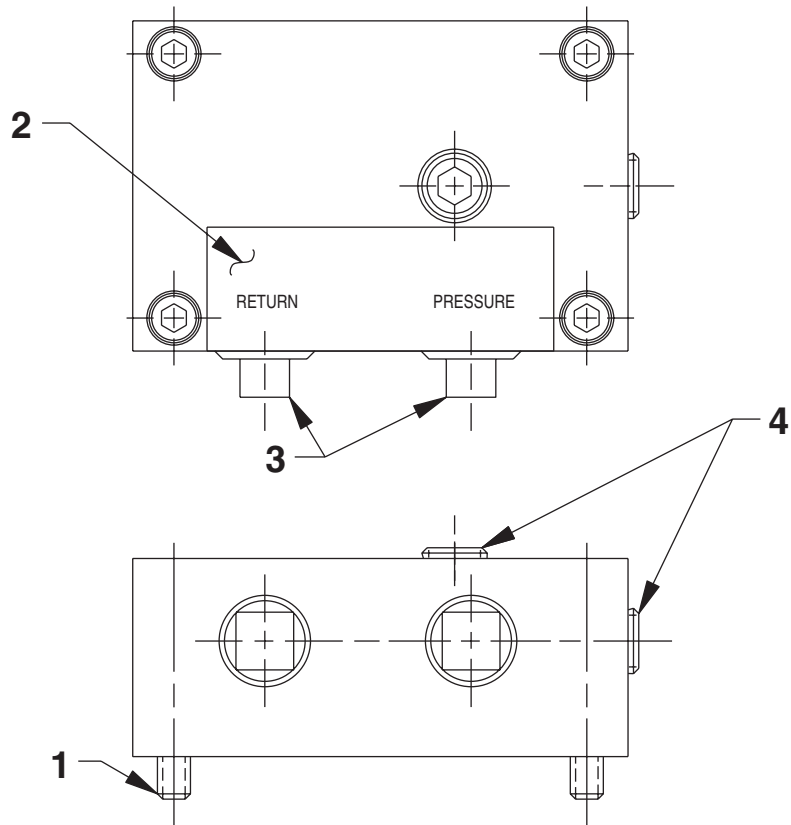

Item No.	Part No.	No. Req'd	Description
1	10022	4	Screw (1/4-20 X 1-1/2")
2	211167	1	Decal
3	11127	2	Plug Fitting (3/8 NPTF)
4	10479	2	Plug Fitting (1/4 NPTF)

**FILTER ADAPTER ASSEMBLY AFTER 6/1/98
For 2 Gallon Reservoir Only
(Reference Part Number 48007 & 48009)**

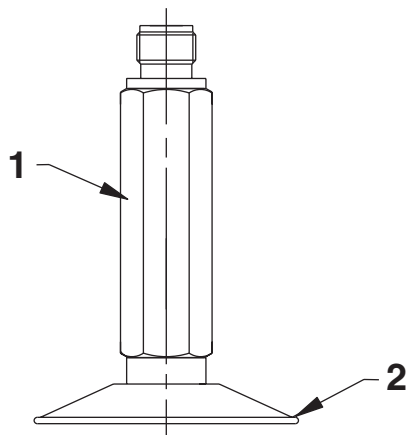

Item No.	Part No.	No. Req'd	Description
1	422016	1	Filter Adapter (For 48007)
	422018	1	Filter Adapter (For 48009)
3	29682	1	Filter

INSTRUCTIONS FOR RETAINER REPLACEMENT

Your pump's retainer is locked into place by one of the two following methods. Determine which method was used on your pump's retainer, then follow the appropriate steps to remove the old and install and stake the new.

Method 1 - Retainer shows no sign of stake marks

1. This retainer has been locked in place with a Loctite product. To replace it, a moderate amount of heat needs to be applied to the cylinder nut (in the area of the retainer) to soften the existing Loctite allowing it to be removed.
2. Install the new retainer into the cylinder nut and torque to 80/100 in. lbs. **Note: Do not use a Loctite product this time but stake the new retainer in place according to instructions in Step 3.**
3. To lock retainer into place, use a center punch positioned in the seam between the retainer and the cylinder nut and stake the new retainer in two places approximately 180° apart.

Method 2 - Retainer has two stake marks in the seam between the retainer and the cylinder nut

1. For replacement of this retainer, the stake marks must be removed. Using a 1/8" or larger diameter drill bit, remove the existing stakes by drilling a short distance into the stake marks. Remove the retainer.
2. Install the new retainer into the cylinder nut and torque to 80/100 in. lbs.
3. To lock retainer into place, use a center punch positioned in the seam between the retainer and the cylinder nut and stake the new retainer in two places approximately 180° apart.

NOTE: Do not stake in the old stake marks.

