

MODEL D TANDEM - TWO STAGE AIR HYDRAULIC PUMP Max. Capacity: 10,000 PSI

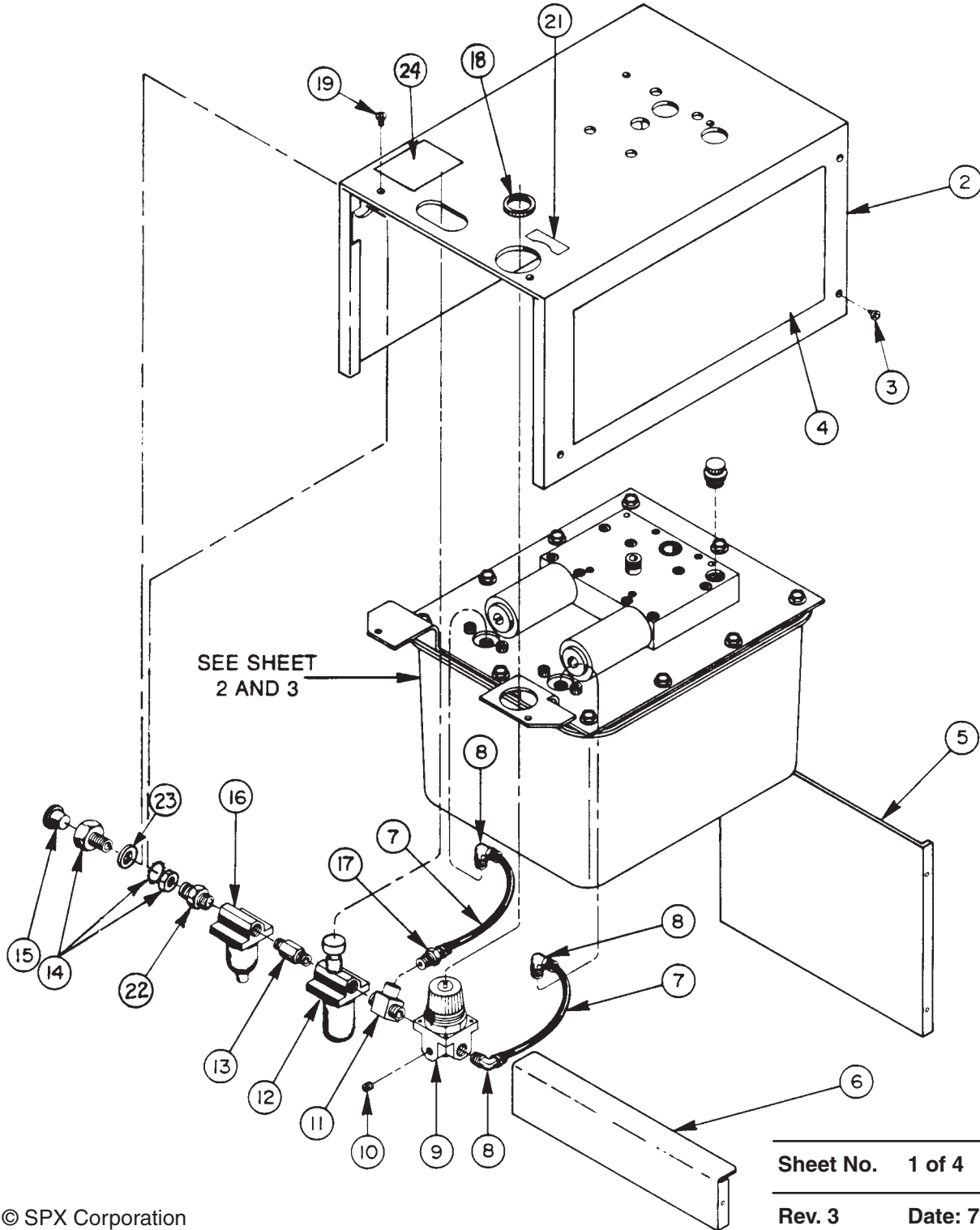

Parts List, Form No. 100618, Back sheet 1 of 4

Item No.	Part No.	No. Req'd	Description
2	60338WH2	1	Top Cover
3	14394	6	Self-tapping Screw (10-16 X 3/8 Lg.)
4	309219	2	Decal (Trade Name)
5	42382OR9	1	Front Panel
6	43481OR9	1	Back Panel
7	14726	2.2 ft.	1/4" Plastic Tubing
8	15457	3	Elbow
9	16492	1	Mini Air Regulator
10	10427	1	Plug
11	16495	1	Steel Tee
12	15009	1	Air Lubricator (Replacement bowl only - #206264; For Wilkerson model #251076; For Norgren model)
13	15024	1	Close Nipple
14	216671	1	Fitting
15	13270	1	Plastic Plug
16	15010	1	Air Filter (Replacement bowl only - #206265; For Wilkerson model #251082; For Norgren model)
17	250718	1	Connector Fitting
18	16614	1	Mounting Ring
19	14126	4	Thread Forming Screw
21	202076	1	Decal (Increase-Decrease)
22	16494	1	Hex Nipple
23	12330	1	Washer
24	350492	1	Important Decal

PARTS INCLUDED BUT NOT SHOWN

9507	1	4-Way Valve Assembly (Used on PA64 - See Form No. 100628)
9626	1	Manifold Assembly (Used on PA60 - See Form No. 100605)

Refer to any operating instructions included with this product for detailed information about operation, testing, disassembly, reassembly, and preventive maintenance.

Items found in this parts list have been carefully tested and selected. **Therefore: Use only genuine Power Team replacement parts!**

Additional questions can be directed to our Technical Services Department.

BASIC PUMP UNIT - ABOVE COVER PLATE

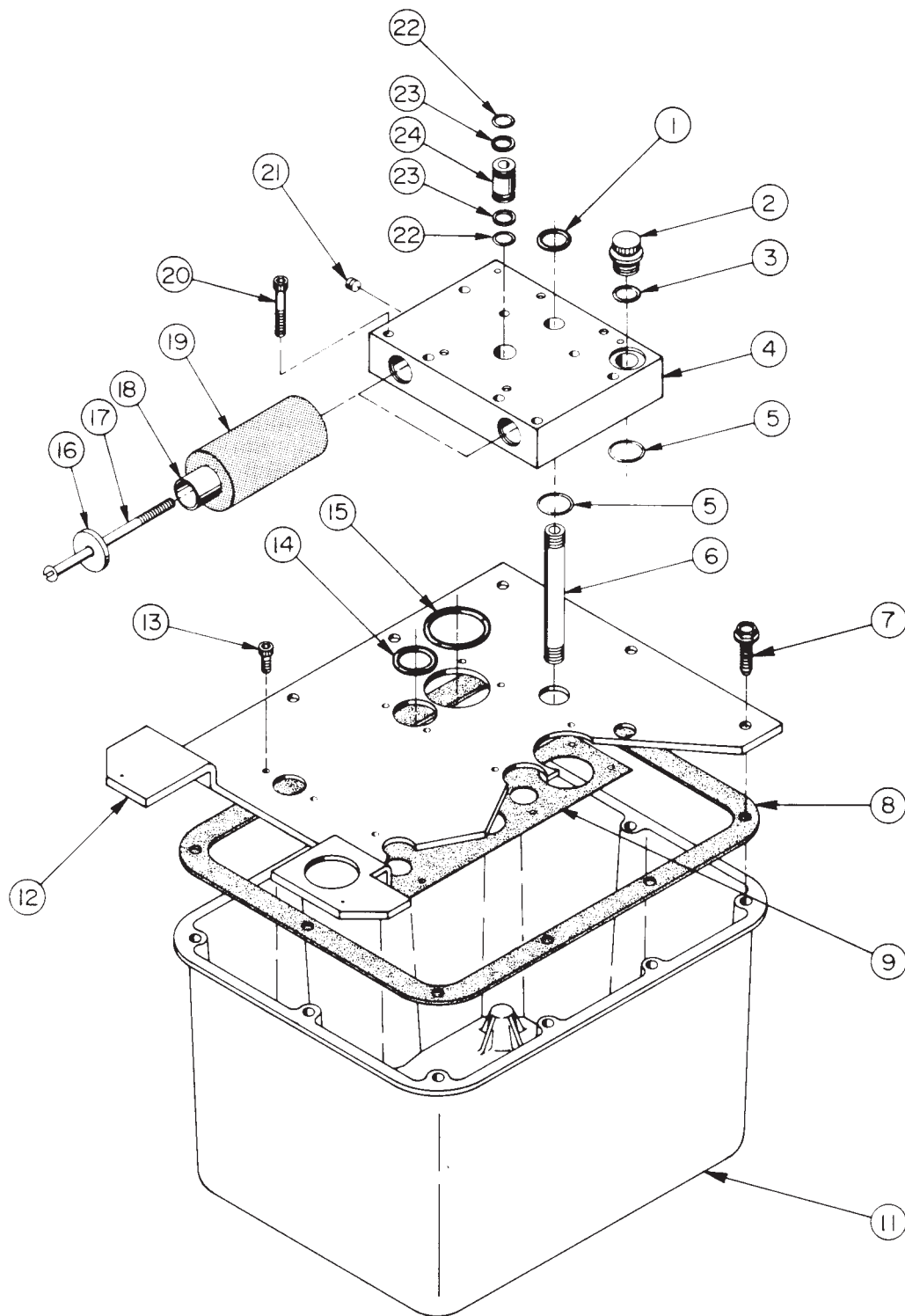

Parts List, Form No. 100618, Back sheet 2 of 4

Item No.	Part No.	No. Req'd	Description
1	*10274	1	O-ring (7/8 X 11/16 X 3/32)
2	24132S	1	Cap & Gasket Ass'y
4	60336	1	Port Block
5	*10304	2	O-ring (1" X 7/8 X 1/16)
6	15426	1	Drain Line
7	209799	14	Self-tapping Cap Screw (1/4-10 X 7/8 Lg.; Torque to 35/45 in. lbs.; Four used for Mtg.)
8	*47409	1	Cover Plate Gasket
9	*34283	2	Gasket
11	61165	1	Reservoir
12	50903WH2	1	Cover Plate
13	11434	4	Cap Screw (10-24 UNC X 1/2 Lg.; Torque to 50/60 in. lbs.)
14	*251214	2	O-ring (1.002 X .720 X .141)
15	*251215	2	O-ring (1.494 X 1.212 X .141)
16	16450	2	Steel Washer
17	16453	2	Rd. Hd. Screw (#10-24 UNC X 4" Lg.; Apply Loctite 277 or equivalent to external threads.)
18	28387	2	Muffler
19	*29992	2	Foam Tube
20	11151	8	Cap Screw (10-24 UNC X 1-1/4" Lg.; Torque to 50/60 in. lbs.)
21	10427	1	Plug
22	*10268	2	O-ring (1/2 X 3/8 X 1/16)
23	*11863	2	Backup Washer
24	21094	1	Bushing

Part numbers marked with an asterisk (*) are contained in Repair Kit No. 300447.

BASIC PUMP UNIT - BELOW COVER PLATE

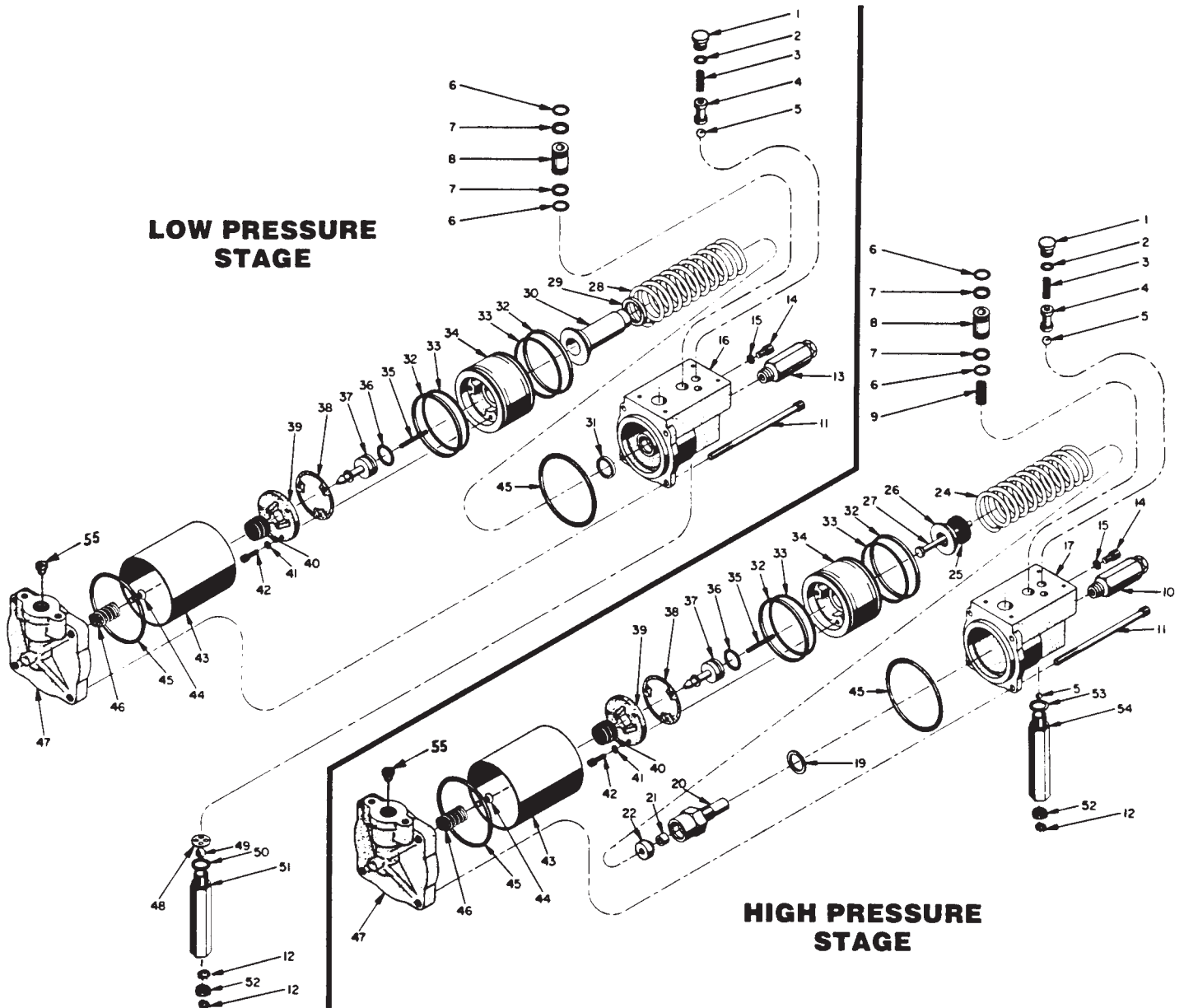

Parts List, Form No. 100618, Back sheet 3 of 4

Item No.	Part No.	No. Req'd	Description	Item No.	Part No.	No. Req'd	Description
1	36497	2	Check Valve Body	27	28226	1	Piston
2	*12522	2	O-ring (3/8 X 1/4 X 1/16)	28	*16584	1	Compression Spring (1-5/8" O.D. X 4-1/2" Lg.)
3	*10445	2	Compression Spring (5/32 O.D. X 3/4 Lg.)	29	*202566	1	Bumper
4	202568	2	Ball Guide	30	305791	1	Piston
5	*10423	3	Steel Ball (9/32 Dia.)	31	*16585	1	U-cup
6	*10268	4	O-ring (1/2 X 3/8 X 1/16)	32	*14265	4	Piston Ring
7	*11863	4	Backup Washer (1/2 X 3/8 X 1/16)	33	*251835	4	O-ring (2-1/2" X 2-5/16" X 3/32)
8	21094	2	Bushing	34	52390	2	Piston Body
9	*16448	1	Compression Spring (5/16 O.D. X 13/16 Lg.)	35	*12692	2	Spring
10	21278	1	Relief Valve Ass'y (Set at 10,100/10,700 PSI)	36	*211052	2	O-ring (.900 X .706 X .097)
11	17428	8	Cap Screw (1/4-20 UNC X 3-1/2" Lg.; Torque to 85/95 in. lbs. oiled. NOTE: Cross torque in increments of 30 in. lbs.)	37	305475	2	Exhaust Valve Stem
12	214586	3	Retaining Ring (Internal)	38	*28239	2	Gasket
13	21278-15	1	Relief Valve Assembly (Set at 1,500/1,700 PSI)	39	33822	2	Piston End Plate
14	10002	2	Cap Screw (1/4-20 UNC X 3/8 Lg.; Torque to 90/110 in. lbs.)	40	*28183	2	Piston Poppet
15	*10442	2	Copper Washer (3/8 X 1/4 X 1/32)	41	10241	6	Lockwasher
16	50916	1	Pump Body	42	211054	6	Cap Screw (#10-24 X 1/2 Lg.; Torque to 50/55 in. lbs.)
17	50494	1	Pump Body	43	37434	2	Air Cylinder (Locate groove on upper half of pump.)
19	*10263	1	Copper Washer (1" X .765 X 1/32)	44	*205674	2	Machine Screw (8-32 UNC X 3/8 Lg.; Torque to 12/18 in. lbs.)
20	45278	1	Cylinder (Torque to 90/100 ft. lbs.)	45	*17429	4	Backup Ring
21	*13934	1	U-cup	46	*205679	2	Spring
22	*304295	1	Retainer Nut (Note: See "INSTRUCTIONS FOR RETAINER REPLACEMENT" on sheet 4 of 4.)	47	37468	2	Rear Head
24	*13938	1	Compression spring (1.452 O.D. X 4-7/16" Lg.)	48	*202347	1	Ball Stop
25	*203143	1	Bumper	49	*10379	1	Steel Ball (1/2 Dia.)
26	210994	1	Spring Guide	50	*10653	1	O-ring (.949 X .755 X .097)
				51	48009	1	Intake Extension (Torque to 35/40 ft. lbs. oiled)
				52	214578	2	Filter
				53	*10261	1	Copper Washer (3/4 X 19/32 X 1/32)
				54	48008	1	Intake Extension (Torque to 35/40 ft. lbs. oiled.)
				55	*216296	2	Filter Disc

Part numbers marked with an asterisk (*) are contained in Repair Kit No. 300447.

Note: Shaded areas reflect last revision(s) made to this form.

INSTRUCTIONS FOR RETAINER REPLACEMENT

Your pump's retainer is locked into place by one of the two following methods. Determine which method was used on your pump's retainer, then follow the appropriate steps to remove the old and install and stake the new.

Method 1 - Retainer shows no sign of stake marks

1. This retainer has been locked in place with a Loctite product. To replace it, a moderate amount of heat needs to be applied to the cylinder nut (in the area of the retainer) to soften the existing Loctite allowing it to be removed.
2. Install the new retainer into the cylinder nut and torque to 80/100 in. lbs. **Note: Do not use a Loctite product this time but stake the new retainer in place according to instructions in Step 3.**
3. To lock retainer into place, use a center punch positioned in the seam between the retainer and the cylinder nut and stake the new retainer in two places approximately 180° apart.

Method 2 - Retainer has two stake marks in the seam between the retainer and the cylinder nut

1. For replacement of this retainer, the stake marks must be removed. Using a 1/8" or larger diameter drill bit, remove the existing stakes by drilling a short distance into the stake marks. Remove the retainer.
2. Install the new retainer into the cylinder nut and torque to 80/100 in. lbs.
3. To lock retainer into place, use a center punch positioned in the seam between the retainer and the cylinder nut and stake the new retainer in two places approximately 180° apart.

NOTE: Do not stake in the old stake marks.

Note: This page added at last revision(s) made to this form.