

**MODEL B
GAS HYDRAULIC PUMP**

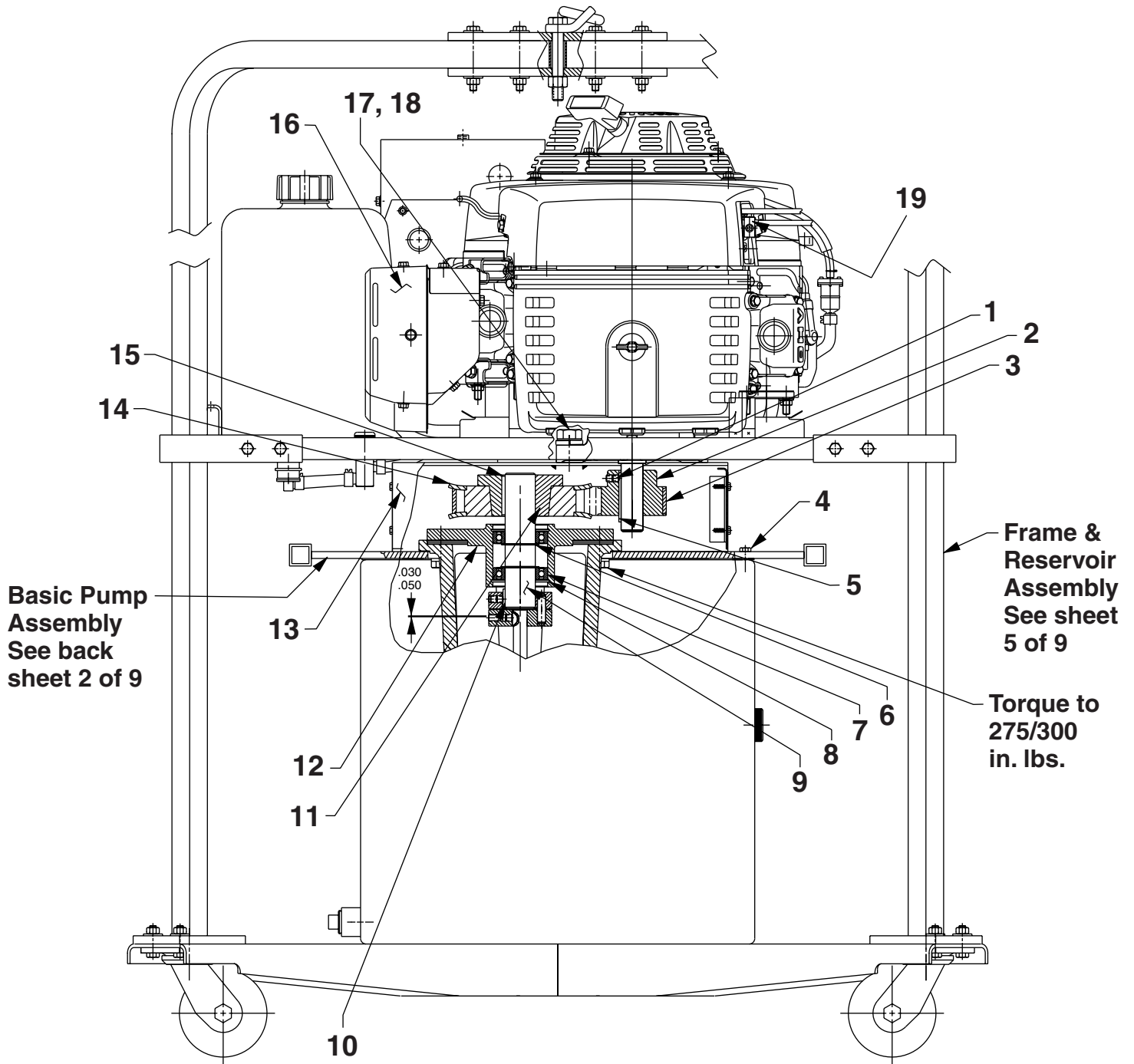

Item No.	Part No.	No. Req'd	Description
1	10141	2	Screw, Hex Set (5/16-18 x 5/16)
2	307257	1	Pulley
3	17590	1	Belt, Timing
4	15273	6	Screw, Flg Hx Hd (5/16-18 x 1/2)
5	203784	1	Key
6	11580	2	Ring, Retain Ext (1.27 x .050)
7	17597	2	Bearing, Ball
8	14366	2	Ring, Retain Int (2.50 x .078)
9	37621	1	Shaft
10	203731	1	Key
11	17593	1	Bushing, Drive
12	42877	1	Support, Shaft
13	60435WH2	1	Housing, Engine
14	17592	1	Pulley, Timing Belt
15	203730	1	Key
16	253601	1	Muffler, Exhaust
17	10035	4	Screw, HH Cap (5/16-18 x 1-1/2)
18	10246	4	Washer, Lock (.59 x .32)
19	253587	1	Bracket, Clamp

PARTS INCLUDED BUT NOT SHOWN

214205	1	Box, Battery
351454	1	Remote Hand Control Assembly

(For PG4004S; See sheet 9 of 9)

HYDRAULIC SCHEMATIC

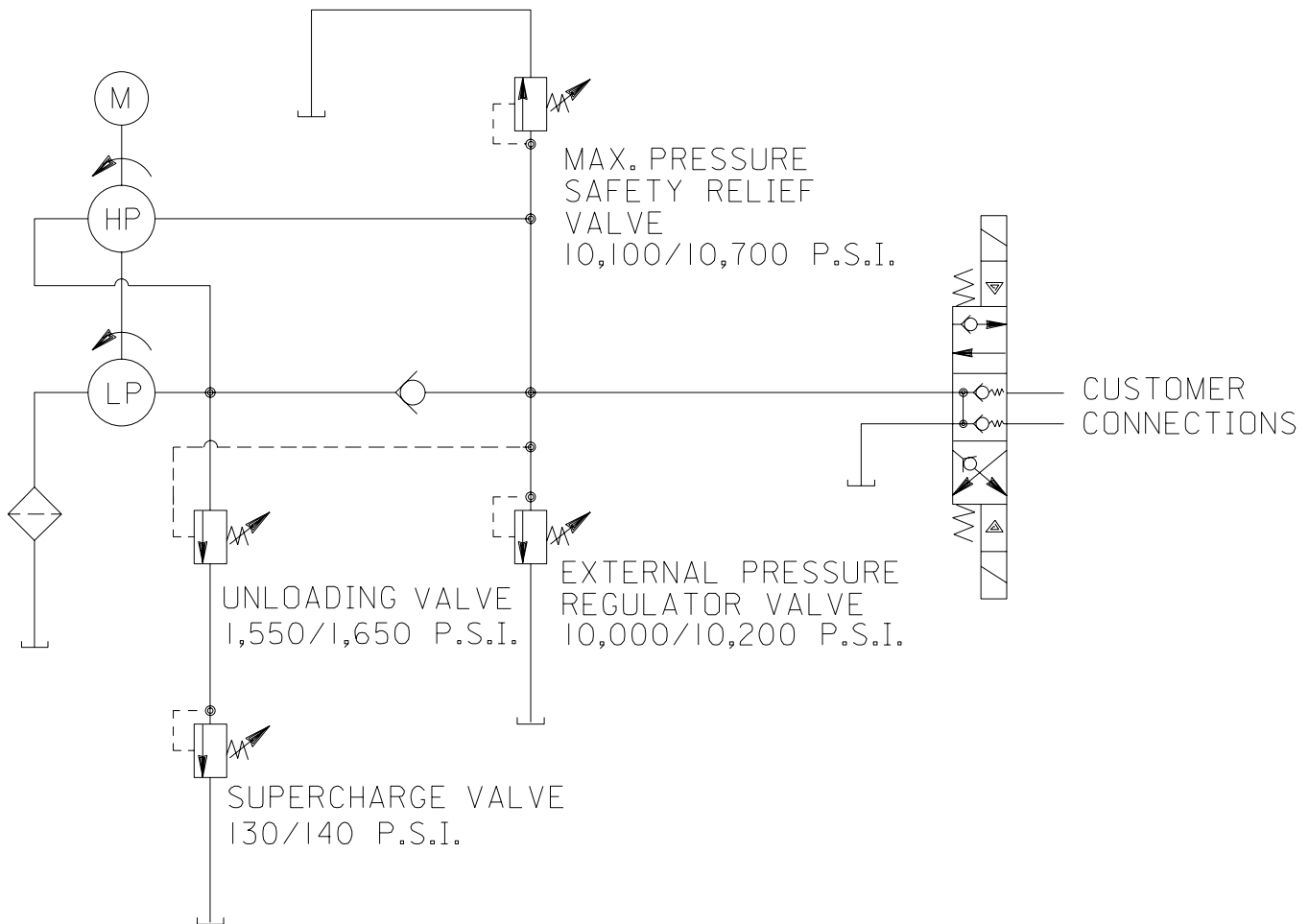

PUMP TOP VIEW

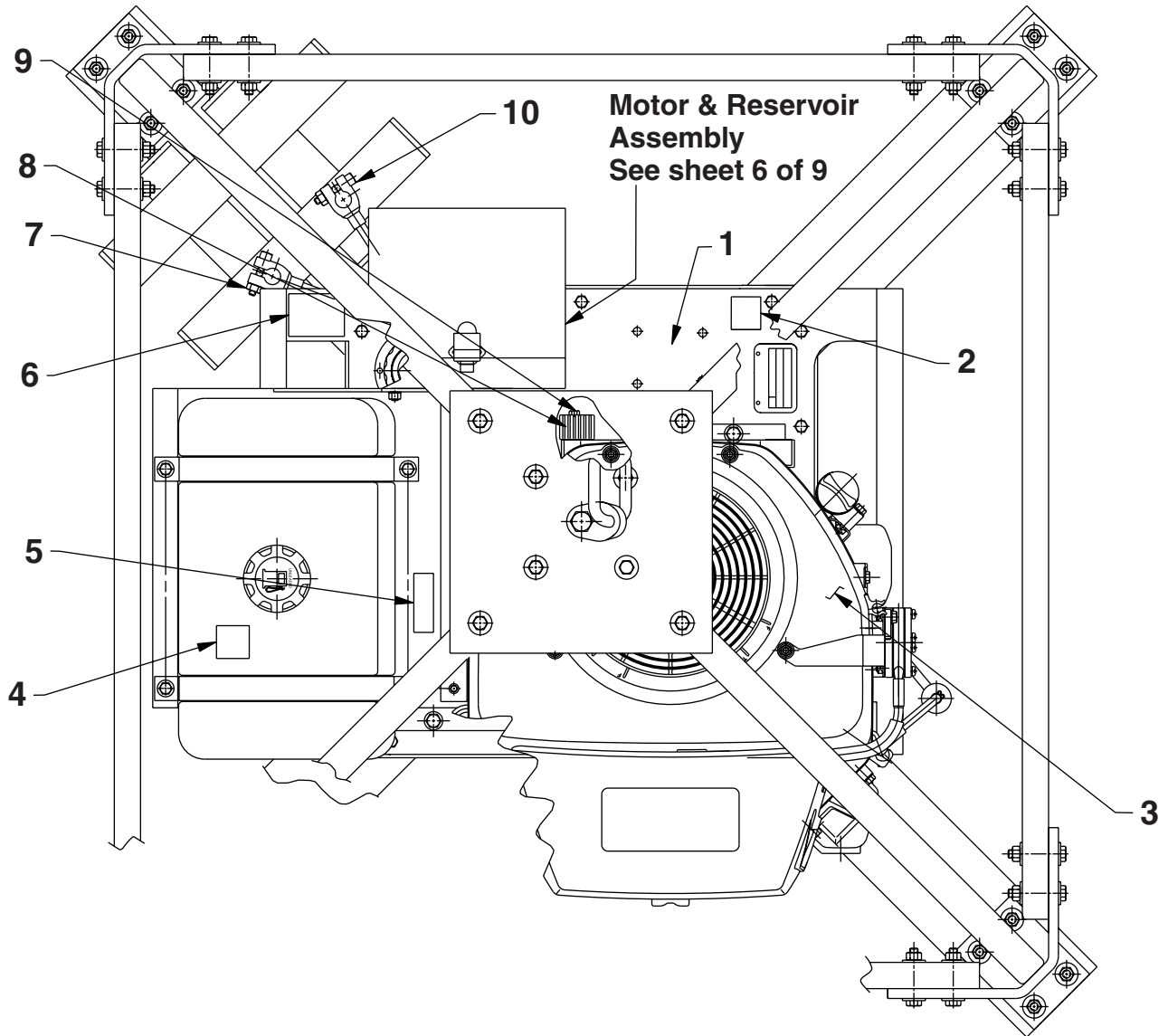

Item No.	Part No.	No. Req'd	Description
1	9506	1	Valve, Manual 4 way tandem ctr (For PG4004; See Form No. 100628)
	9513	1	Valve, Solenoid 4 way (For PG4004-HONDA, PG4004S & PG4004-BAR; See Form No. 101653)
2	205112	1	Decal, Patent
3	66195	1	Engine, Gas
4	203865	1	Decal, Warning
5	203866	2	Decal, Warning
6	203755	1	Decal, Instructions
7	213259	1	Cable, Battery
8	253603	1	Rectifier
9	253602	1	Bolt
10	213258	1	Cable, Battery

PARTS INCLUDED BUT NOT SHOWN

200395	1	Gasket (Between valve and pump cover plate.)
251957	1	Trade Name Decal (on valve)

BASIC PUMP ASSEMBLY SIDE VIEW

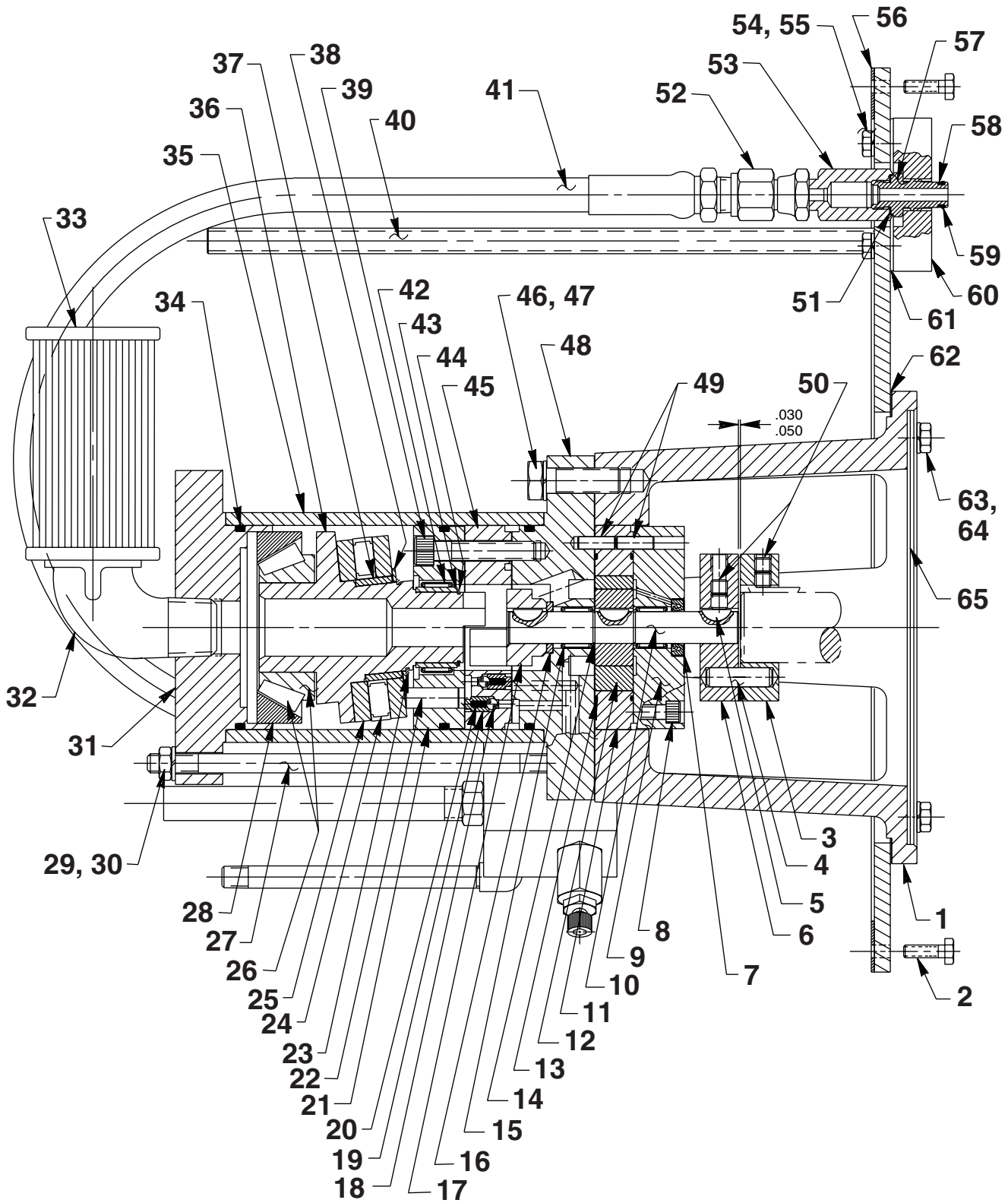

SECTION "A"- "A"

Item No.	Part No.	No. Req'd	Description	Item No.	Part No.	No. Req'd	Description
1	51089	1	Mounting Bracket	35	37384	1	Pump Housing
2	10009	20	Hex Hd. Cap Screw (1/4-20 x 3/4 Lg.)	36	51059	1	Angle Plate
3	37387	1	Coupling	37	203476	1	Bushing
4	203485	2	Nylon Pin	38	17566	1	Special Washer (Steel; 2-1/4 x 1.765 x 1/16 thk.)
5	204537	3	Woodruff Key (1/8 x 5/8)	39	12866	8	Soc. Hd. Cap Screw (3/8-16 UNC x 2-1/4" Lg.; Cross torque in increments of 100 in. lbs. to 460/480 in. lbs.)
6	37386	1	Coupling	40	204265	1	Drain Tube
7	12194	1	Oil Seal Packing (1-1/8 x 5/8)	41	303838	1	Hydraulic Hose (3/8 I.D. x 27" Lg.; For PG4004 & PG4004S)
8	10854	6	Soc. Hd. Cap Screw (1/4-20 x 1-3/4 Lg.; Cross torque to 80/100 in. lbs.)		351316	1	Hydraulic Hose (3/8 I.D. x 27" Lg.; For PG4004-HONDA & PG4004-BAR)
9	51064	1	Front End Plate	42	17505	1	Needle Bearing
10	37376	1	Pump Shaft	43	17504	1	Race Bearing
11	42782	1	Eccentric (Ring)	44	17312	1	Retainer Ring (External; 1-3/8 Lg.)
12	17313	1	Gerotor Set	45	42732	1	Valve Head
13	17315	2	O-ring (2-7/8 x 2-3/4 x 1/16)	46	10083	4	Hex Hd. Cap Screw (1/2-13 x 1-1/2 Lg.; Torque to 80/100 in. lbs.)
14	12178	2	Retainer Ring (External; 5/8 shaft)	47	10249	4	Spring Lockwasher (1/2)
15	15430	2	Needle Bearing (5/8 x 13/16 x 5/8 w.)	48	60415	1	Pump End Plate
16	17435	1	Thrust Washer (1" x 5/8 x 1/8)	49	17567	4	Spring Pin (1/4 x 3/4 Lg.)
17	37378	1	Drive Coupling	50	10141	4	Set Screw (5/16-18 x 5/16 Lg.)
18	10374	16	Steel Ball (7/32 dia.)	51	10261	1	Soft Copper Washer
19	203477	16	Ball Guide	52	17582	1	Swivel Fitting
20	17319	16	Compression Spring (1/8 O.D. x 1/2 Lg.)	53	21566	1	Valve Body
21	43313	1	Pump Barrel	54	10009	4	Hex. Hd. Cap Screw (1/4-20 x 3/4 Lg.)
22	204578	8	Piston (.399 dia.; NOTE: Install piston with 6° angle toward angle plate.)	55	10245	4	Spring Lockwasher (1/4)
23	14368	1	Retainer Ring (External; 1-3/4 shaft)	56	42779	1	Reservoir Gasket
24	17317	1	Thrust Bearing	57	201817	1	Valve Connector
25	17316	2	Race Bearing	58	11863	1	Backup Washer (Teflon)
26	17311	1	Cone Bearing	59	10268	1	O-ring (1/2 x 3/8 x 1/16)
27	203542	4	Tie Rod	60	43110	1	Valve Mounting Block
28	17318	1	Race Bearing (Cup)	61	200395	1	Gasket
29	10204	4	Steel Nut (3/8-16; Cross torque in increments of 50 in. lbs. to 170/180 in. lbs.)	62	42796	1	Gasket (Mounting Bracket)
30	10247	4	Spring Lockwasher (3/8)	63	10032	4	Hex. Hd. Cap Screw (5/16-18 x 1" Lg.)
31	42737	1	End Cap	64	10246	4	Spring Lockwasher (5/16)
32	10706	1	90° Pipe Elbow	65	42757	1	Gasket (Electric Motor)
33	17491	1	Filter				
34	11931	3	O-ring (4.00 x 3.75 Nitrile)				

BASIC PUMP ASSEMBLY BOTTOM VIEW

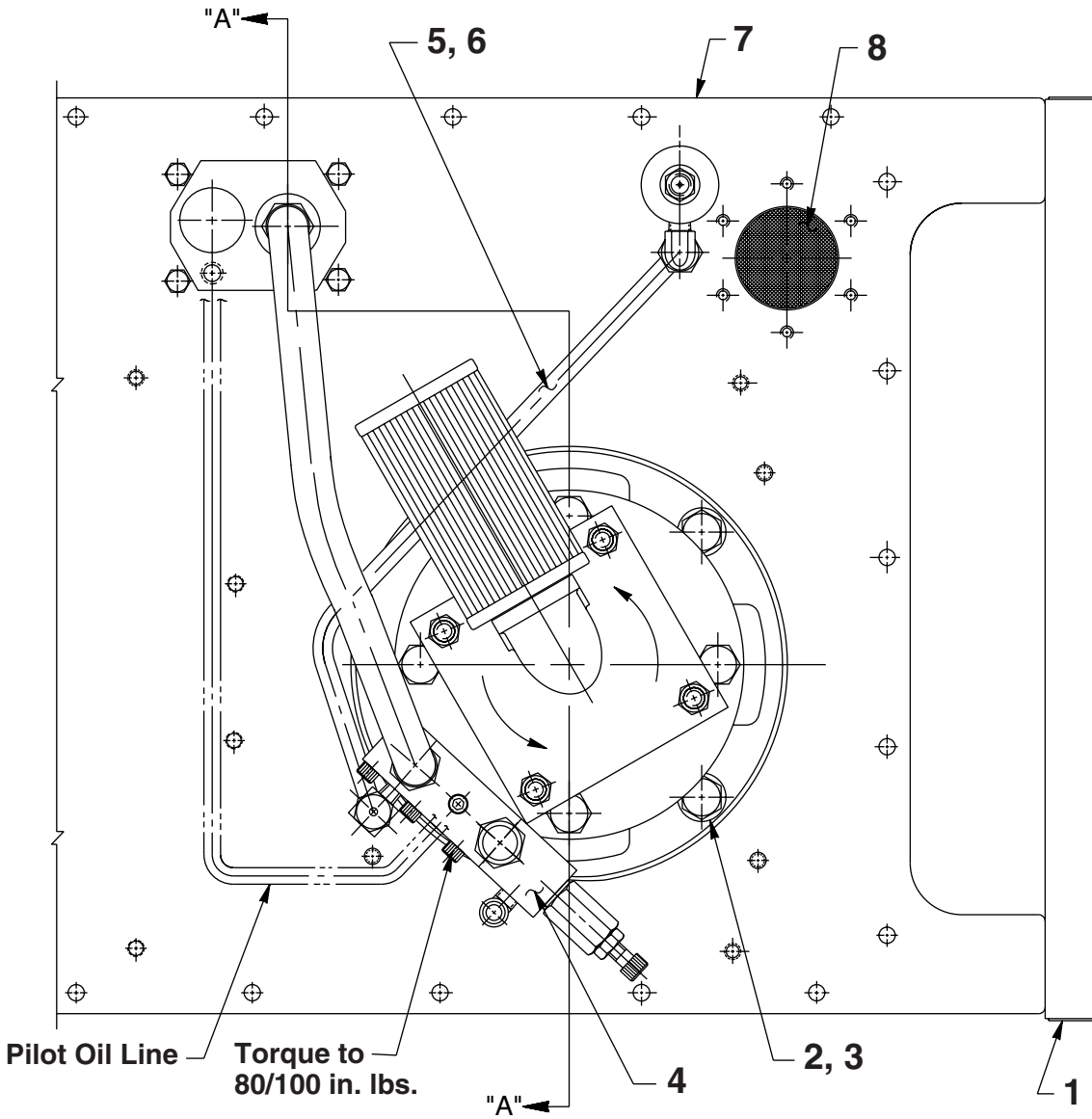

Item No.	Part No.	No. Req'd	Description
1	12126	4	Square Insert
2	11623	4	Hex. Hd. Cap Screw (1/2-13 x 1-1/4 Lg.)
3	10249	4	Spring Lockwasher (1/2)
4	42795	1	Unloading Valve Assembly (See back sheet 4 of 9)
5	43647	1	Oil Line (Pressure Regulator; See sheet 4 of 9; Note: Not part of PG4004-HONDA & PG4004-BAR)
6	12696	1	Straight Connector
7	51098WH2	1	Cover Plate Weldment
8	13167	1	Filter/Breather Assembly

PARTS INCLUDED BUT NOT SHOWN

10432	1	Snap Plug (For PG4004-HONDA & PG4004-BAR)
10427	1	Plug Fitting (1/8 NPTF; For PG4004-HONDA & PG4004-BAR)

PRESSURE REGULATOR ASSEMBLY

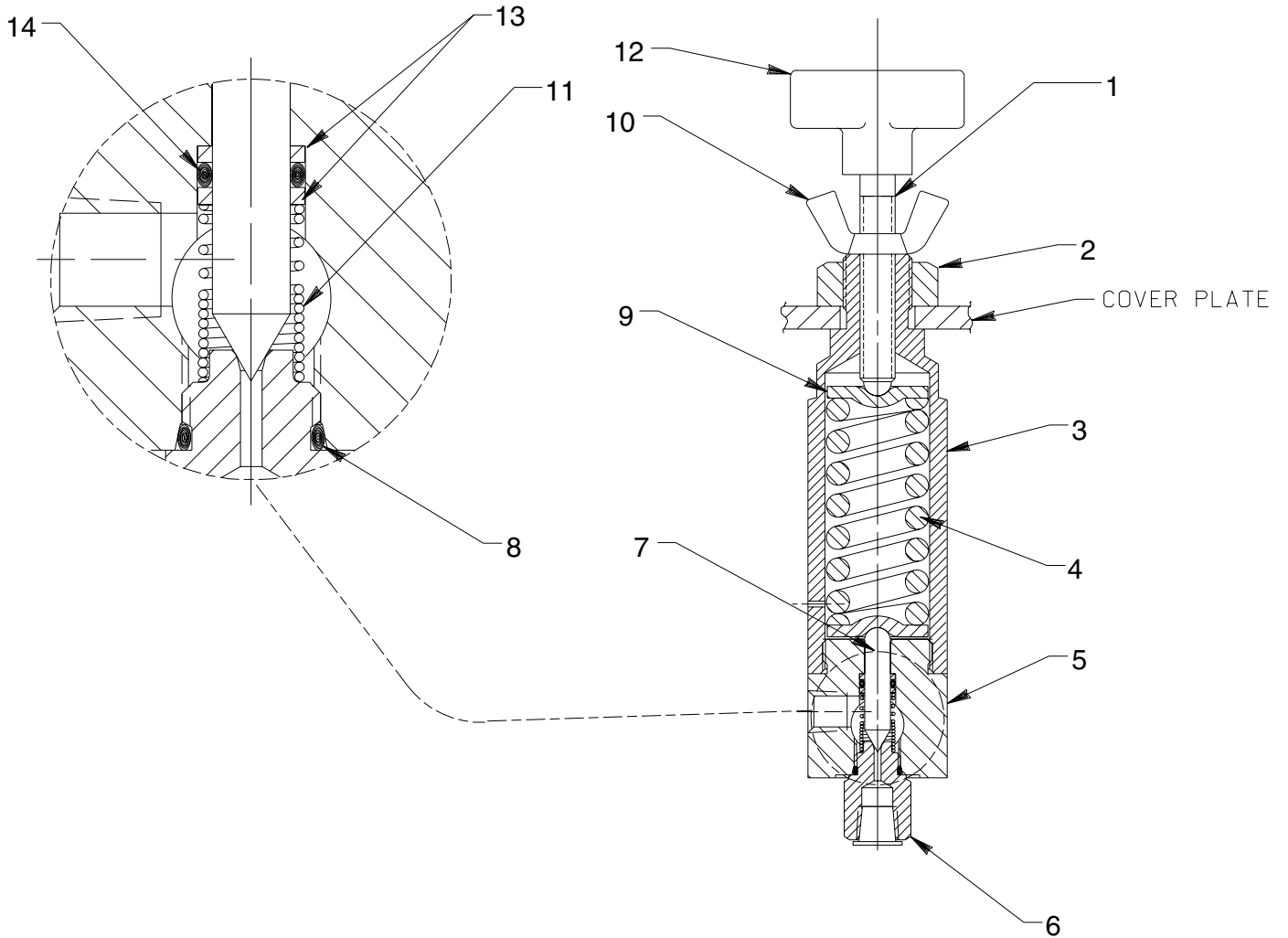

Item No.	Part No.	No. Req'd	Description
1	215721	1	Stem (NOTE: Assemble to Tee Knob [Item #12] with Loctite No. 242 or equivalent.)
2	10396	1	Jam Nut (3/4-16)
3	309077	1	Spring Housing
4	215429	1	Compression Spring (1.100 O.D. x 2-1/2 Lg.)
5	47648	1	Regulator Body
6	309078	1	Seat Fitting
7	309079	1	Poppet
8	13755	1	O-ring (9/16 x 13/32 x 5/64)
9	215428	2	Spring Retainer (Grease pocket before assembling. [Both sides])
10	215683	1	Wing Nut
11	215431	1	Compression Spring (NOTE: Assemble closed coils of spring form towards seat fitting [Item #6].)
12	215693	1	Tee Knob
13	215430	2	Backup Washer (3/8 x 9/32 x 3/64)
14	10266	1	O-ring (3/8 x 1/4 x 1/16)

PARTS INCLUDED BUT NOT SHOWN

11127	2	Plug (3/8 NPTF Male)
10427	1	Plug (1/8 NPTF Male Hex)
10475	1	90° Tube Elbow
14463	1	Pipe Nipple (5-1/2 Lg.)

Sheet No. 4 of 9

Rev. 2 Date: 20 Oct. 2000

UNLOADING VALVE ASSEMBLY

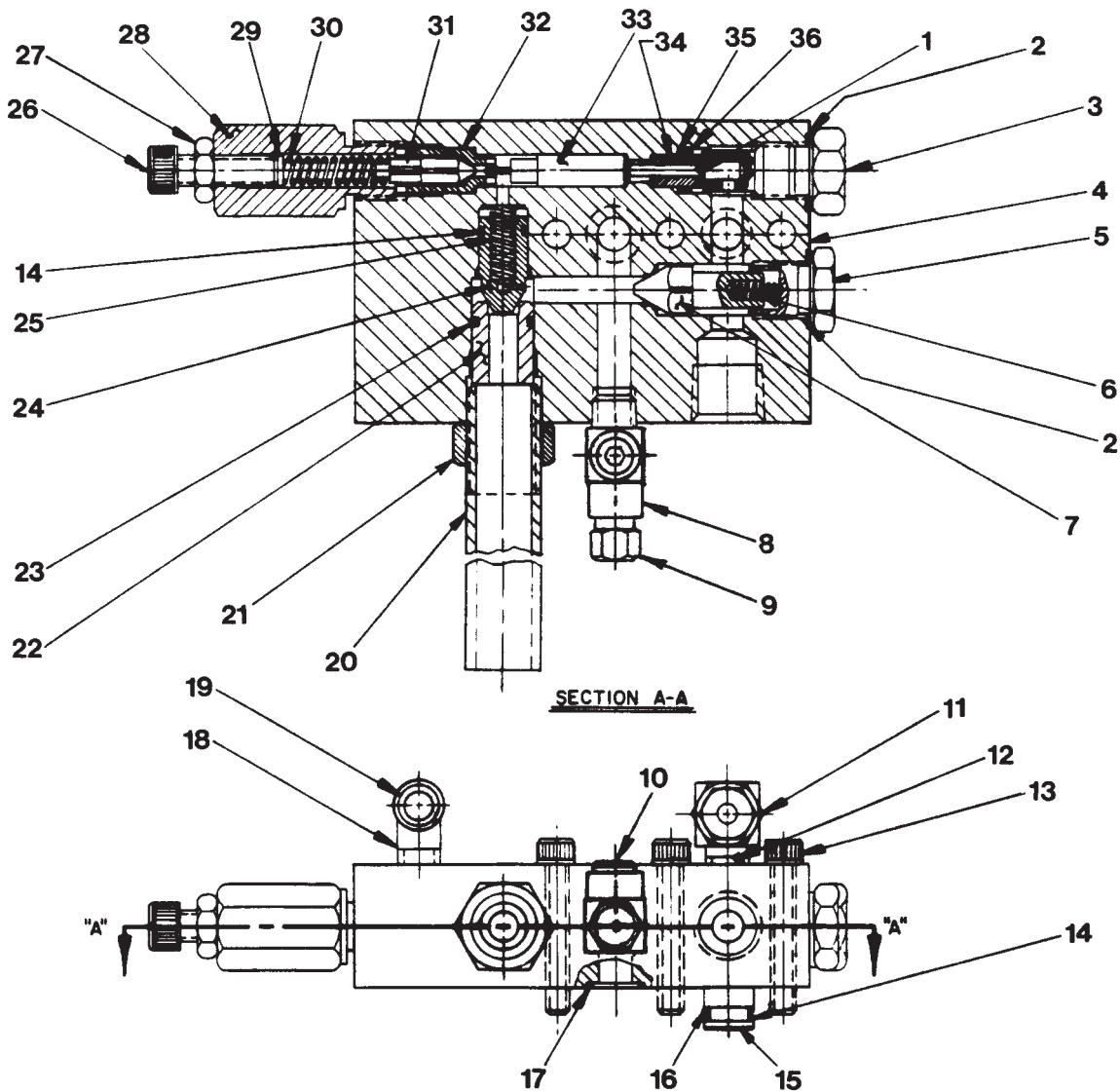

Item No.	Part No.	No. Req'd	Description
1	12149	1	Dowel Pin (1/8 dia. x 3/4 Lg.)
2	10261	2	Copper Washer (19/32 x 3/4 x 1/32)
3	37430	1	Adapter (Torque to 35/40 ft. lbs.)
4	60414	1	Valve Body
5	205394	1	Valve Plug (Torque to 35/40 ft. lbs.)
6	15141	1	Compression Spring (.180 O.D. x 5/8 Lg.)
7	205393	1	Poppet (Seat at assembly)
8	18969	1	Tee Fitting
9	306957	1	Air Bleed Valve
10	10427	1	Pipe Plug (1/8 NPTF)
11	21278	1	Relief Valve Assembly (Set at 10,100/10,700 PSI)
12	24702	1	Tee
13	10022	3	Soc. Hd. Cap Screw (1/4-20 x 1-1/2 Lg.)
14	10268	3	O-ring (1/2 x 3/8 x 1/16)
15	21094	1	Bushing
16	11863	2	Teflon Backup Washer
17	12098	1	O-ring (9/16 x 7/16 x 1/16)
18	13229	1	90° Elbow

Item No.	Part No.	No. Req'd	Description
19	14463	1	Drain Tube
20	203620	1	Drain Tube
21	10396	1	Jam Nut (3/4-16)
22	203621	1	Bushing
23	10301	1	O-ring (5/8 x 1/2 x 1/16)
24	37423	1	Poppet (Seat at assembly)
25	11221	1	Compression Spring (.240 O.D. x 1" Lg.)
26	11013	1	Soc. Hd. Cap Screw (5/16-18 x 1" Lg.)
27	10385	1	Jam Nut (5/16-18)
28	36545	1	Fitting (Torque to 25/30 ft. lbs.)
29	16528	1	Spacer
30	17413	1	Compression Spring
31	203541	1	Poppet (Seat at assembly)
32	37427	1	Guide
33	203540	1	Plunger Assembly
34	17414	1	Bushing (1/16 x 1/8 x 1/2 Lg.)
35	15085	1	Teflon Backup Washer (7/16 x 5/16 x 1/16)
36	10267	1	O-ring (7/16 x 5/16 x 1/16)

FRAME & RESERVOIR ASSEMBLY SIDE VIEW

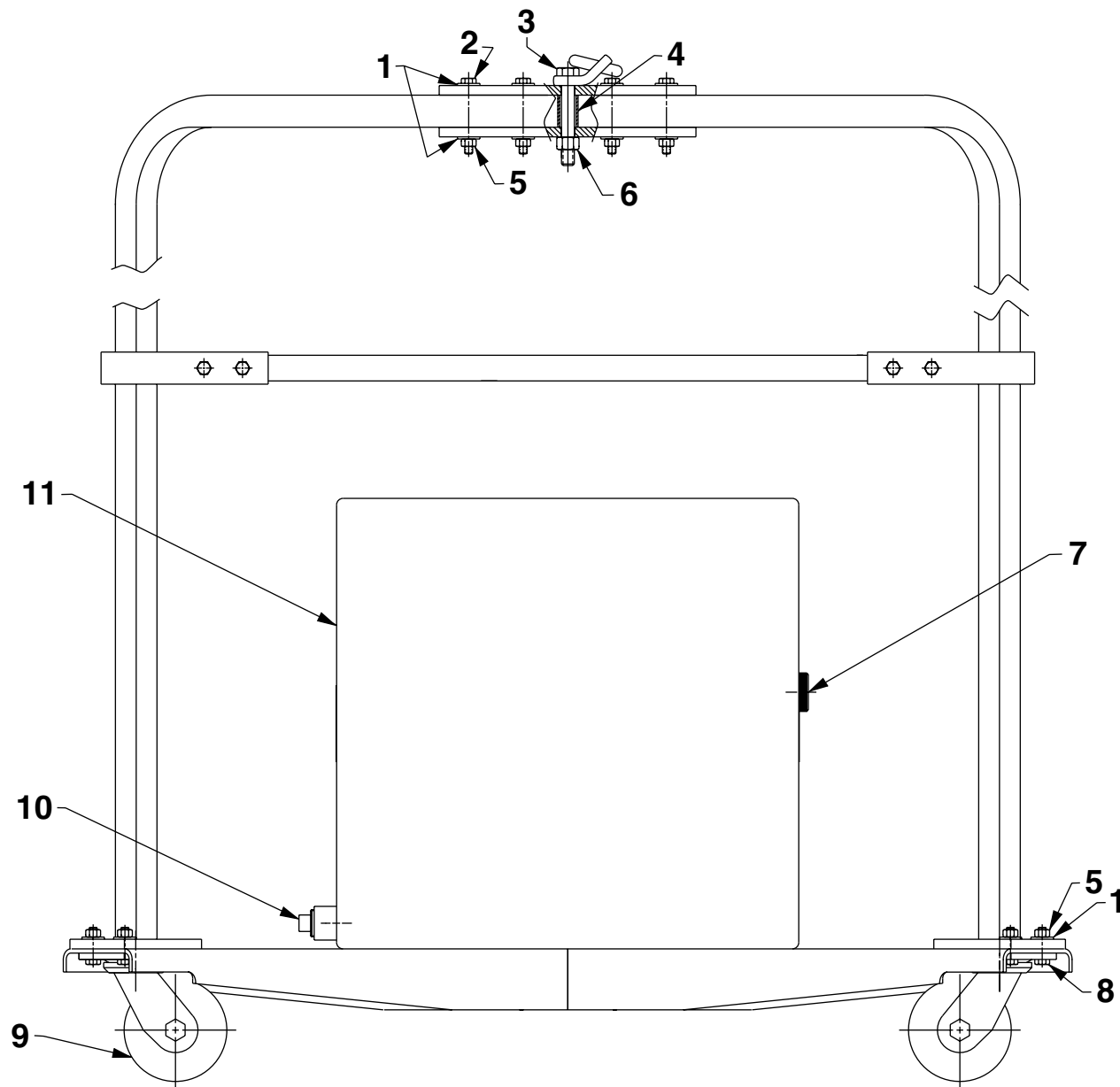

Item No.	Part No.	No. Req'd	Description
1	10230	32	Washer, Wrought (.89 x .38)
2	10041	8	Screw, HH Cap (5/16-18 x 2-3/4)
3	18213	1	Screw, HH Cap (1/2-13 x 3-1/2)
4	208111	1	Spacer (.797 x .647)
5	13116	24	Nut, Hex Lock (5/16-18)
6	15013	1	Nut, Hex Lock (1/2-13)
7	17586	1	Gauge, Sight (1-1/2")
8	10559	16	Screw, HH Cap (5/16-18 x 1-1/4)
9	214486	4	Caster, Swivel (4")
10	11049	1	Fitting, Plug (3/4 NPTF)
11	61553OR9	1	Reservoir

FRAME & RESERVOIR ASSEMBLY TOP VIEW

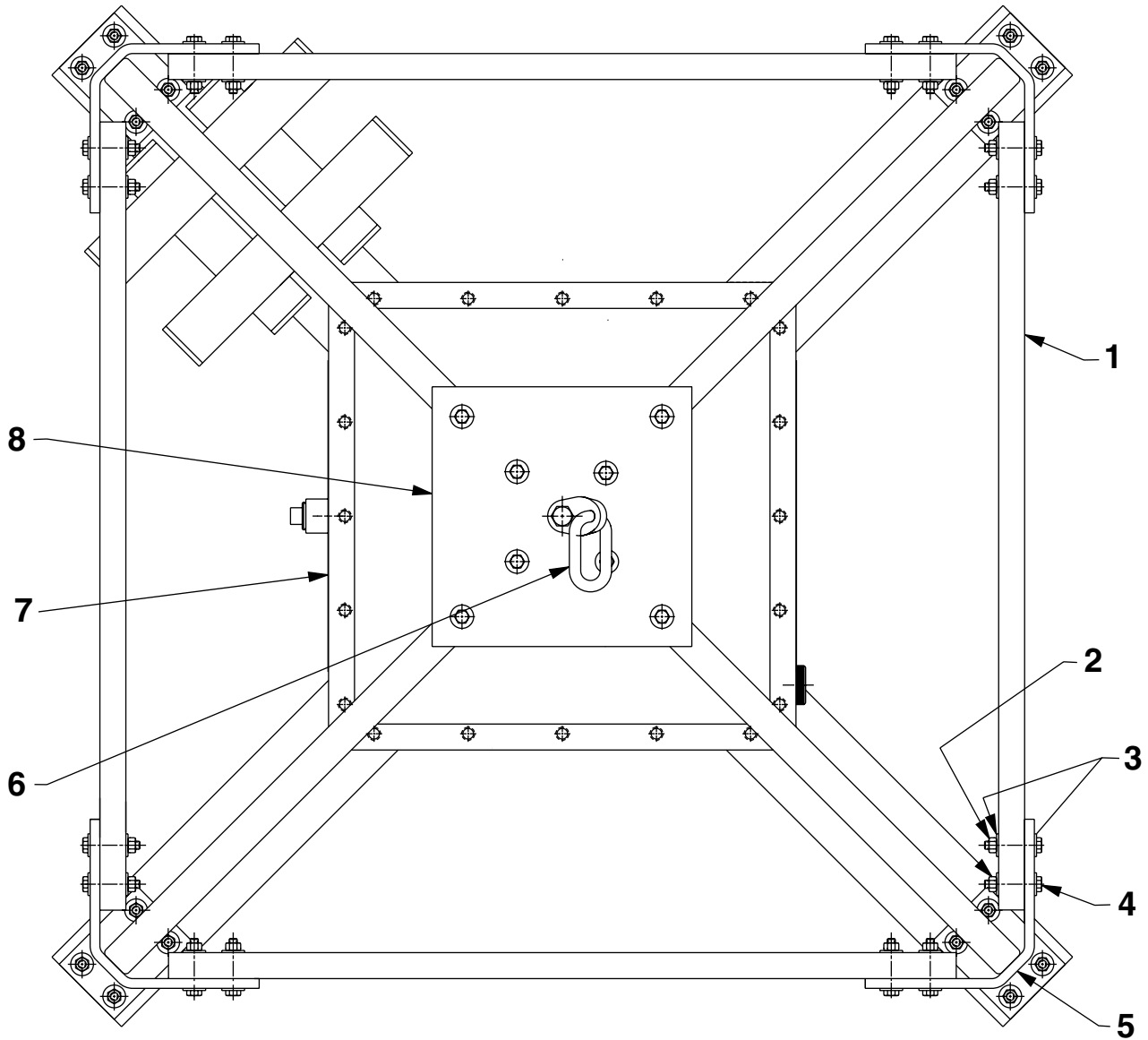

Item No.	Part No.	No. Req'd	Description
1	214204BK2	4	Arm, Support
2	13116	16	Nut, Hex Lock (5/16-18)
3	10230	32	Washer, Wrought (.89 x .38)
4	10036	16	Screw, Hex Hd Cap (5/16-18 x 2)
5	53039BK2	4	Leg, Roll Cage
6	24247	1	Bracket, Link
7	309221	2	Decal, Trade Name Power Team
8	46989BK2	2	Plate, Top

MOTOR CONTROL ASSEMBLY SIDE VIEW

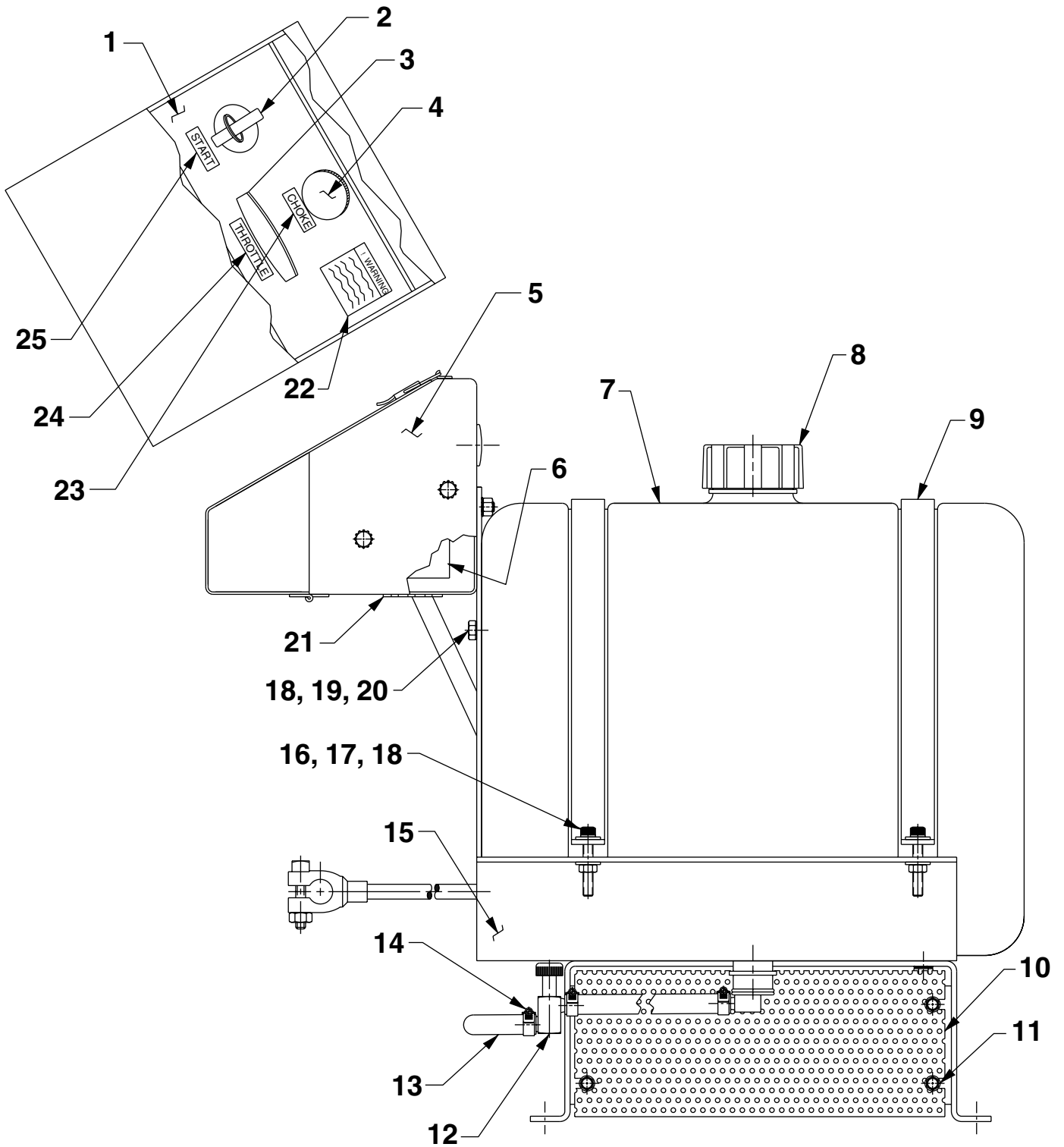

Parts List, Form No. 108063, Back sheet 6 of 9

Item No.	Part No.	No. Req'd	Description
1	421877BK2	1	Bracket, Switch
2	253589	1	Switch, Key Starter
3	253588	1	Throttle
4	251917	1	Control, Choke
5	53041BK2	1	Box, Electrical Control
6	352084	1	Relay, Time Delay
7	66128	1	Tank, Gas
8	253521	1	Cap, Filler Breather
9	421891	2	Support, Fuel Tank
10	37616WH2	2	Guard, Screen
11	14456	8	Screw, Hex Wshr Hd (10-24 x 1/2)
12	253590	1	Valve, Fuel Line
13	212801	3'	Hose, Rubber
14	210331	4	Clamp, Hose
15	66199BK2	1	Bracket, Mounting
16	10022	2	Screw, Soc Hd (1/4-20 x 1-1/2)
17	12719	4	Washer, Plain (.63 x .29)
18	12809	3	Nut, Hex Lock (1/4-20)
19	11351	1	Washer, Tooth Ext (.50 x .26)
20	10005	1	Screw, Hex Hd Cap (1/4-20 x 1/2)
21	213390	.25'	Channel, Rubber
22	203756	1	Decal, Caution
23	251920	1	Decal, Label Choke
24	251919	1	Decal, Label Throttle
25	203808	1	Decal, Label Start

MOTOR CONTROL ASSEMBLY SIDE VIEW

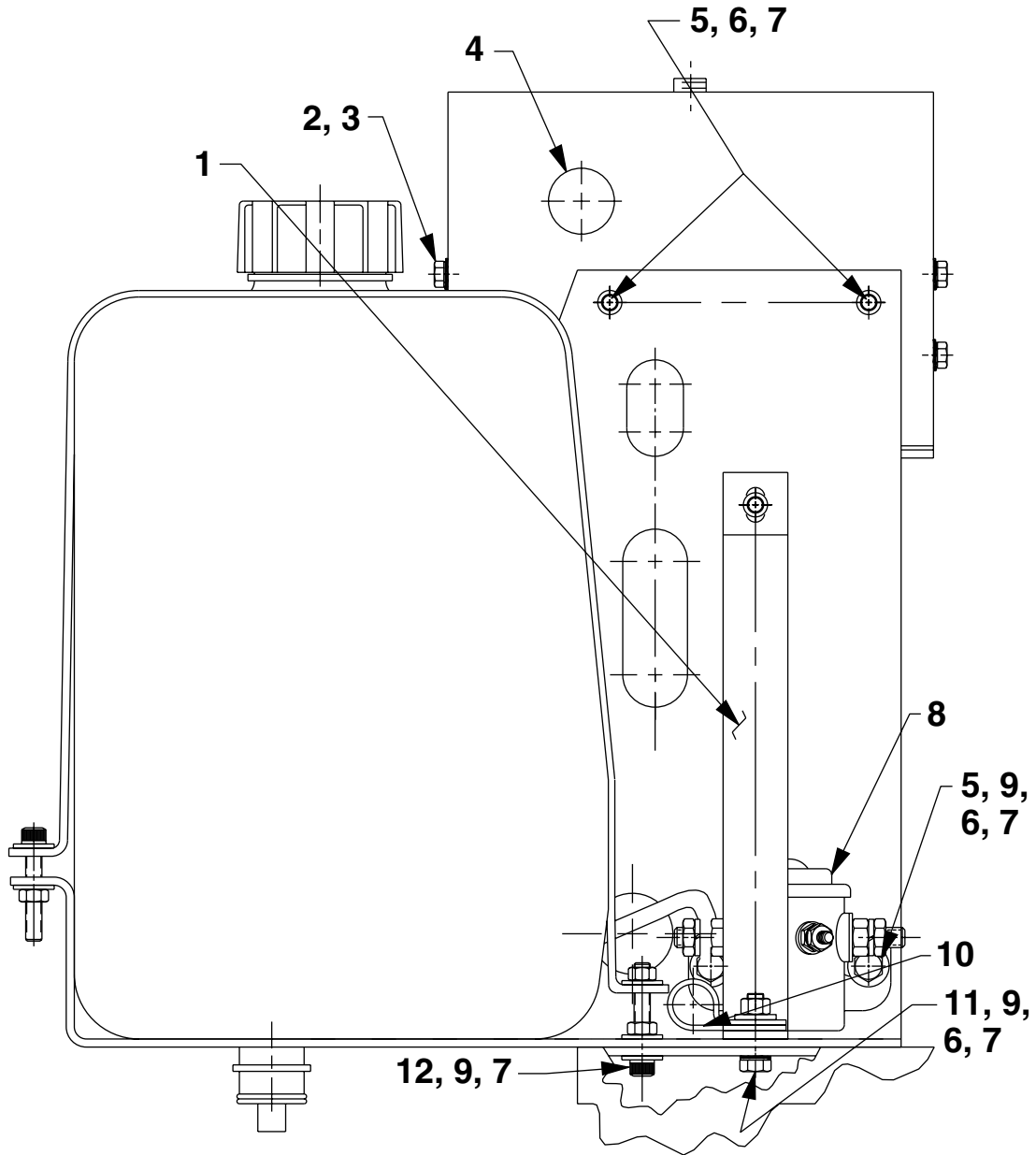

Item No.	Part No.	No. Req'd	Description
1	421874BK2	1	Bracket, Support
2	14456	4	Screw, Hex Wshr Hd (10-24 x 1/2)
3	11108	8	Washer, Tooth Ext (.40 x .20)
4	15327	1	Button, Snap
5	10009	4	Screw, Hex Hd Cap (1/4-20 x 3/4)
6	11351	6	Washer, Tooth Ext (.50 x .26)

Item No.	Part No.	No. Req'd	Description
7	12809	11	Nut, Hex Lock (1/4-20)
8	14912	1	Solenoid (12 VDC)
9	12719	10	Washer, Plain (.63 x .29)
10	207984	1	Clamp, Conduit
11	10017	2	Screw, Hex Hd Cap (1/4-20 x 1)
12	10022	2	Screw, Soc Hd (1/4-20 x 1-1/2)

WIRING DIAGRAM FOR PG4004

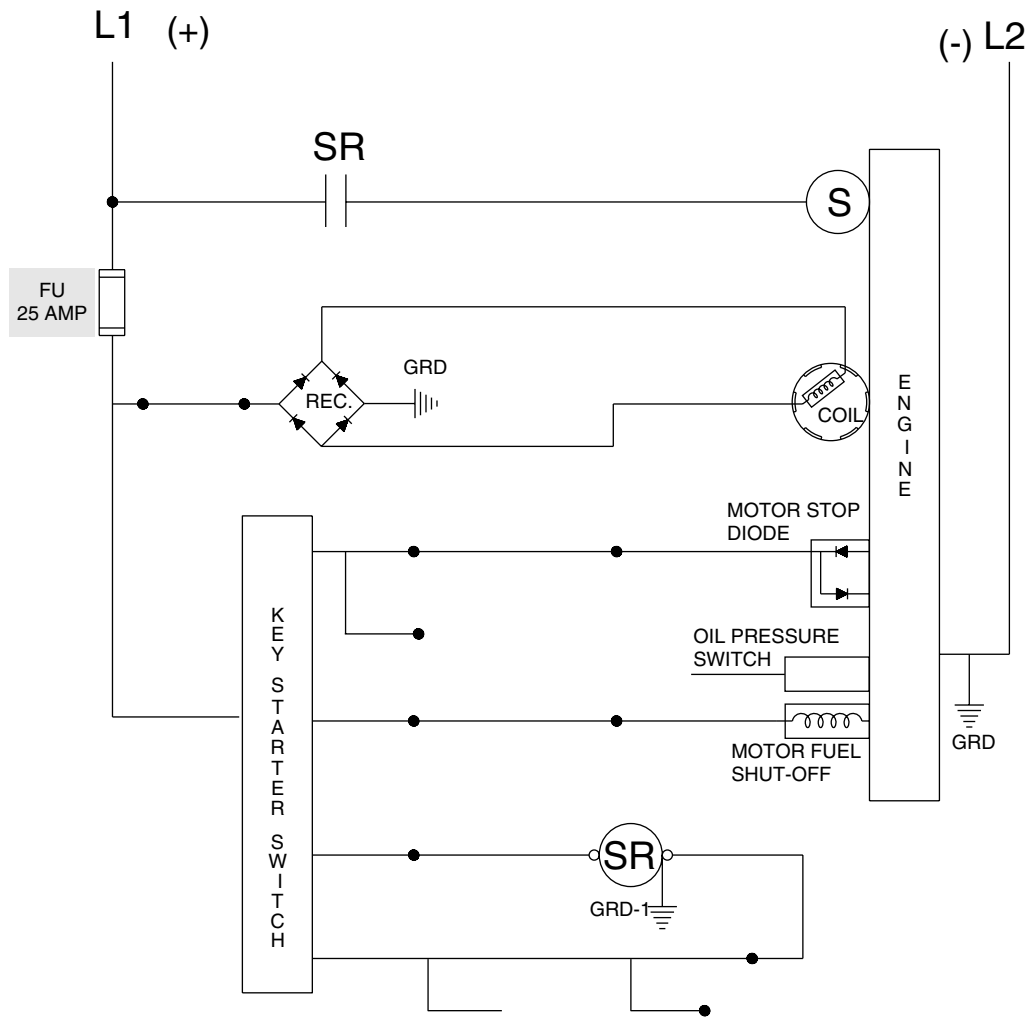

Note: Shaded areas reflect last revision(s) made to this form.

WIRING DIAGRAM FOR PG4004S

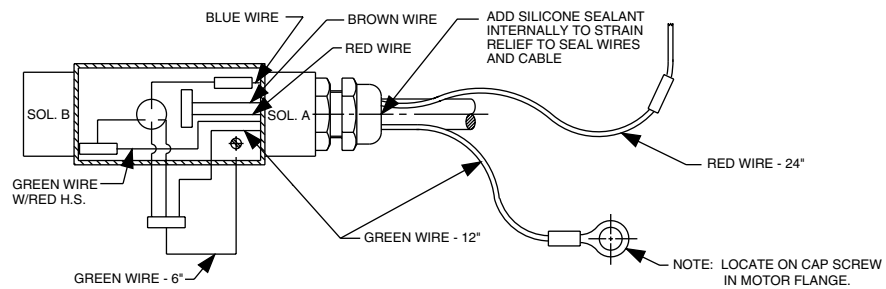
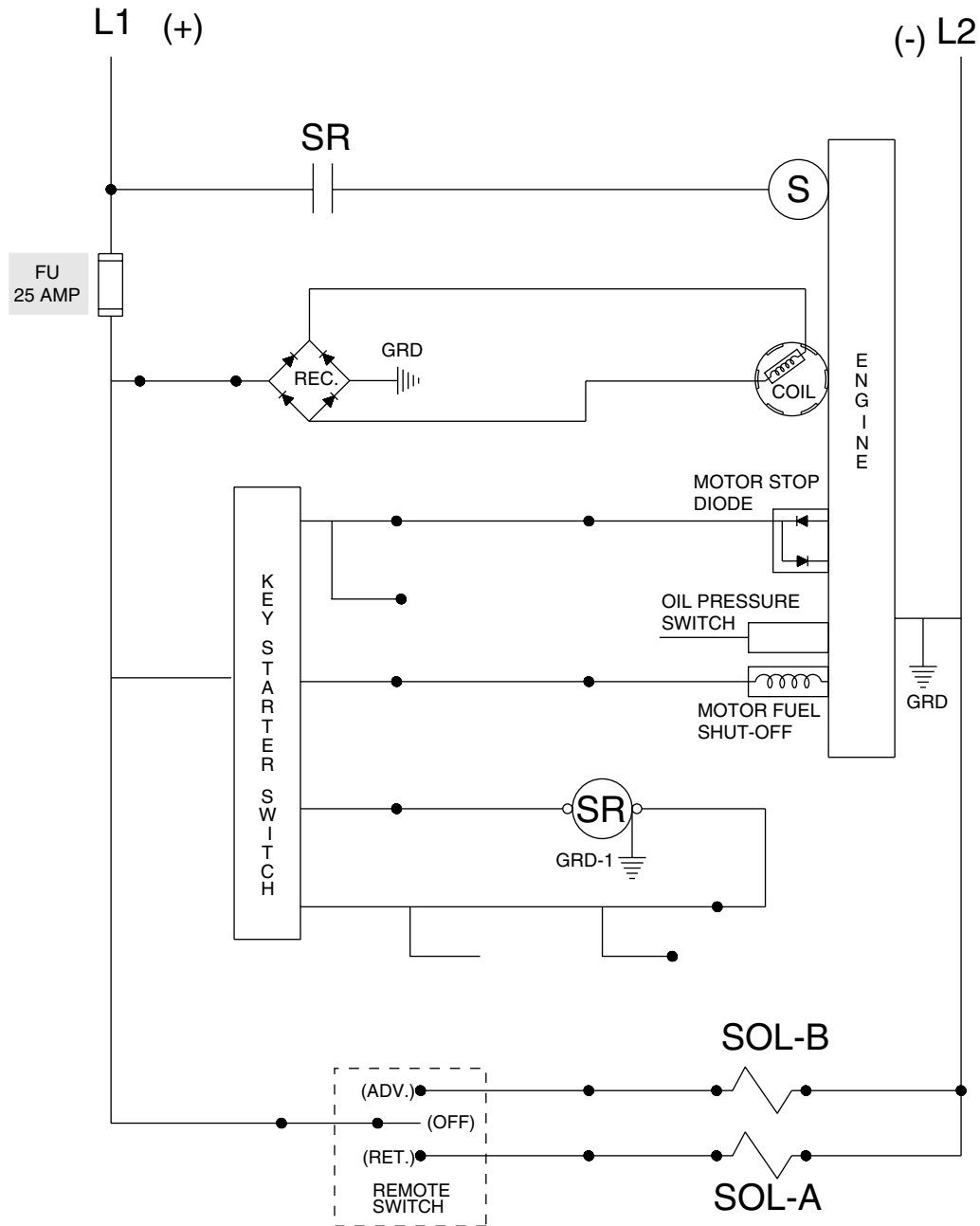

Note: Shaded areas reflect last revision(s) made to this form.

WIRING DIAGRAM FOR PG4004-HONDA & PG4004-BAR

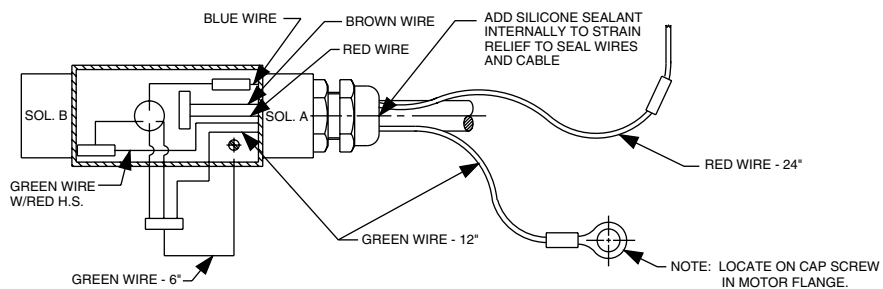
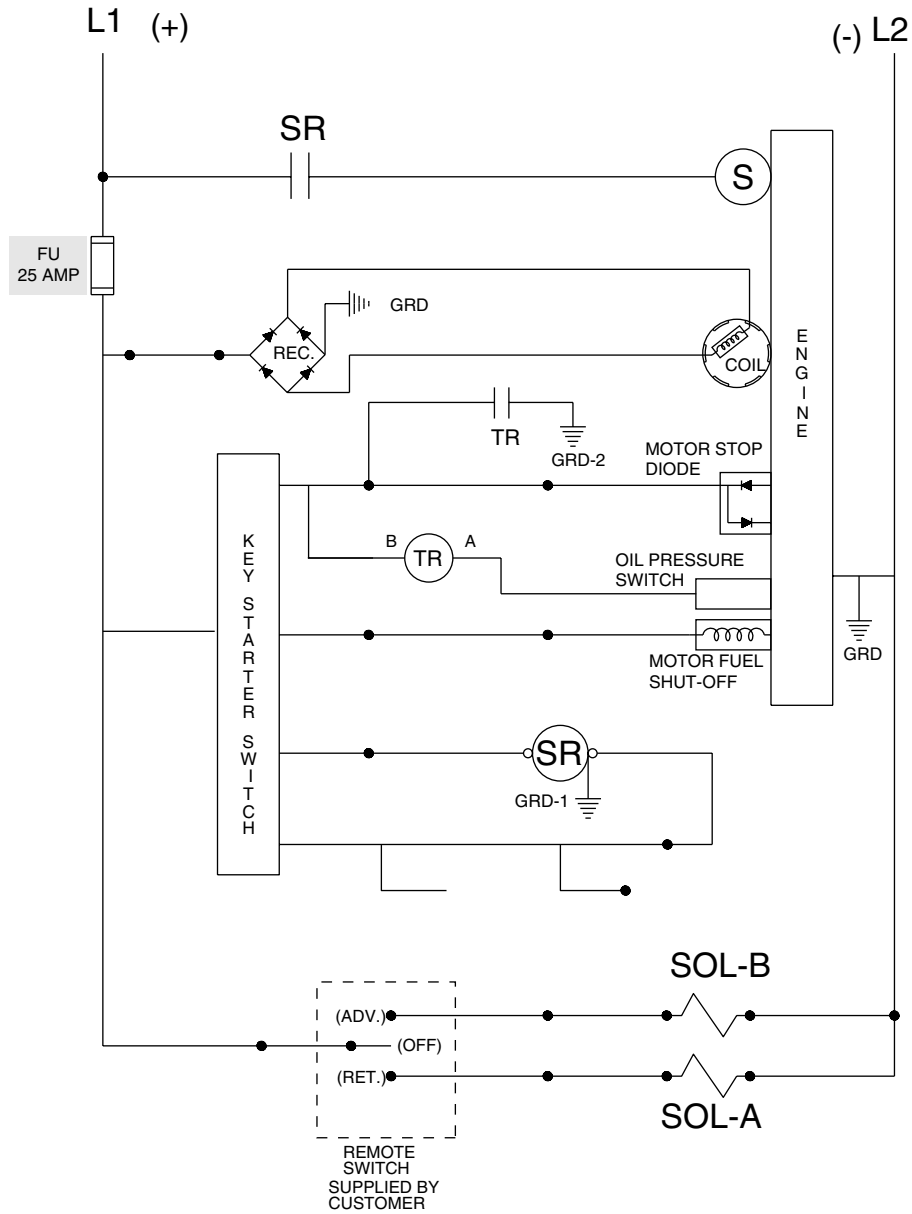

Note: Shaded areas reflect last revision(s) made to this form.

REMOTE CONTROL HAND SWITCH ASSEMBLY

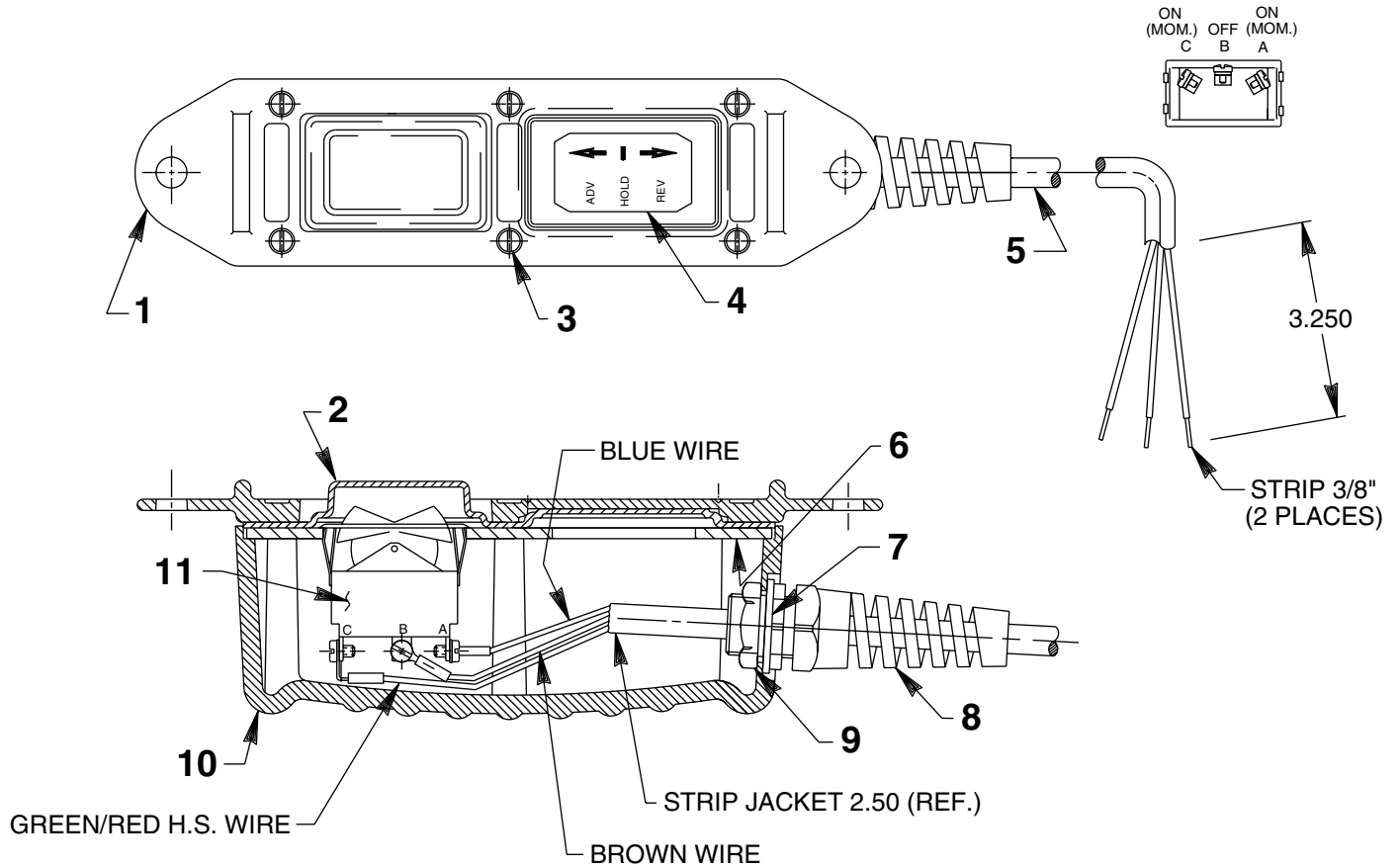

Item No.	Part No.	No. Req'd	Description
1	420050-1	1	Cover, Plastic
2	420050-2	1	Gasket, Remote Hand Switch
3	250248	6	Screw, Pan Head (4-24 x 3/4)
4	202776	1	Decal, Label Controls
5	251879	25'	Cable (1.5MM/3 HAR)
6	420050-3	1	Plate, Switch Mounting
7	253607	1	Gasket, Rubber
8	251818	1	Bushing, Strain Relief
9	251802	1	Nut, Hex Lock (Torque to 30 in. lbs.)
10	420050-4	1	Housing, Switch
11	16773	1	Switch, Rocker