

## MODEL B GAS HYDRAULIC PUMP Max. Capacity: 10,000 PSI

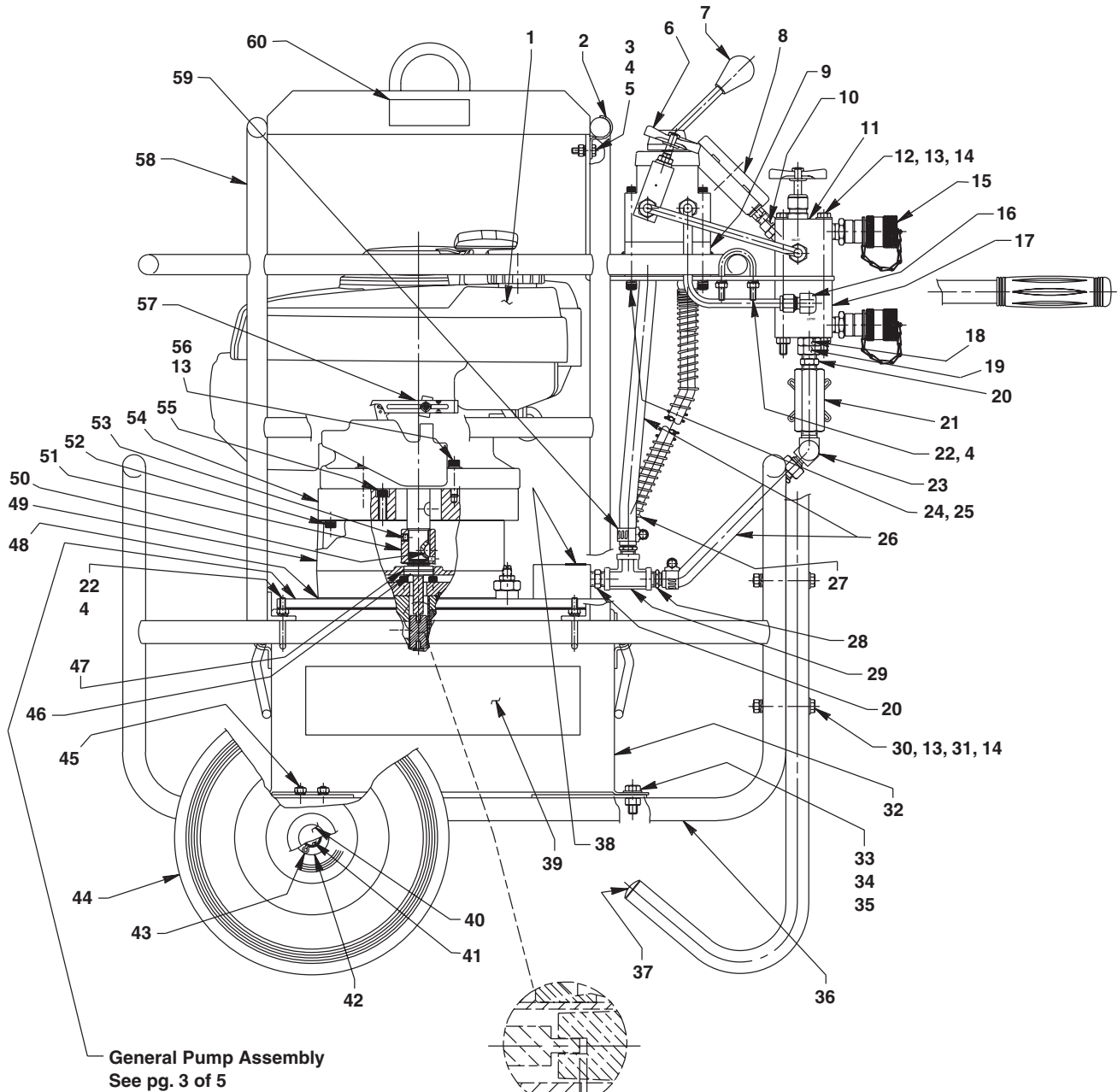

General Pump Assembly  
See pg. 3 of 5

.010  
.040

(Distance between bottom of shaft adapter [Item #51] and bottom of slot in nylon coupler [Item #19 on sheet 4 of 5])

# Parts List, Form No. 108090, Back sheet 1 of 5

Item No.	Part No.	No. Req'd	Description	Item No.	Part No.	No. Req'd	Description
1	420202	1	Gasoline Engine (Honda 5.5 H.P.)	27	307968	1	Hydraulic Hose (1/4 I.D. x 2 ft. lg.)
2	250369	2	Conduit Clamp (3/4)	28	250370	2	Barbed Hose Fitting (3/8 NPTF; for PG1200M-4)
3	10009	2	Hex Cap Screw (1/4-20 UNC x 3/4 Lg.)		250370	4	Barbed Hose Fitting (3/8 NPTF; for PG1200M-4D)
4	10245	18	Lockwasher (1/4 I.D.)	29	214488	1	Tee Fitting (for PG1200M-4D)
5	10199	2	Hex Nut (1/4-20 UNC)	30	10039	4	Hex Hd. Cap Screw (5/16-18 UNC x 2-1/2 Lg.)
6	46647	1	Restrictor Valve (See form #100666)	31	10246	4	Lockwasher (5/16 I.D.)
7	9520	1	Valve Assembly (3 position/3-way; for PG1200M-4; see forms #101377 & #102527)	32	401370R9	1	Reservoir (5 gal.)
	9506	1	Valve Assembly (3 position/4-way; for PG1200M-4D; see forms #100628 & 102527)	33	10049	4	Hex Hd. Cap Screw (3/8-16 UNC x 1" Lg.)
8	9052	1	Pressure Gauge (Liquid filled - 10,000 PSI)	34	10258	4	Washer
9	46244	1	Subplate (See form #102529)	35	10204	4	Hex Nut (3/8-16 UNC)
10	12740	1	Straight Fitting	36	60855BK2	1	Frame
11	420076	1	Remote Metering Valve (See form #101206)	37	10432	6	Snap Plug
12	10041	4	Hex Hd. Cap Screw (5/16-18 UNC x 2-3/4 Lg.; for PG1200M-4)	38	211167	1	Decal (For manifold)
	250382	4	Hex Hd. Cap Screw (5/16-18 UNC x 6" Lg.; for PG1200M-4D)	39	309221	2	Trade Name Decal
13	10257	10	Flat Washer (5/16 I.D.)	40	206737	2	Hub Cap
14	10201	8	Hex Nut (5/16-18 UNC)	41	307004	1	Axle (3/4" dia.)
15	9796	4	Quick Disconnect Coupler (for PG1200M-4)	42	12330	6	Plain Washer (3/4 I.D.; NOTE: Use one washer on each side of wheel (both sides) & use remaining two washers to take up any excessive movement of wheels.)
	9796	8	Quick Disconnect Coupler (for PG1200M-4D)	43	10573	2	Cotter Pin (1/8 x 1-1/4 Lg.)
16	10666	1	90° Elbow Fitting (for PG1200M-4D)	44	212876	2	Wheel (12" dia.)
17	58055	1	Metering Valve Body (for PG1200M-4D)	45	206270	2	U-bolt with Nut (1/4)
18	11946	3	O-ring Boss Plug (3/4-16 UNF; for PG1200M-4D)	46	10439	1	Radial Ball Bearing
19	205956	1	Straight Fitting (for PG1200M-4D)	47	15124	1	O-ring (1-3/8 x 1-1/4 x 1/16)
20	10673	2	Straight Hex Nipple Fitting (for PG1200M-4D)	48	40987	1	Gasket
21	9575	1	Manual Directional Control Valve (for PG1200M-4D)	49	*50384WH2	1	Motor Base
22	209355	6	U-bolt with Nut	50	10945	1	Woodruff Key (No. 6)
23	10648	1	45° Swivel Elbow Fitting (for PG1200M-4)	51	420052	1	Shaft Extension
	10648	2	45° Swivel Elbow Fitting (for PG1200M-4D)	52	*251566	1	Cap Screw (5/16-24 UNF x 2" Lg.)
24	10008	4	Soc. Hd. Cap Screw (1/4-20 UNC x 3/4 Lg.)	53	10556	1	Hex Soc. Hd. Set Screw (1/4-20 UNC x 1/4 Lg.)
25	12719	4	Plain Washer (1/4 I.D.)	54	*420200	1	Gas Engine Mounting Plate
26	250380	1	Hydraulic Hose (1/2 I.D. x 1-1/2 ft. lg.; for PG1200M-4)	55	250427	4	Soc. Hd. Cap Screw (5/16-18 UNC x 1/2 Lg.)
	250380	2	Hydraulic Hose (1/2 I.D. x 1-1/2 ft. lg.; for PG1200M-4D)	56	10948	2	Soc. Hd. Cap Screw (5/16-18 UNC x 1-1/2 Lg.)
				57	17596	1	Slide Control
				58	46456BK2	1	Roll Cage Frame
				60	202173	2	Decal
				59	12367	2	Hose Clamp
							<b>PARTS INCLUDED BUT NOT SHOWN</b>
					10474	1	90° Elbow Fitting (for PG1200M-4)

**\*Note: If replacing any of these parts on a pump manufactured before 7-1-94, order motor base replacement kit no. 251571.**

TOP VIEW

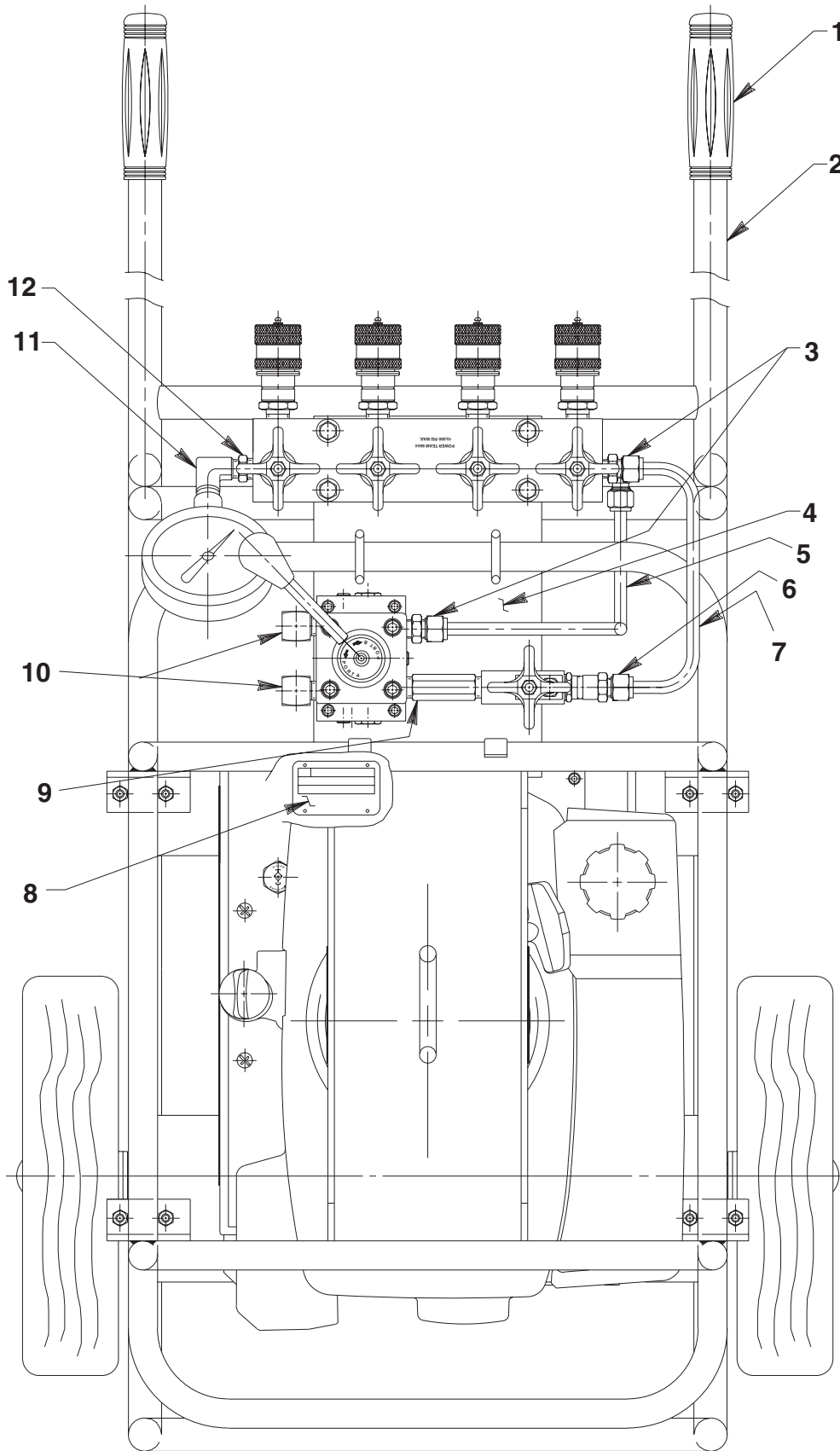

Item No.	Part No.	No. Req'd	Description
1	206731	2	Rubber Grip
2	46455BK2	1	Handle
3	10662	1	Straight Fitting (For PG1200M-4)
	10662	2	Straight Fitting (For PG1200M-4D)
4	58122BK2	1	Mounting Bracket
5	350234	1	Oil Line Tube (For PG1200M-4D)
6	10660	1	Straight Fitting
7	350233	1	Oil Line Tube
8	202120CE	1	Name Plate
9	9683	1	Straight Hex Nipple Fitting
10	10474	2	90° Elbow Fitting
11	250381	1	90° Elbow Fitting
12	10676	1	Straight Fitting

### HYDRAULIC SCHEMATIC

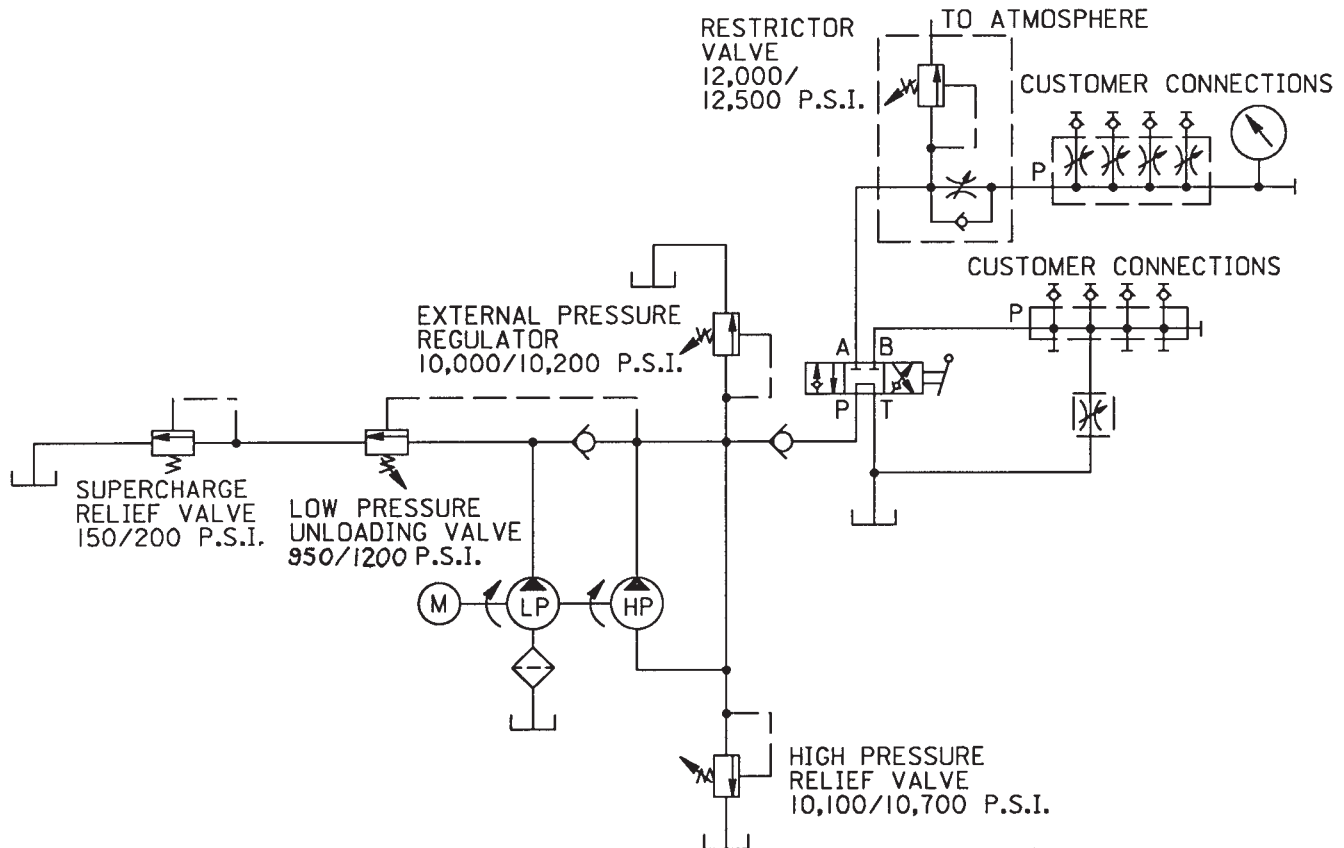

### GENERAL PUMP ASSEMBLY

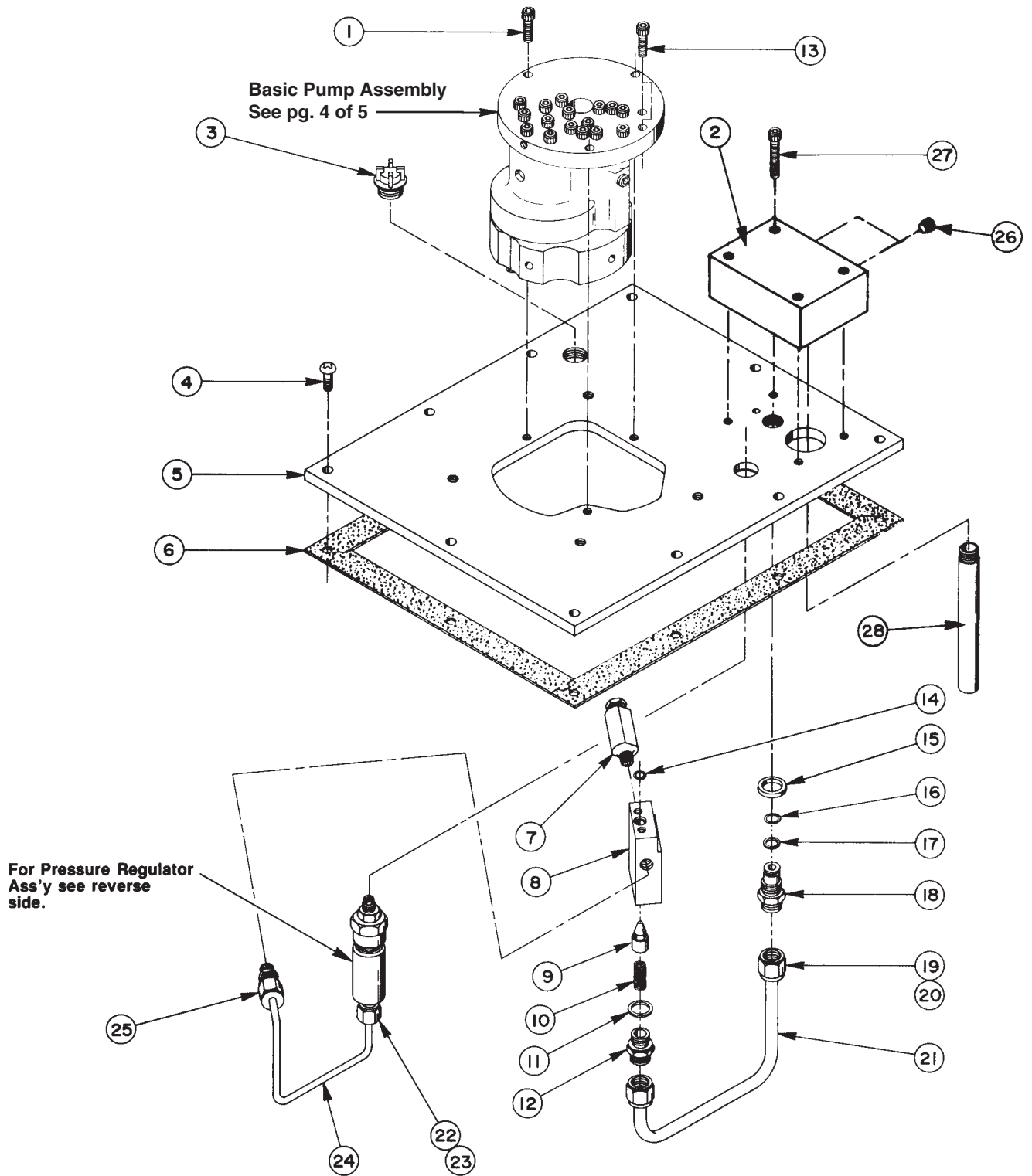

Item No.	Part No.	No. Req'd	Description	Item No.	Part No.	No. Req'd	Description
1	10016	3	Soc. Hd. Cap Screw (1/4-20 UNC x 1" Lg.)	16	10268	1	O-ring
2	45911	1	Manifold Body	17	11863	1	Teflon Backup Washer
3	20937	1	Filler Plug	18	20787	1	Valve Connector
4	10177	10	Machine Screw (1/4-20 UNC x 3/4 Lg.)	19	10430	2	Tube Sleeve
5	50058WH2	1	Cover	20	10431	2	Tube Nut
6	58506	1	Gasket	21	21495	1	Oil Line Tube
7	21278	1	Relief Valve Assembly (Set at 10,100/10,700 PSI)	22	11342	1	Tube Nut
8	20776	1	Valve Body	23	11174	1	Tube Sleeve
9	20771	1	Poppet	24	22399	1	External Pressure Regulator Tube
10	10425	1	Compression Spring (3/8 O.D. x 3/4 Lg.)	25	11173	1	Straight Fitting
11	10261	1	Copper Washer	26	10479	2	Pipe Plug
12	20770	1	Connector (Torque to 40/45 in. lbs.)	27	10022	4	Soc. Hd. Cap Screw (1/4-20 UNC x 1-1/2 Lg.)
13	10015	2	Soc. Hd. Cap Screw (1/4-28 UNF x 1" Lg.; Torque to 180 in. lbs.)	28	200609	1	Drain Tube
14	10266	1	O-ring (1/4 x 3/8 x 1/16)				
15	21484	1	Spacer				

### PRESSURE REGULATOR ASSEMBLY

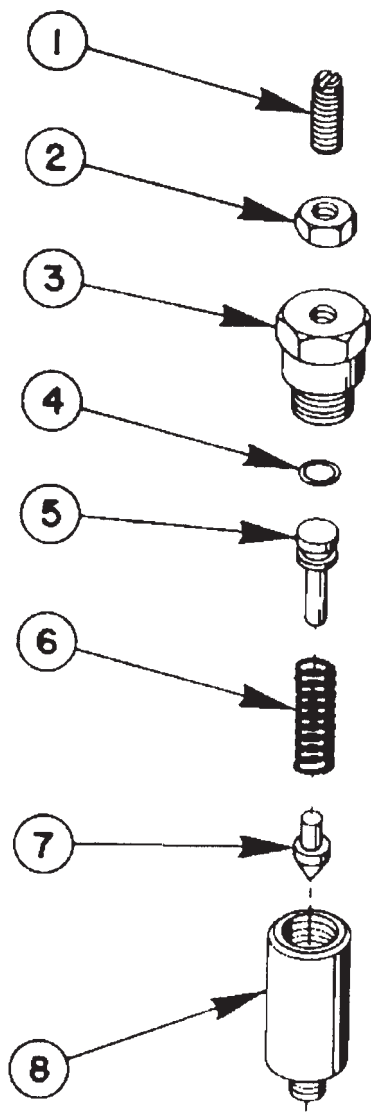

Item No.	Part No.	No. Req'd	Description
1	22362	1	Adjusting Screw (Set at 10,000/10,200 PSI)
2	10386	1	Hex Nut (3/8-24 UNF)
3	21305	1	Valve Cap
4	10268	1	O-ring
5	21306	1	Spring Guide
6	10495	1	Compression Spring (.45 x 1-5/8 Lg.)
7	21046	1	Valve Stem
8	22361	1	Body



Item No.	Part No.	No. Req'd	Description
1	10020	9	Soc. Hd. Cap Screw (1/4-20 UNC x 1-1/4 Lg.; Torque to 170/180 in. lbs.)
2	33114	1	High Pressure Pump Assembly (See pg. 5 of 5)
3	10361	1	Compression Spring (1/4 O.D. x 1" Lg.)
4	10375	1	Steel Ball (1/4 dia.)
5	23547	1	Bearing Top Plate
6	23548	1	Top Plate
7	11228	2	Thrust Needle Bearing
8	11813	3	Needle Thrust Race Bearing
9	11814	1	Ball Bearing
10	23549	1	Angle Plate
11	11955	1	Roll Pin (1/4 dia. x 3/4 Lg.)
12	11064	2	Needle Bearing
13	11261	2	Retaining Ring
14	23556	1	Shaft
15	11821	1	Woodruff Key (No. 3)
16	23557	1	Gear
17	30533	1	Pump End Plate
18	10001	12	Soc. Hd. Cap Screw (#10-32 UNF x 1-3/4 Lg.; Torque to 50/60 in. lbs.)
19	21091	1	Nylon Coupling
20	10528	1	Adapter Union
21	22033	1	Suction Line
22	11199	2	Needle Thrust Bearing (See note below)
23	10266	1	O-ring (1/4 x 3/8 x 1/16)
24	21272	1	Drive Gear
25	10303	1	O-ring (3/4 x 7/8 x 1/16)
26	10425	2	Compression Spring (3/8 O.D. x 3/4 Lg.)
27	20771	2	Poppet
28	40120	1	Pump Body
29	10427	1	Pipe Plug (1/8 NPTF)
30	10271	1	O-ring (11/16 x 1/2 x 3/32)
31	12389	1	Teflon Backup Washer
32	20849	1	Spool
33	23255	1	Spring Guide
34	10426	1	Compression Spring (1" O.D. x 1-13/16 Lg.)
35	23256	1	Spring Guide
36	21345	1	Filter Assembly

## NEEDLE BEARING INSTALLATION SPECIFICATIONS

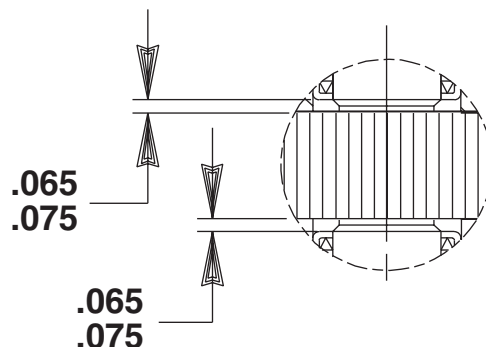

When replacing the needle bearings on the drive gear of the basic pump, the dimensions shown must be as specified.



# HIGH PRESSURE PUMP ASSEMBLY

6 PISTON -- 9/32 DIA.

SEE DIAGRAM  
ON REVERSE SIDE  
FOR IMPORTANT  
ASS'Y.  
INFORMATION

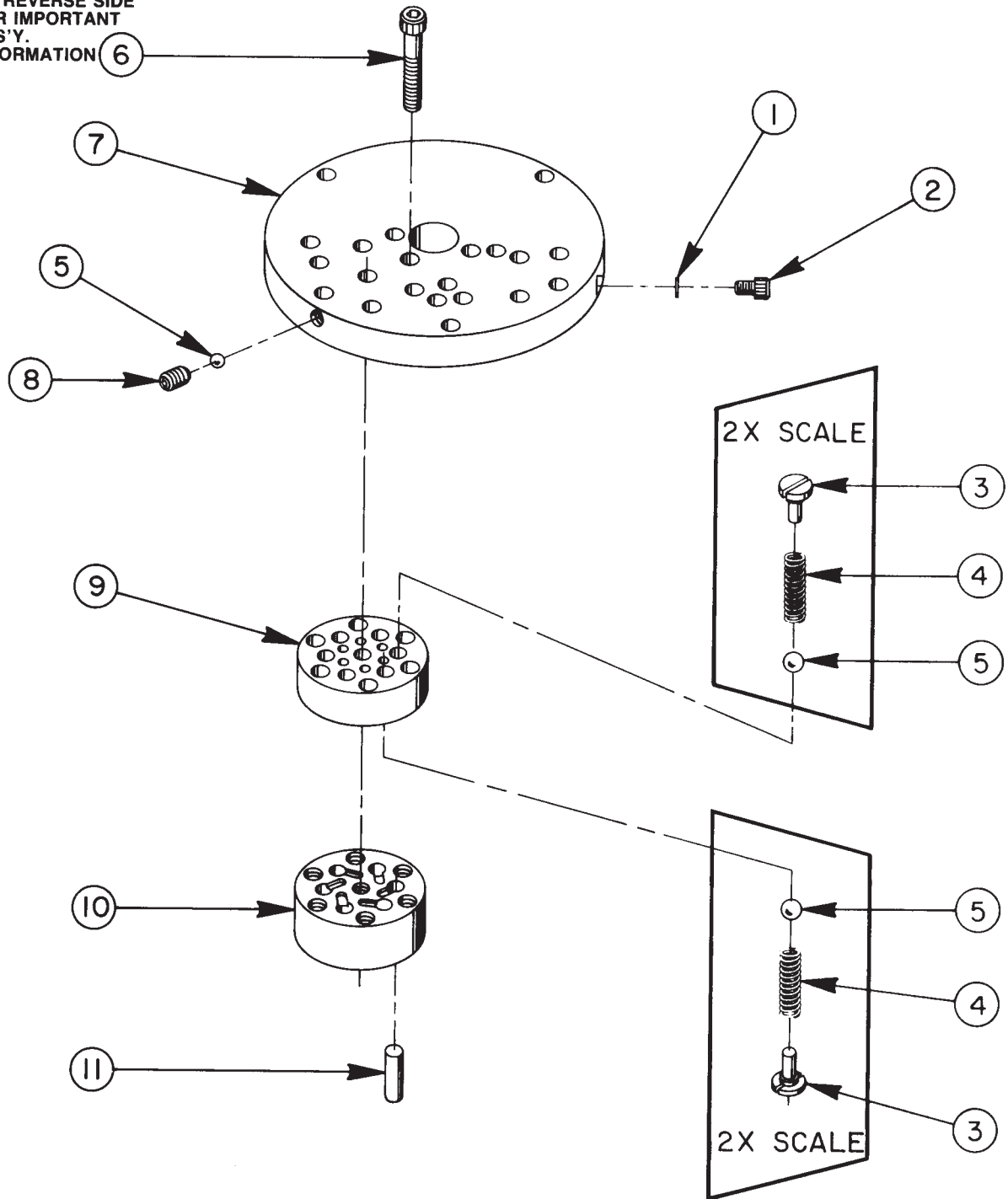

Item No.	Part No.	No. Req'd	Description
1	10442	1	Copper Washer (3/8 x 1/4 x 1/32)
2	10002	1	Soc. Hd. Cap Screw (1/4-20 UNC x 3/8 Lg.; Torque to 140/160 in. lbs.)
3	24549	12	Valve Guide
4	10445	12	Compression Spring (5/32 O.D. x 3/4 Lg.)
5	12223	13	Steel Ball (3/16 dia.)
6	10023	7	Soc. Hd. Cap Screw (1/4-28 UNF x 1-1/2 Lg.; Torque to 170/180 in. lbs. See note below.)
7	50411	1	Top Plate
8	10519	1	Soc. Set Screw (1/4-20 UNC x 3/8 Lg.; Torque to 65/70 in. lbs.)
9	41048	1	Valve Head
10	41063	1	Pump Barrel
11	21628	6	Piston

### BOLT TIGHTENING SEQUENCE

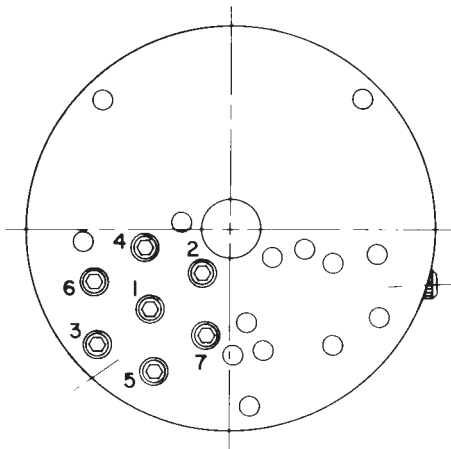

**NOTE: Assemble in sequence shown.  
Lubricate under head and on threads.  
Torque to 180 in. lbs.**