

MODEL B HYDRAULIC CYLINDER

Max. Capacity: 103.1 Tons At 10,000 PSI

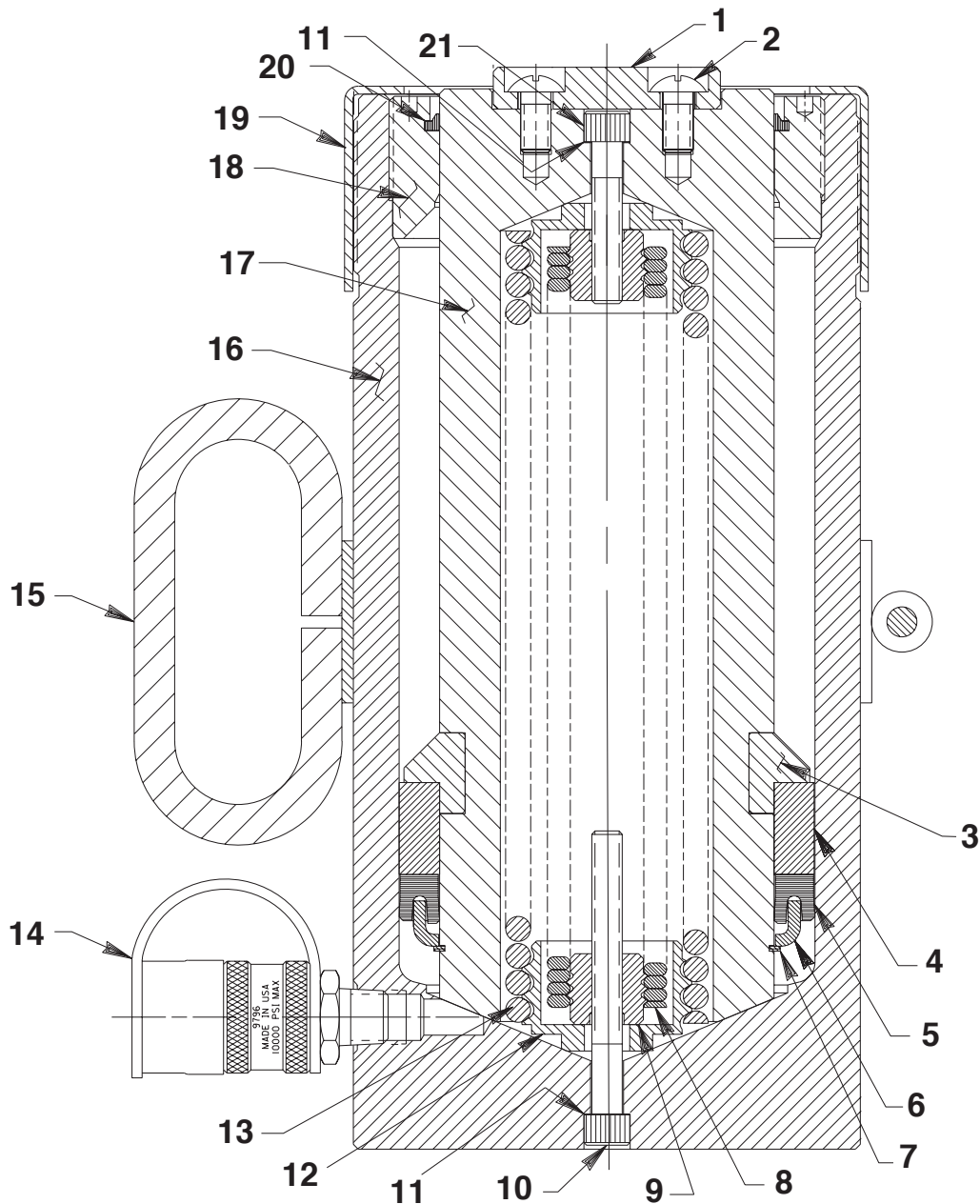

Parts List, Form No. 101436 Back sheet 1 of 2

Item No.	Part No.	No. Req'd	Description
1	36161	1	Ram Saddle (For all models except C10010-S; See sheet 2 of 2.)
2	16112	2	Machine Screw (3/8-16 UNC X 3/4 Lg.; Tighten securely)
3	36139	1 pr.	Keeper Ring
4	36135	1	Piston Head
5	*16122	1	U-cup
	†205707	1	U-cup
6	36137	1	Slip Retainer
7	*16111	1	Retaining Ring
8	201475	1	Extension Spring - Small (For 66001 & C1006C; See diagram below)
	201477	1	Extension Spring - Small (For C10010C & C10010-S; See diagram below)
9	201417	2	Spring Retainer (See diagram below)
10	16110	1	Cap Screw (3/8-16 UNC X 3-1/2 Lg.; Torque to 400/425 in. lbs.)
11	*†12042	2	Copper Washer (9/16 X 3/8 X 1/32)
12	36084	2	Spring Retainer (See diagram on sheet 2 of 2)
13	201474	1	Extension Spring - Large (For 66001 & C1006C; See diagram on sheet 2 of 2)
	201476	1	Extension Spring - Large (For C10010C & C10010-S; See diagram on sheet 2 of 2)
14	9796	1	Ram Half Coupler w/ Dust Cap (For all models except C10010-S)
	11127	1	Plug Fitting (For C10010-S)
15	420488OR9	1	Cylinder Lift Handle Assembly (For all models except C10010-S)
16	58535	1	Cylinder Body (For C1006C)
	58541	1	Cylinder Body (For C10010C)
	58623	1	Cylinder Body (For C1006C-JWI; [4] 1/2-13 UNC base mounting holes)
	59067	1	Cylinder Body (For C10010-S)
	59235	1	Cylinder Body (For 66001)
17	50833	1	Piston Rod (For 66001 & C1006C)
	50832	1	Piston Rod (For C10010C & C10010-S)
18	36136	1	Retainer Nut (Torque to 125/150 ft. lbs.)
19	42194	1	Thread Protector
20	*16113	1	Rod Wiper
	†205719	1	Rod Wiper
21	11531	1	Cap Screw (3/8-16 UNC X 2" Lg.; Torque to 400/425 in. lbs.)

PARTS INCLUDED BUT NOT SHOWN

*37782	1	Warning Decal
37782-CE	1	Warning Decal (For C1006C-PFAFF)
350973	1	Trade Name Decal (For C1006C)
350978	1	Trade Name Decal (For C10010C)
202173	1	Trade Name Decal (For C1006C-JWI & C10010-S)
252186	1	Trade Name Decal (For C1006C-PFAFF)
309219	1	Trade Name Decal (For 66001)

Part numbers marked with an asterisk (*) are contained in Standard Repair Kit No. 300112.

Part numbers marked with a dagger (†) are contained in Viton Seal Kit No. 300216.

SPRING & RETAINER ASSEMBLY

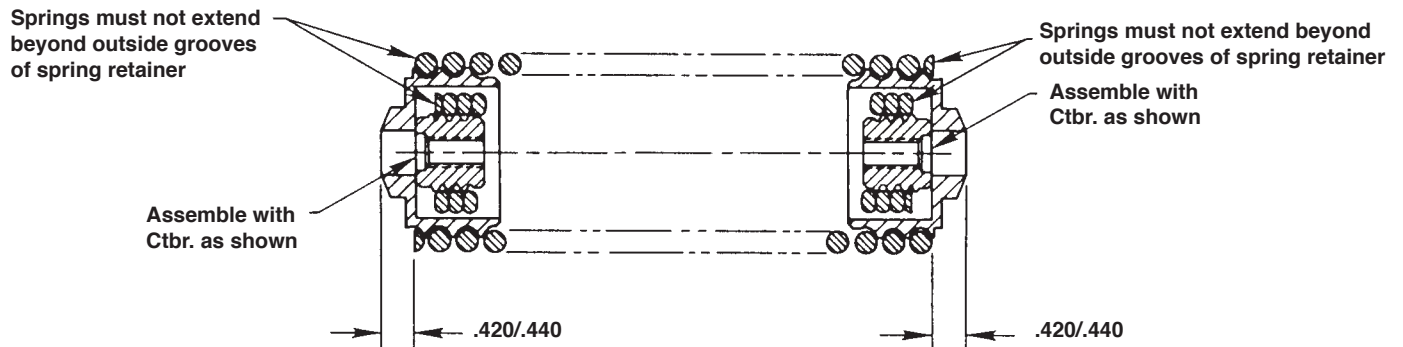

Refer to any operating instructions included with this product for detailed information about operation, testing, disassembly, reassembly, and preventive maintenance.

Items found in this parts list have been carefully tested and selected. **Therefore: Use only genuine Power Team replacement parts!**

Additional questions can be directed to our Technical Services Department.

TILT SADDLE CAP ASSEMBLY (FOR C10010-S ONLY)

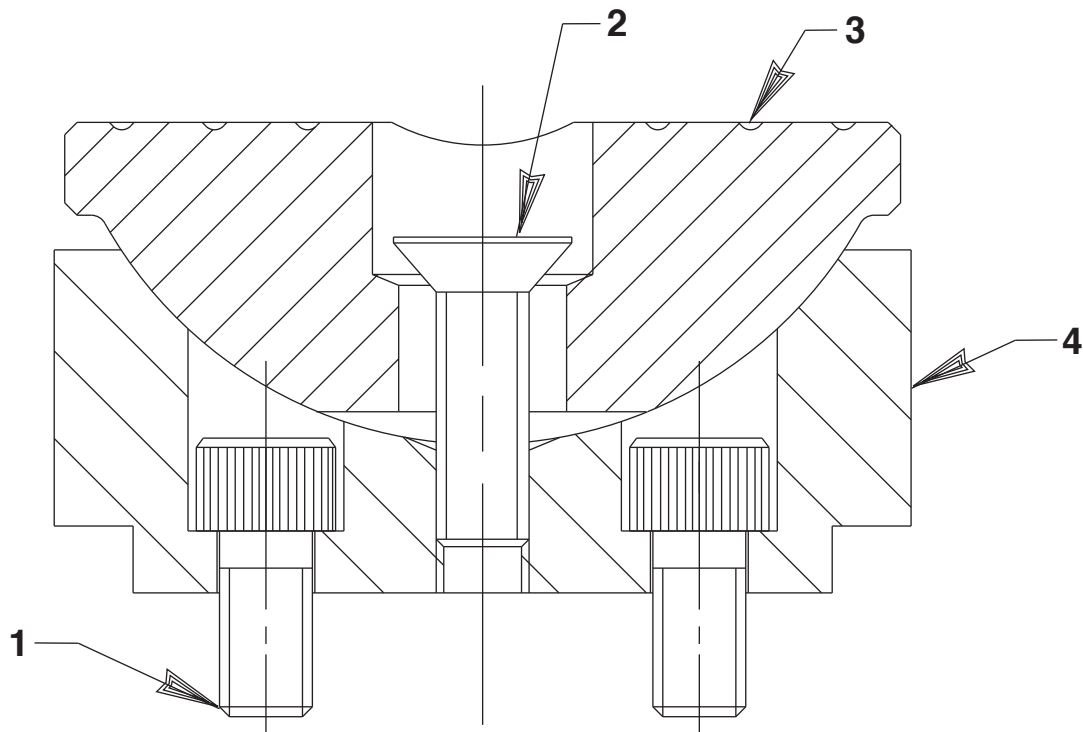

Item No.	Part No.	No. Req'd	Description
1	10464	2	Cap Screw (3/8-16 UNC X 3/4 Lg.; Torque to 320/340 in. lbs.)
2	250648	1	Screw
3	420370	1	Swivel Cap
4	421606	1	Tilt Saddle Base

ASSEMBLY INSTRUCTIONS

1. Mount tilt saddle base to cylinder piston with appropriate socket head cap screws (Item 1). Torque as specified.
2. Position swivel cap on base and tilt until lip on swivel cap contacts the base.
3. Thread in self-locking flat head screw. DO NOT overtighten. Swivel cap should swivel freely, and lip on swivel cap should always contact the base at maximum tilt angle. The lip is not intended to support the load, only to indicate the maximum tilt angle.