

PUMP MOUNTED VALVE SUBPLATE

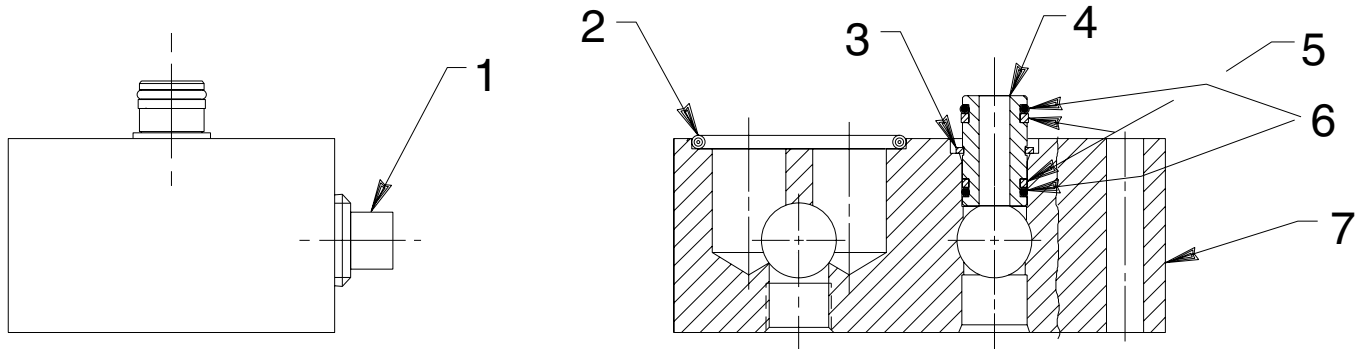

SPECIFICATIONS	
Max. Working Pressure	10,000 PSI
Max. Flow Rating	5 GPM
Port Sizes	3/8 NPTF

Item No.	Part No.	No. Req'd	Description
1	11127	2	Pressure Plug (3/8" NPTF)
2	10914	1	O-ring (1-3/8 X 1-3/16 X 3/32, -123)
3	251124	1	Retaining Ring (1/2 Shaft)
4	21094	1	Bushing
5	11863	2	Backup Washer (1/2 X 3/8 X 1/16, -012)
6	10268	2	O-ring (1/2 X 3/8 X 1/16, -012)
7	58224	1	Manifold Body

PARTS INCLUDED BUT NOT SHOWN

216234	4	Cap Screws (For mounting)
--------	---	---------------------------

SAFETY PRECAUTIONS



WARNING

- All WARNING statements must be carefully observed to help prevent personal injury.

Hydraulic Hose

- Before operating the pump, all hose connections must be tightened with the proper tools. Do not overtighten. Connections should only be tightened securely and leak-free. Overtightening can cause premature thread failure or high pressure fittings to split at pressures lower than their rated capacities.
- Should a hydraulic hose ever rupture, burst, or need to be disconnected, immediately shut off the pump and shift the control valve twice to release all pressure. Never attempt to grasp a leaking pressurized hose with your hands. The force of escaping hydraulic fluid could cause serious injury.
- Do not subject the hose to potential hazard such as fire, sharp surfaces, extreme heat or cold, or heavy impact. Do not allow the hose to kink, twist, curl, or bend so tightly that the oil flow within the hose is blocked or reduced. Periodically inspect the hose for wear, because any of these conditions can damage the hose and possibly result in personal injury.

Safety Precautions (Continued)

- Do not use the hose to move attached equipment. Stress can damage the hose and possibly cause personal injury.
- Hose material and coupler seals must be compatible with the hydraulic fluid used. Hoses also must not come in contact with corrosive materials such as creosote-impregnated objects and some paints. Consult the manufacturer before painting a hose. Never paint the couplers. Hose deterioration due to corrosive materials can result in personal injury.

Control Valve

- Do not allow the valve case pressure (as measured on the *return line at the subplate*) to exceed 500 PSI. Refer to case pressure check as detailed in the valve set-up procedure in these instructions.
- Do not exceed the pump, the control valve, or the cylinder's hydraulic pressure rating.

SUBPLATE MOUNTING PROCEDURE

1. Using the cap screws provided mount the valve and subplate to the pump as shown in Figure 1.
2. Apply Power Team HTS6 thread sealant to the external threads of the hydraulic components that will be attached.
3. Install a *temporary set-up* of a hydraulic gauge mounted to a tee adapter, directly into the oil return port of the subplate. See Figure 1.

NOTE: The valve is designed for a maximum *operating pressure* of 10,000 PSI. The return oil, which should be zero or under minimum pressure, is contained by the valve case and is not to exceed 500 PSI.

4. Connect the hydraulic hoses from the remote application to the subplate.
5. Recheck all hydraulic installation fittings. Then cycle the remote application several times. Check the pressure gauge installed on the return line and observe the return oil pressure as the remote valve is cycled through the advance, neutral (hold), and return positions.

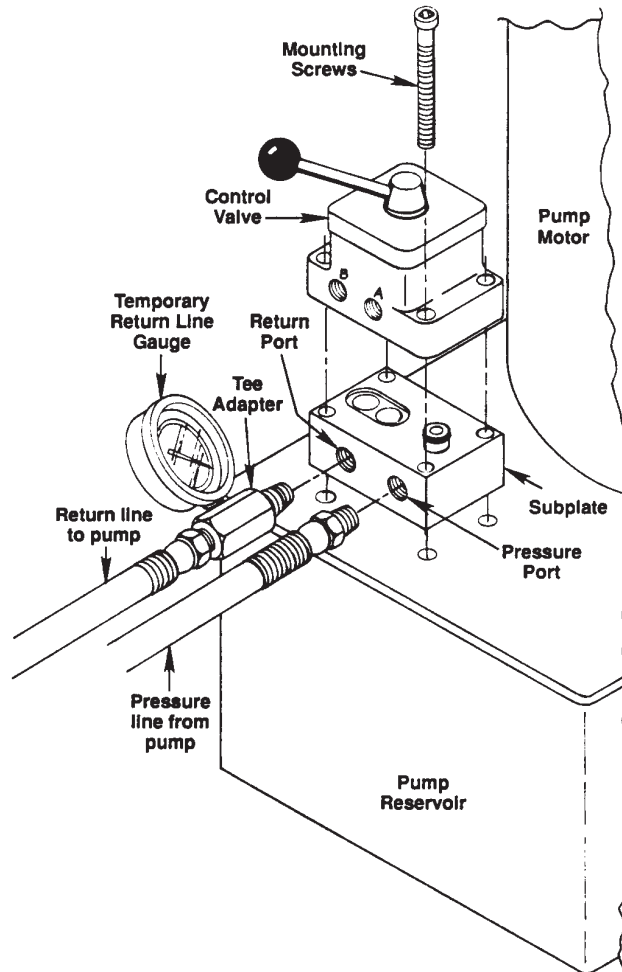

FIGURE 1

WARNING: Return line oil pressure at pump mounted valve subplate not to exceed 500 PSI. If return line pressure does exceed 500 PSI:

- Do not use quick couplers on the return line.
 - Eliminate as many bends and restrictions in the return line as possible.
6. If return line pressure is within the 500 PSI maximum limit, remove gauge and the adapter. Connect return line into return port.