

NUT SPLITTER

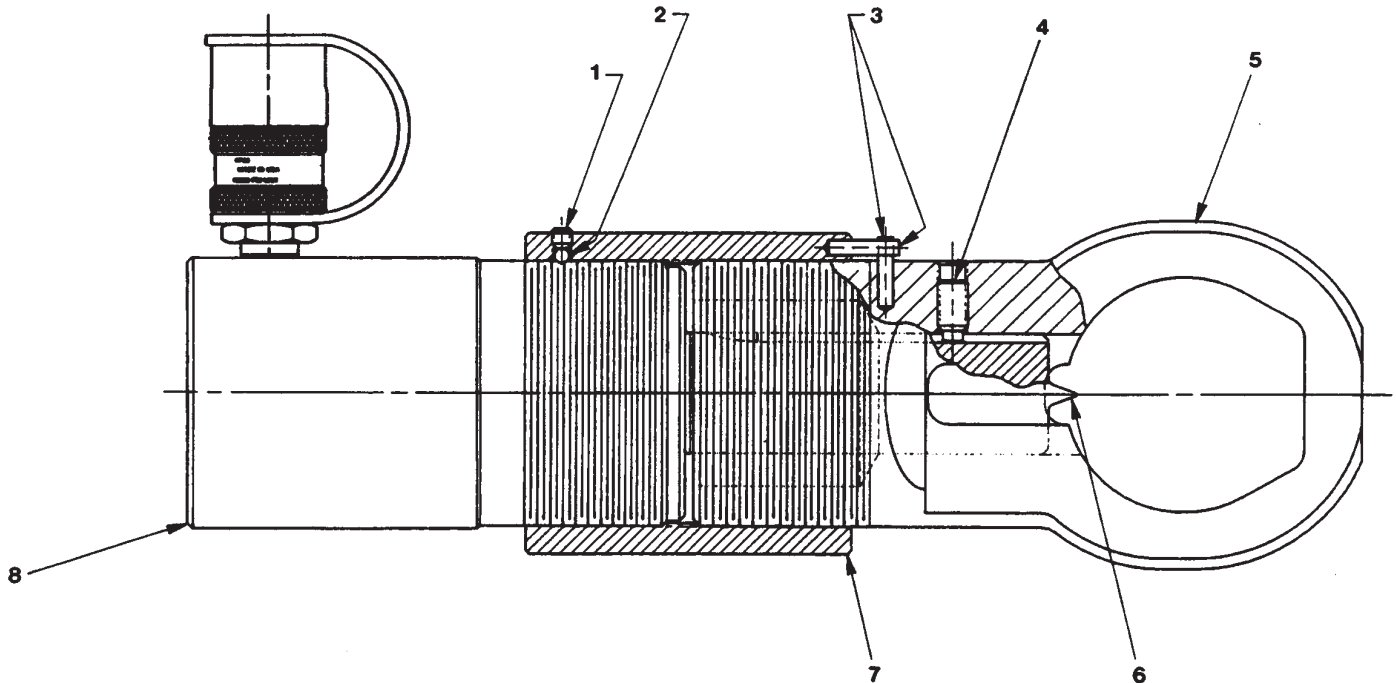

Item No.	Part No.	No. Req'd	Description
1	10136	1	Set Screw (1/4-20 UNC X 1/4 Lg.)
2	15528	1	Ball (3/16 dia.)
3	10549	2	Roll Pin
4	214125	1	Hex Socket Set Screw
5	53032	1	Frame
6	1U-9383	1	Blade (For 1U-9382)
	308022	1	Blade (For HNS225)
7	46962	1	Sleeve
8	C252C	1	Hydraulic Cylinder (See forms #100397 & #102397)

SAFETY PRECAUTIONS

! WARNING: To help prevent personal injury:

- Safety glasses must be worn at all times to help prevent eye injury.
- Never exceed the rated capacity of the Nut Splitter. Do not attempt to split nuts having a hex size greater than 2-1/4" or smaller than 1-1/8". Maximum square nut capacity is 1-1/2" sq; minimum is 1-1/8" sq.
- The blade must be positioned to insure that the entire thickness of the nut is cut in a single stroke.

IMPORTANT: To avoid possible equipment damage, do not use the Nut Splitter to cut flanged nuts.

OPERATING INSTRUCTIONS

1. Place the ring of the Nut Splitter around the nut to be removed. A flat of the nut must be against the flat side of the Nut Splitter ring. The blade must be centered and must span the entire thickness of the nut.
2. Advance the blade against a flat of the nut until the nut cracks. This will expand the threads of the nut to allow removal.
3. Retract the blade. In some cases, it may be possible to make a second cut directly opposite the first cut to completely separate the nut into halves for removal.

REPLACING THE BLADE IN THE NUT SPLITTER

1. Pull pin (#3) from the sleeve.
2. Loosen the set screws (#1 & #4). Remove the frame (#5) from the sleeve (#7), and remove the blade from the cylinder (#8).
3. Clean and lubricate all threads with general purpose lithium grease before reassembling.
4. Thread the new blade into the cylinder piston until the threads bottom out.
5. Thread the sleeve over the cylinder body until the threads bottom out.
6. Thread the frame into the sleeve until the frame bottoms out on the cylinder body.
7. Unscrew the frame (up to one turn) until the hole for the set screw (#4) lines up with the keyway in the blade. Tighten the set screw (#4) until it bottoms out on the blade and then back it out 1/4 turn.
8. Hold the cylinder, frame and blade while rotating the sleeve counterclockwise (as viewed from the frame end) until the hole for the roll pin (#3) is located just clockwise from the roll pin in the frame. Reassemble the roll pin into the sleeve.
9. Tighten set screw (#1) securely.

MAXIMUM CAPACITY OF THE NUT SPLITTER

Due to the various sizes and types of nuts, it is not practical to list maximum nut sizes for all applications of this tool. The following chart lists general applications based on test results and is not intended to show the only ways to use the tool. Contact Power Team Technical Services Department for questions involving applications not shown.

Nut Grade--English (Nut Class--Metric)	2 or A (5)	5 or B (9)	8 or C (10)	2H (12)
Hex Size	2-1/4 (55)	2-1/4 (55)	2-1/16 (46)	1-11/16 (36)
Bolt Size	1-1/2 (36)	1-1/2 (36)	1-3/8 (30)	1-1/8 (24)
Nut Thickness	1.500 (33.9)	1.281 (30.2)	1.171 (25.0)	.968 (20.9)

**Maximum square nut capacity: 1-1/2" sq.
(38) sq.**