

Operating Instructions for:

110-000051-1	4046-50-220	PA172	PE172A-OWENS
110-000051-3	4047	PA174	PE172S-KJ
4044	61253	PE17 Series	PE192
4044-50-110	61399	PE30-ATCO	PE194
4044-50-220	61463-CL	PE30-MAST	PE302-MAST
4044-SP	65703-CJJ	PE32-ATCO	PE322-MAST
4045	99150-B	PE32-MAST	YA404
4046	HE172	PE172-CCLUK	
4046-50-110	HE174	PE172-FS	

TWO STAGE HYDRAULIC PUMP

NOTE:

- Inspect the pump upon arrival.
- Read and carefully follow these instructions. Most problems with new equipment are caused by improper operation or installation.

IMPORTANT: Included in the literature bag are four (4) Self-tapping Screws (#209799). These screws are specifically required for attaching the plastic reservoir to the press or work station.

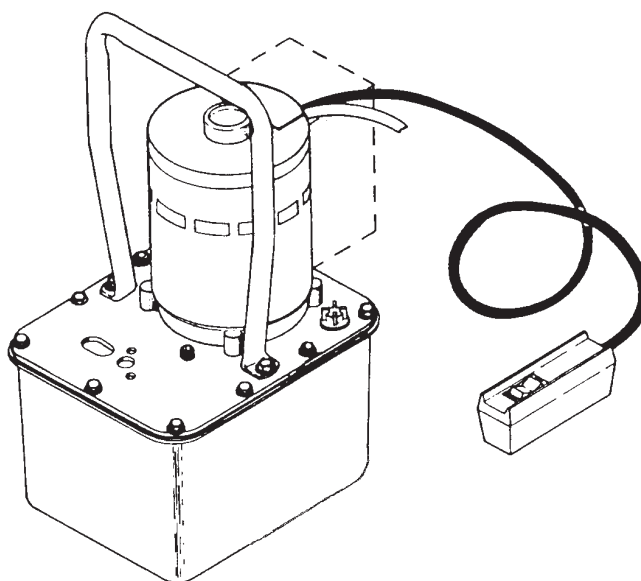

NOTE: These instructions cover several standard pumps. Some special units may appear different or have different specifications. Direct any questions to an appropriate Authorized Service Center or Technical Services Department. An electric model is shown in this figure.

**WARNING**

- All WARNING statements must be carefully observed to prevent personal injury.

General Operation

- Before operation the pump, all hose connections must be tightened with proper tools. Do not overtighten. Connections need only be tightened securely and leak-free. Overtightening may cause premature thread failure or may cause high pressure fittings to split at pressures lower than their rated capacities.
- Should a hydraulic hose ever rupture, burst, or need to be disconnected, immediately shut off the pump and shift the control valve twice to release all pressure. Never attempt to grasp a leaking hose under pressure with your hands. The force of escaping hydraulic fluid could cause serious injury.
- Do not subject the hose to potential hazard such as fire, extreme heat or cold, sharp surfaces, or heavy impact. Do not allow the hose to kink, twist, curl, or bend so tightly that the oil flow within the hose is blocked or reduced. Periodically inspect the hose for wear because any of these conditions can damage the hose and possibly result in personal injury.
- Do not use the hose to move attached equipment. Stress may damage the hose and possibly cause personal injury.
- Hose material and coupler seals must be compatible with the hydraulic fluid used. Hoses also must not come in contact with corrosive materials such as creosote-impregnated objects and some paints. Consult the manufacturer before painting a hose. Never paint the couplers. Hose deterioration due to corrosive materials may result in personal injury.

Pump

- Do not exceed the PSI hydraulic pressure rating noted on the pump name plate or tamper with the internal high pressure relief valve. Creating pressure beyond rated capacities may result in personal injury.
- Before replenishing the oil level, retract the system to prevent overfilling the pump reservoir. An overfill may cause personal injury due to excess reservoir pressure created when cylinders are retracted.

Note: Shaded areas reflect last revision(s) made to this form.

Sheet No. 1 of 4

Rev. 3 Date: 29 Mar. 1999

Safety Precautions (Continued)

Cylinder

- Do not exceed rated capacities of the cylinders. Excess pressure may result in personal injury.
- Do not set poorly-balanced or off-center loads on a cylinder. The load may tip and cause personal injury.

Air Supply

- Shut off and disconnect the air supply when the pump is not in use or before breaking any connection in the system.

Electrical Supply

- Do not use an ungrounded (two-prong) extension cord.
- Avoid conditions which could create an electrical hazard.
- If the power cord is damaged or wiring exposed, replace or repair immediately.
- Check the voltage rating on the pump motor name plate to be certain the outlet you are using is of the proper voltage.
- Correct voltage is required for pump to operate properly.
- Low voltage may cause the following: ■ overheated motor; ■ motor fails to start under load; ■ motor surging when trying to start; ■ motor stalls before maximum pressure is reached.
- Always check the voltage at the motor with the pump running at full pressure.
- Never run the motor on long, light gauge extension cords.
- Low voltage = 10% less than name plate voltage.
- Line voltage for all permanent magnet motors (PE19 series) must not exceed 120 volts AC.

SET-UP AND OPERATION

Electric Motor



WARNING: To help avoid possible personal injury,

- Any electrical work must be done by a qualified electrician.
- Disconnect the power supply before removing the motor casing cover or performing repairs or maintenance.
- Changing the voltage on this unit is an involved, and if improperly performed, hazardous procedure. Consult the manufacturer for specific information before attempting any rewiring.

Hydraulic Set-up

1. Clean the areas around the oil ports of the pump and hydraulic cylinders.
2. Inspect the threads and fittings for signs of wear or damage and replace as needed. Clean all hose ends, couplers, and union ends.
3. Remove the plastic thread protectors from the hydraulic outlets. Connect the hose assembly to the valve and couple the hose to the cylinder.
4. Seal all pipe connections with pipe sealant. Teflon tape can be used to seal hydraulic connections provided only one layer of tape is used. Apply the tape carefully to prevent it from being pinched by the coupler and broken off inside the pipe end. Any loose pieces of tape could travel through the system and obstruct the flow of oil or cause jamming of precision-fit parts.

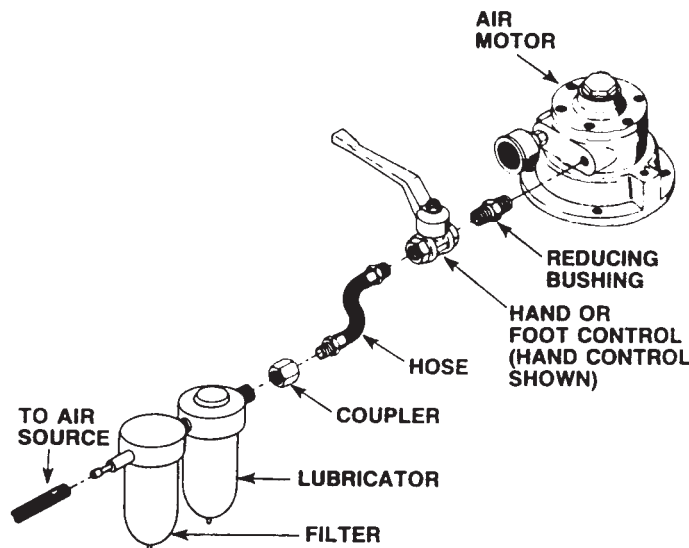

**RECOMMENDED
AIR LINE HOOK-UP**

Air Motor Set-up

Remove the thread protector from the air inlet and install the air supply fittings (not included) as shown at right. Air supply must be minimum 50 CFM and 80 PSI, with 100 PSI maximum.

Filling the Reservoir

NOTE: The pump is shipped without oil in the reservoir. Oil is included in a separate container.

1. Thoroughly clean the area around the filler cap with a clean cloth to prevent contamination of the oil by foreign particles.
2. Remove the filler cap and insert a clean funnel with filter. Reservoir may be filled to within 1" of the top cover with all cylinders retracted. Replace filler cap and check to see that the breather-hole in the cap is open. **Note: If oil foaming becomes a problem, reduce the oil level to 2" below the cover plate.**

Valve Operation

2-Position, 2-Way Manual Valves used with Single-acting Cylinders

1. To build pressure, turn the valve control handle counterclockwise (CCW).
2. Start the pump by pressing the remote motor control ON/OFF switch. **NOTE: Oil advances the cylinder when the unit is activated.**
3. When the cylinder has advanced to the desired position, release the remote motor control ON/OFF switch.
4. To retract the cylinder, turn the valve control clockwise (CW).

NOTE: The valve works the same as the manifold if the pump is operated with the valve in the RETURN position. In this position, the cylinder advances when the pump is running and retracts when the motor is stopped.

When the valve is in the HOLD position, the cylinder advances when the pump is running and holds when the motor is stopped. The cylinder can be retracted by moving the valve to the RETURN position.

Manifold Assembly used with Single-acting Cylinders or Remote Valves

1. Start the pump by pressing the remote motor control ON/OFF switch. **NOTE: Oil advances the cylinder when the unit is activated.**
2. When the cylinder has advanced to the desired position, release the remote motor control ON/OFF switch. The cylinder will retract.

Tandem Center 4-Way Control Valve used with Double-acting Cylinders

1. Place the valve control lever in the NEUTRAL or hold position.
2. Start the pump by pressing the remote motor control ON/OFF switch.
3. Advance the cylinder by shifting the valve control lever to the ADVANCE position.
4. When the cylinder has advanced to the desired position, release the remote motor control ON/OFF switch. **NOTE: The cylinder momentarily loses pressure during the shifting process.**
5. Retract the cylinder by shifting the valve control lever to the RETRACT position.

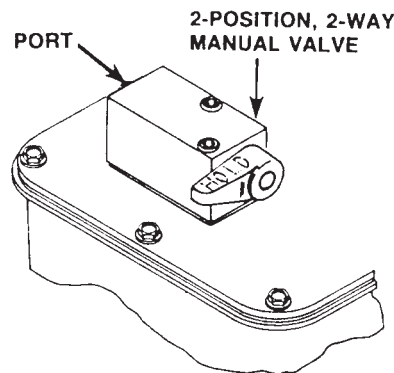

FIGURE 1

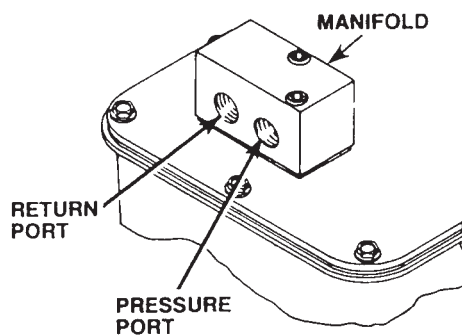

FIGURE 2

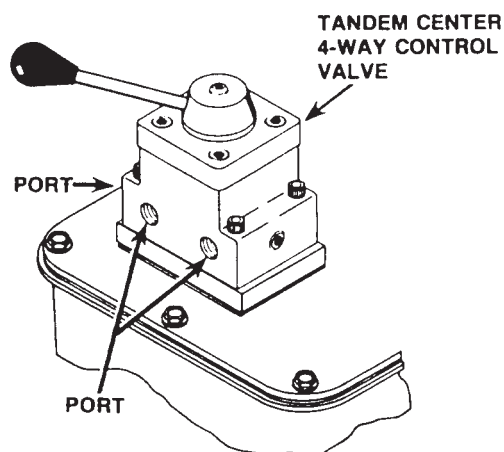

FIGURE 3

PREVENTIVE MAINTENANCE



WARNING: To help avoid possible personal injury,

- Disconnect the pump from the poser supply before performing maintenance or repair procedures.
- Repairs and maintenance should be performed in a dust-free area by a qualified technician.

Bleeding Air from the System

Air can accumulate in the hydraulic system if the reservoir oil level has been permitted to get too low. This air causes the cylinder to respond in an unstable or slow manner. To remove the air:

1. Position hydraulic cylinder(s) on their sides with the couplers located upward and at a lower level than the pump.
2. Remove any load from the cylinder(s), and cycle the hydraulic system through several cycles (fully extend and retract the cylinders).

Hydraulic Fluid Level

1. Check the oil level in the reservoir after each 10 hours of use. Due to the very limited amount of oil required by the typical hydraulic cylinder(s) used with this pump, the oil level is considered adequate when the reservoir is partially full. Maximum capacity is when the oil is 1-1/2" below the cover plate with all cylinders retracted.
2. When adding oil, use an approved, high-grade hydraulic oil (215 SSU @ 100°F). Retract the cylinders and disconnect the power supply. Clean the area around the filler plug, remove the plug, and insert a clean funnel with filter.
3. The frequency of oil changes will depend upon the general working conditions, severity of use, and overall cleanliness and care given the pump. Three hundred hours of use under general shop conditions is considered a standard change interval. Drain, flush, and refill the reservoir with an approved, high-grade hydraulic oil (215 SSU @ 100°F).

Lubrication (Air Driven Motor only)

If the pump is operated on a continuous duty cycle or at maximum speeds for extended periods, an automatic air line oiler should be installed in the air inlet line as close to the pumping unit as possible. Set the unit to feed 1 drop of oil per minute (one drop for every 50-75 CFM of air) into the system, or refer to the air pump manufacturer's instructions. Use SAE #10 oil.

Draining and Flushing the Reservoir

IMPORTANT: Clean the pump exterior before the pump interior is removed from the reservoir.

1. Remove the ten screws that fasten the motor and pump assembly to the reservoir.

IMPORTANT: Do not damage the gasket or bump the filter or pressure regulating valves when lifting the pump and motor off the reservoir. See Figures 4 & 5.

2. Drain oil and clean the inside of the reservoir. Fill with a suitable nonflammable flushing oil. Rinse the filter clean.
3. Place the pump and motor assembly back onto the reservoir and secure with four of the ten screws. Assemble the screws in opposite corners of the housing.

IMPORTANT: Connect a hose to the advance/retract port of the pump manifold. Place the other end of the hose into the oil filler plug hole.

4. Run the pump for several minutes. Then disconnect the motor and pump assembly, and drain and clean the inside of the pump reservoir.
5. Fill the reservoir to 1-1/2" below the cover plate with an approved, high-grade hydraulic oil. Place the pump and motor assembly (with gasket) onto the reservoir. Thread in ten screws and tighten securely and evenly.

Maintenance and Cleaning

1. Keep the pump's outer surface as free from dirt as possible.
2. Seal all unused couplers with thread protectors.
3. Keep all hose connections free of dirt and grime.
4. The breather-hole in the filler cap must be clean and unobstructed at all times.
5. Equipment connected to the pump must be kept clean.
6. Use only an approved, high-grade hydraulic oil in this pump. Change as recommended (approx. every 300 hours).
7. Periodically lubricate the electric pump motor.

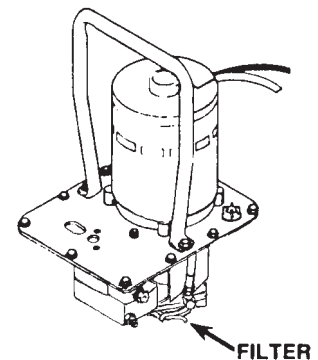

FIGURE 4

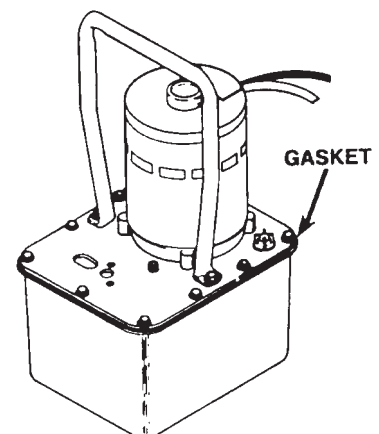

FIGURE 5

TROUBLE-SHOOTING GUIDE



WARNING: To help avoid possible personal injury,

- All repair work or trouble-shooting must be done by qualified personnel familiar with this equipment.
- Use the proper gauges and equipment when trouble-shooting.

NOTE:

- Depending on the type of pump, it is often best to check for leaks by using a hand pump and applying pressure to the suspect area without the motor running. Watch for leaking oil and follow it back to its source.
- Plug the outlet ports of the pump when checking for leakage to determine if the leakage is in the pump or if it is in the cylinder or tool.
- Refer to your pumps parts list and the following hydraulic schematic when using this trouble-shooting guide.

HYDRAULIC SCHEMATIC

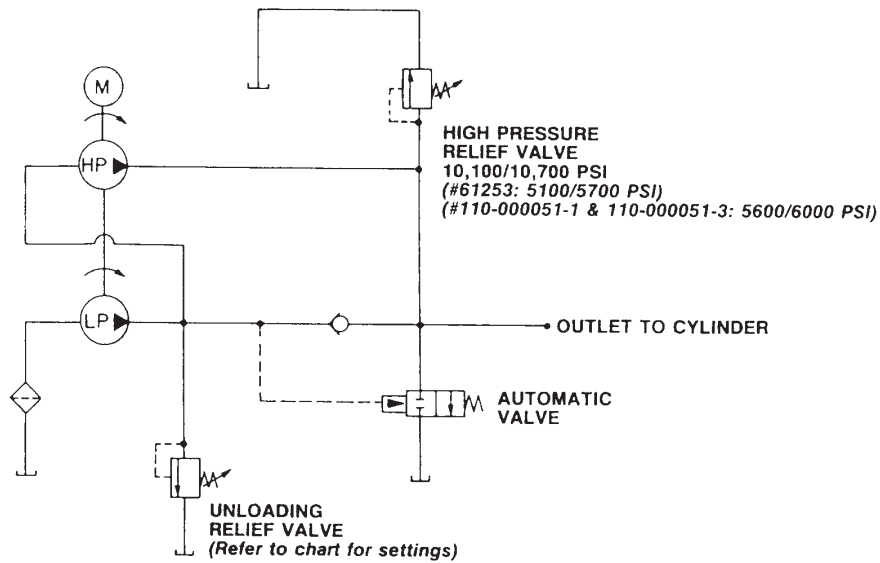

Unloading valve setting (measured at low pressure pump hose)	230/290 PSI	260/320 PSI	310/370 PSI	330/350 PSI
PUMP PART NUMBER	110-000051-3 110-000051-1 4044 4044-50-110 4044-50-220 4044-SP 4046 4046-50-110 4046-50-220 99150-B HE172 HE174 PE17 SERIES PE172A-OWENS PE172S-KJ PE192 PE192 YA404 PE30-MAST PE30-ATCO PE32-MAST PE32-ATCO PE302-MAST PE322-MAST 65703-CJJ 61463-CL PE172-CCLUK	4045 4047 PA172 PA174	61253	61399

Operating Instructions, Form No. 102503, Back sheet 3 of 4

PROBLEM	CAUSE	SOLUTION
Motor does not run	<ol style="list-style-type: none">1. Unit is not plugged in.2. No voltage supply.3. Broken lead wire or defective power cord plug.4. Defective motor.	<ol style="list-style-type: none">1. Plug in unit.2. Check line voltage.3. Replace defective parts.4. Replace or repair motor.
Pump is not delivering oil or delivers only enough oil to advance cylinder(s) partially or erratically	<ol style="list-style-type: none">1. Oil level too low.2. Air in system.3. Dirt is in pump or filter is plugged.4. Cold oil or oil is too heavy (hydraulic oil is of a higher viscosity than necessary).5. Relief valve or low pressure unloading valve out of adjustment.6. Sheared drive shaft key(s).7. Motor rotating in wrong direction.	<ol style="list-style-type: none">1. Fill reservoir to 1-1/2" below the cover plate, maximum.2. Bleed the system.3. Pump filter should be cleaned and, if necessary, pump should be dismantled and all parts inspected and cleaned.4. Change to lighter oil.5. Readjust as needed.6. Replace.7. Reverse rotation.
Pump will not build full pressure	<ol style="list-style-type: none">1. Faulty pressure gauge.2. Check for external leakage.3. Inspect the pump for internal leakage.4. Sheared key(s).5. High pressure pump inlet or outlet ball checks in the pump are leaking.6. Inadequate air pressure (air motor only).	<ol style="list-style-type: none">1. Calibrate gauge.2. Seal any faulty pipe fittings with pipe sealant.3. Same procedure as above but for leaks around the entire inner mechanism. If there are no visible leaks the low-to-high pressure ball check may be leaking. Remove all parts. Inspect the check body for any damage to the seat areas. Clean and reseat if necessary. Inspect the ball for damages and replace if necessary, then reassemble.4. Replace.5. Reseat or replace valve head.6. Increase air pressure.
Automatic valve will not build full pressure	<ol style="list-style-type: none">1. Unloading pressure is too low.2. Defective or oversize seat on automatic valve.	<ol style="list-style-type: none">1. Increase unloading pressure per chart, sheet 3 of 4.2. Replace ball and seat.
Electric motor cuts out	<ol style="list-style-type: none">1. Extension cord is too long and/or not of sufficient gauge.2. Faulty motor.3. Overheated motor can trip circuit breaker in shop power panel.	<ol style="list-style-type: none">1. Replace.2. Replace and repair.3. Allow motor to cool, reset circuit breaker located in shop power panel.

PROBLEM	CAUSE	SOLUTION
Foaming oil	<ol style="list-style-type: none"> 1. Oil being splashed by counter weight. 	<ol style="list-style-type: none"> 1. Lower oil level to approximately 1-1/2" below the cover plate.
Cylinder(s) will not retract	<ol style="list-style-type: none"> 1. Check the system pressure; if the pressure is zero, the control valve is releasing pressure and the problem may be in the cylinder(s), mechanical linkage connected to cylinder(s), or quick-disconnect couplings. 2. Inadequate air pressure (air motor only). 	<ol style="list-style-type: none"> 1. Check the cylinders for broken return springs and check couplers to ensure that they are completely coupled. Occasionally couplers have to be replaced because one check does not stay open in the coupled position. 2. Increase air pressure.
Pump delivers excess oil pressure	<ol style="list-style-type: none"> 1. Pressure gauge is not accurate. 2. Relief valve not properly set. 	<ol style="list-style-type: none"> 1. Calibrate gauge. 2. Reset the relief valve.
Automatic vale will not release pressure	<ol style="list-style-type: none"> 1. Sticking piston. 2. High pressure oil is leaking past the low-to-high pressure check. This oil leaks back to the piston in the automatic valve, keeping the piston closed. 	<ol style="list-style-type: none"> 1. Remove, clean and polish. 2. Seat the ball check. Inspect and replace any faulty components.

ELECTRICAL SCHEMATICS

!
WARNING

To help avoid personal injury, all electrical work must be done by a qualified electrician.

North American & International Color Codes

Conductors	North American	International
Line	Black.....	Brown
Neutral	White	Blue
Ground	Green	Green/Yellow

110 V., 60 Hz./115 V., 50 Hz.

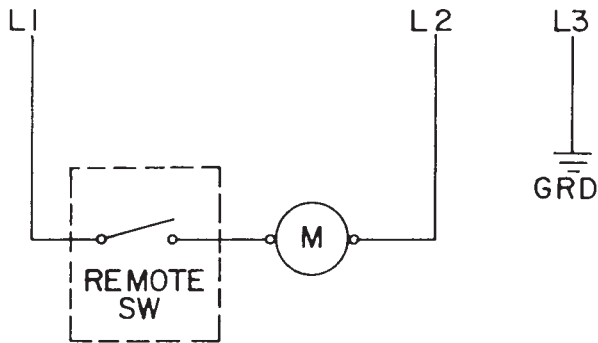

115 V., 50/60 Hz.
for PE192 & PE194

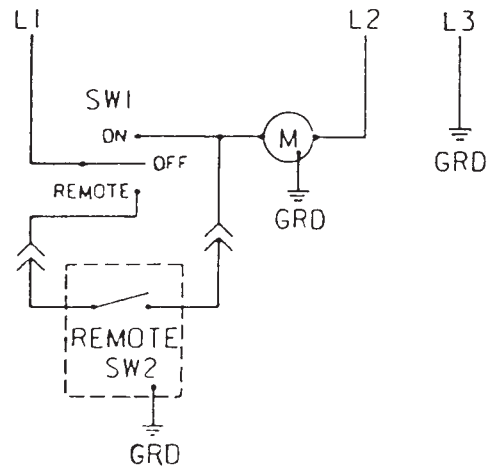

220 V., 50 HZ.

