



SPX Corporation
5885 11th Street
Rockford, IL 61109-3699 USA

Tech. Services: (800) 477-8326
Fax: (800) 765-8326
Order Entry: (800) 541-1418
Fax: (800) 288-7031

Internet Address:
<http://www.powerteam.com>

Form No. 102947

Parts List and
Operating Instructions
for:

J24T
J55T
J106T

HYDRAULIC TOE JACK

Part Number J24T Maximum Capacity: 2 Ton
Part Number J55T Maximum Capacity: 5 Ton
Part Number J106T Maximum Capacity: 10 Ton

Read and carefully follow the warnings and operating instructions before using this jack. Most problems with new equipment are caused by improper operation or setup.

NOTE: Inspect the jack upon arrival. The carrier, not the manufacturer, is responsible for any damage resulting from shipment.

SAFETY PRECAUTIONS



WARNING: To help prevent personal injury or damage to equipment,

- Do not exceed the maximum load capacity of the jack.
- Do not add additional load to a lifted load.
- Do not use in unstable or hazardous positions.
- Unit must be used on flat surfaces able to carry the load.
- Keep clear of lifted loads.
- The load must be stable during lifting. An unstable load may cause the jack or load to slip.
- Do not use the jack(s) if damaged, altered, or in poor condition.
- Do not lift people or loads with people on them.
- This hydraulic jack is for professional use only and should be used only by persons trained in its use.
- Do not lift at the end of the toe. Fully engage the load with the toe.
- Use only Power Team hydraulic fluid in this unit.
- Do NOT, under any circumstances, tamper with the adjustment of the jack's internal relief valve screw. To do so may cause the jack to fail.
- Read operating instructions and A.N.S.I. B30.1 safety code for jacks.
- The owner of the jack must ensure that all safety-related decals are maintained and replaced as they become hard to read.
- This guide cannot cover every situation, so always do the job with safety first.

OPERATING INSTRUCTIONS

IMPORTANT: Do not carry the jack by the jacking lever.

Lifting a Load

1. Position the load on the toe of the jack.



WARNING: Do not lift a load on the end of the toe. Fully engage the load with the toe.

IMPORTANT: When lifting by the toe, wedge the head of the jack on the load to avoid bending the column.

2. Turn the release valve knob in a clockwise direction until it is snug.
3. Pump the jacking lever in an up and down motion.

Lowering a Load

1. Slowly loosen the release valve knob by turning it in a counterclockwise direction. The more the knob is loosened, the faster the load will be lowered. To stop the jack from lowering a load, tighten the release valve knob by turning it in a clockwise direction.

PREVENTIVE MAINTENANCE

IMPORTANT: The greatest single cause of failure in hydraulic units is dirt. Keep the jack clean and well lubricated to prevent foreign matter from entering the system. If the jack has been exposed to rain, snow, sand, or grit, it must be cleaned before it is used.

1. When the jack is not in use, keep the piston and pump rods fully retracted. Store the jack on its base and in a well protected area where it will not be exposed to corrosive vapors, abrasive dust, or any other harmful elements.
2. Visually inspect the jack before each use. Take corrective action if any of the following problems are found:
 - a. Cracked or damaged housing
 - b. Excessive wear, bending, or other damage
 - c. Leaking hydraulic fluid
 - d. Scored or damaged piston rod
 - e. Incorrectly functioning swivel heads or adjusting screws
 - f. Loose hardware
 - g. Modified or altered equipment

TROUBLE-SHOOTING GUIDE

Repair procedures must be performed in a dirt-free environment by qualified personnel who are familiar with this equipment.

| TROUBLE | CAUSE | SOLUTION |
|---|---|--|
| Erratic Action | <ol style="list-style-type: none"> 1. Air in system 2. Viscosity of oil too high 3. Internal leakage in cylinder 4. Cylinder sticking or binding | <ol style="list-style-type: none"> 1. With jack sitting on its base and ram retracted, bleed air by opening release valve. Pump for 10 seconds. 2. Change to lower viscosity oil. 3. Replace worn seals. Check for excessive contamination or wear. 4. Check for dirt, gummy deposits, or leaks. Check for misalignment, worn parts, or defective seals. |
| Jack does not advance | <ol style="list-style-type: none"> 1. Release valve is open 2. Low/no oil in reservoir 3. Air-locked system 4. Load is above capacity of system | <ol style="list-style-type: none"> 1. Close release valve 2. Fill with oil and bleed system 3. Bleed the system 4. Use correct equipment |
| Jack only extends partially | <ol style="list-style-type: none"> 1. Reservoir is low on oil 2. Piston rod is binding | <ol style="list-style-type: none"> 1. Fill reservoir 2. Check for dirt, gummy deposits, or leaks. Check for misalignment, worn parts, or defective seals. |
| Jack advances slowly | <ol style="list-style-type: none"> 1. Pump not working correctly 2. Leaking seals | <ol style="list-style-type: none"> 1. Rework pump 2. Replace seals |
| Jack advances but doesn't hold pressure | <ol style="list-style-type: none"> 1. Cylinder seals are leaking 2. Pump check valve not working correctly 3. Overload valve leaking or not adjusted correctly | <ol style="list-style-type: none"> 1. Replace seals 2. Clean/replace check valve 3. Replace/adjust overload valve |
| Jack leaks oil | <ol style="list-style-type: none"> 1. Worn or damaged seals | <ol style="list-style-type: none"> 1. Replace seals |
| Jack will not retract or retracts slowly | <ol style="list-style-type: none"> 1. Release valve is closed 2. Cylinder damaged internally 3. Reservoir too full | <ol style="list-style-type: none"> 1. Open release valve 2. Send jack to authorized service center for repair 3. Drain oil to correct level |

PARTS LIST FOR 2 TON JACK (J24T)

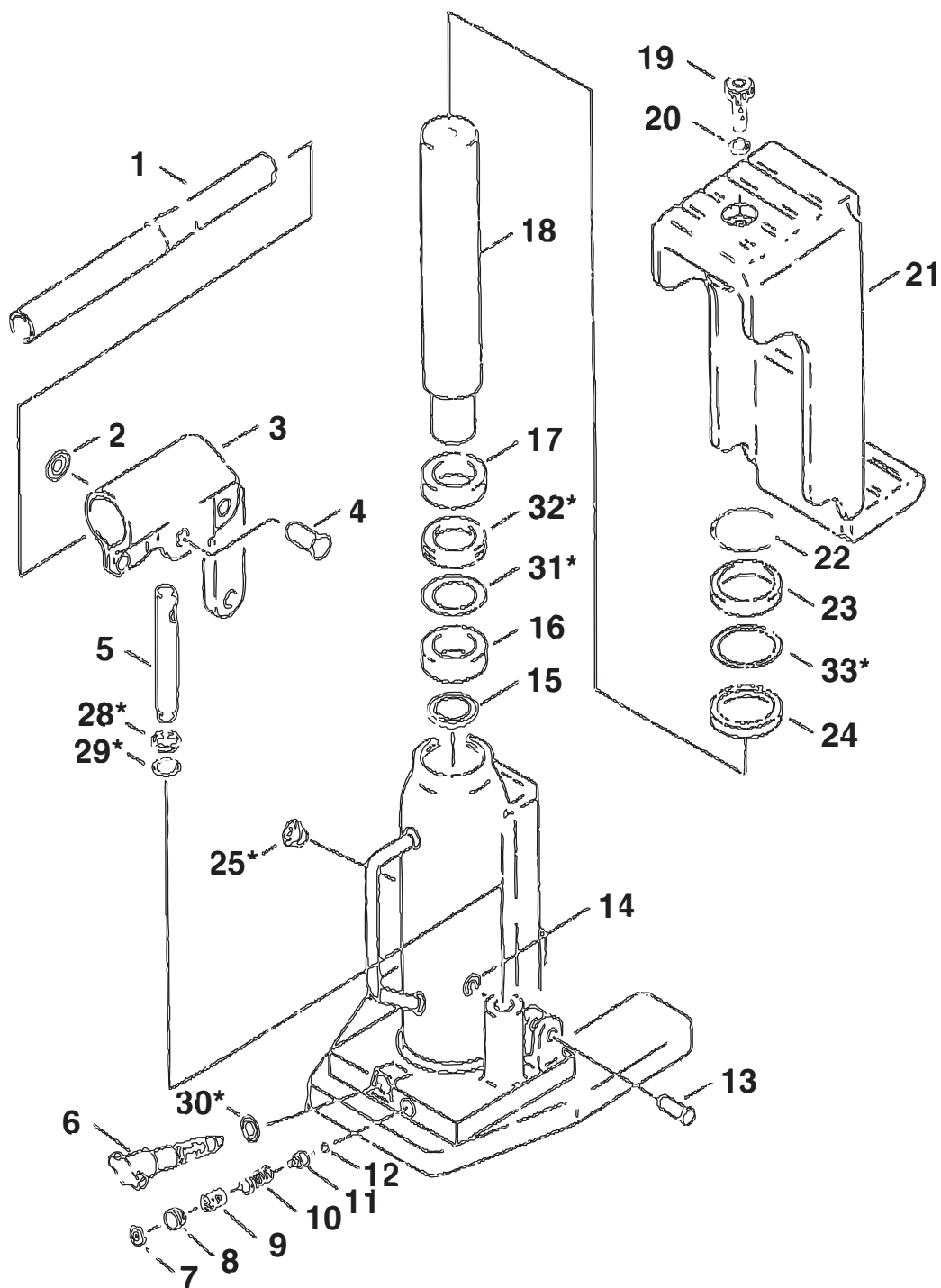

* = Parts marked with an asterisk (*) are in Repair Kit No. J24T-26.

| Item No. | Part No. | No. Req'd | Description |
|----------|----------|-----------|------------------------------|
| 1 | J24T-1 | 1 | Handle |
| 2 | J24T-2 | 1 | Snap Ring |
| 3 | J24T-3 | 1 | Handle Socket Assembly |
| 4 | J24T-4 | 1 | Pump Plunger Pin |
| 5 | J24T-5 | 1 | Pump Plunger |
| 6 | J24T-6 | 1 | Release Assembly |
| 7 | J24T-7 | 1 | Safety Valve Push Nut |
| 8 | J24T-8 | 1 | Safety Valve Plug |
| 9 | J24T-9 | 1 | Safety Valve Adjusting Screw |
| 10 | J24T-10 | 1 | Safety Valve Spring |
| 11 | J24T-11 | 1 | Safety Valve Ball Guide |
| 12 | J24T-12 | 1 | Safety Valve Ball |
| 13 | J24T-13 | 1 | Pump Stay Pin |
| 14 | J24T-14 | 1 | Snap Ring |
| 15 | J24T-15 | 1 | Ram Guide Ring Stopper |
| 16 | J24T-16 | 1 | Ram Guide Ring |
| 17 | J24T-17 | 1 | Ram Packing Guide |
| 18 | J24T-18 | 1 | Ram |
| 19 | J24T-19 | 1 | Bolt |
| 20 | J24T-20 | 1 | Washer |
| 21 | J24T-21 | 1 | Hanger |
| 22 | J24T-22 | 1 | Snap Ring |
| 23 | J24T-23 | 1 | Stuffing Ring |
| 24 | J24T-24 | 1 | Stopper Ring |
| 25 | *J24T-25 | 1 | Filler Plug |
| 28 | *J24T-28 | 1 | Pump Backup Ring |
| 29 | *J24T-29 | 1 | Pump Packing |
| 30 | *J24T-30 | 1 | Release Packing |
| 31 | *J24T-31 | 1 | Ram Packing |
| 32 | *J24T-32 | 1 | Ram Backup Ring |
| 33 | *J24T-33 | 1 | Cylinder Packing |

PARTS INCLUDED BUT NOT SHOWN

| | | |
|---------------|---|-------|
| 421686 | 1 | Decal |
|---------------|---|-------|

Part numbers marked with an asterisk (*) are contained in Repair Kit No. J24T-26.

PARTS LIST FOR 5 TON JACK (J55T)

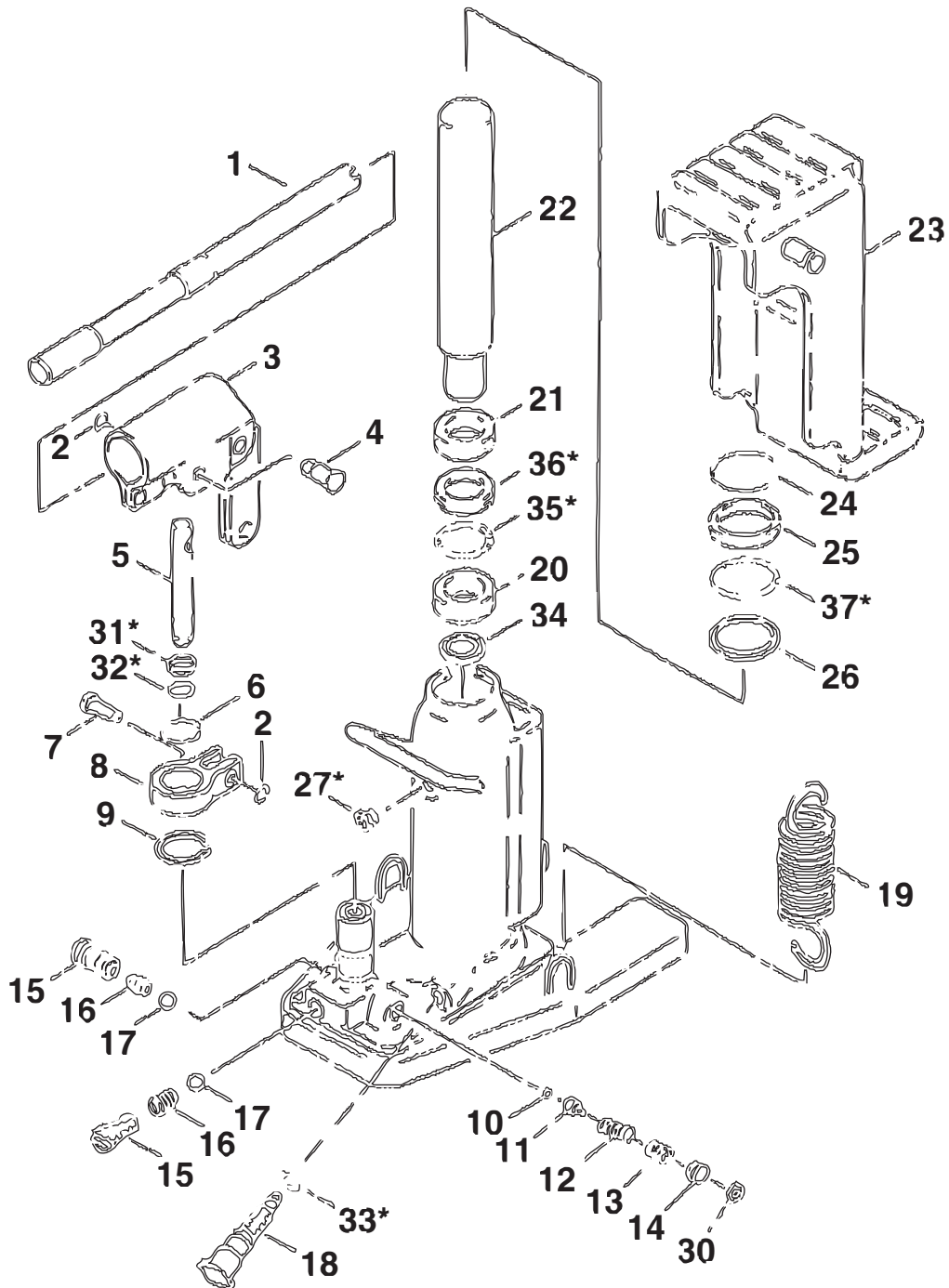

* = Parts marked with an asterisk (*)
are in Repair Kit No. J55T-28.

| Item No. | Part No. | No. Req'd | Description |
|----------|----------|-----------|------------------------------|
| 1 | J55T-1 | 1 | Handle |
| 2 | J55T-2 | 1 | Snap Ring |
| 3 | J55T-3 | 1 | Handle Socket Assembly |
| 4 | J55T-4 | 1 | Pump Plunger Pin |
| 5 | J55T-5 | 1 | Pump Plunger |
| 6 | J55T-6 | 1 | Pump Stop A |
| 7 | J55T-7 | 1 | Pump Stay Pin |
| 8 | J55T-8 | 1 | Pump Base |
| 9 | J55T-9 | 1 | Pump Stop B |
| 10 | J55T-10 | 1 | Safety Valve Ball |
| 11 | J55T-11 | 1 | Safety Valve Ball Guide |
| 12 | J55T-12 | 1 | Safety Valve Spring |
| 13 | J55T-13 | 1 | Safety Valve Adjusting Screw |
| 14 | J55T-14 | 1 | Safety Valve Plug |
| 15 | J55T-15 | 2 | Valve Plug |
| 16 | J55T-16 | 2 | Valve Spring |
| 17 | J55T-17 | 2 | Valve Ball |
| 18 | J55T-18 | 1 | Release Assembly |
| 19 | J55T-19 | 1 | Return Spring |
| 20 | J55T-20 | 1 | Ram Guide Ring |
| 21 | J55T-21 | 1 | Ram Packing Retainer |
| 22 | J55T-22 | 1 | Ram |
| 23 | J55T-23 | 1 | Hanger |
| 24 | J55T-24 | 1 | Snap Ring |
| 25 | J55T-25 | 1 | Stuffing Ring |
| 26 | J55T-26 | 1 | Stopper Ring |
| 27 | *J55T-27 | 1 | Filler Plug |
| 30 | J55T-30 | 1 | Push Nut |
| 31 | *J55T-31 | 1 | Pump Backup Ring |
| 32 | *J55T-32 | 1 | Pump Packing |
| 33 | *J55T-33 | 1 | Release Packing |
| 34 | J55T-34 | 1 | Ram Guide Ring Stopper |
| 35 | *J55T-35 | 1 | Ram Packing |
| 36 | *J55T-36 | 1 | Ram Backup Ring |
| 37 | *J55T-37 | 1 | Cylinder Packing |

PARTS INCLUDED BUT NOT SHOWN

| | | |
|--------|---|-------|
| 421687 | 1 | Decal |
|--------|---|-------|

Part numbers marked with an asterisk (*) are contained in Repair Kit No. J55T-28.

PARTS LIST FOR 10 TON JACK (J106T)

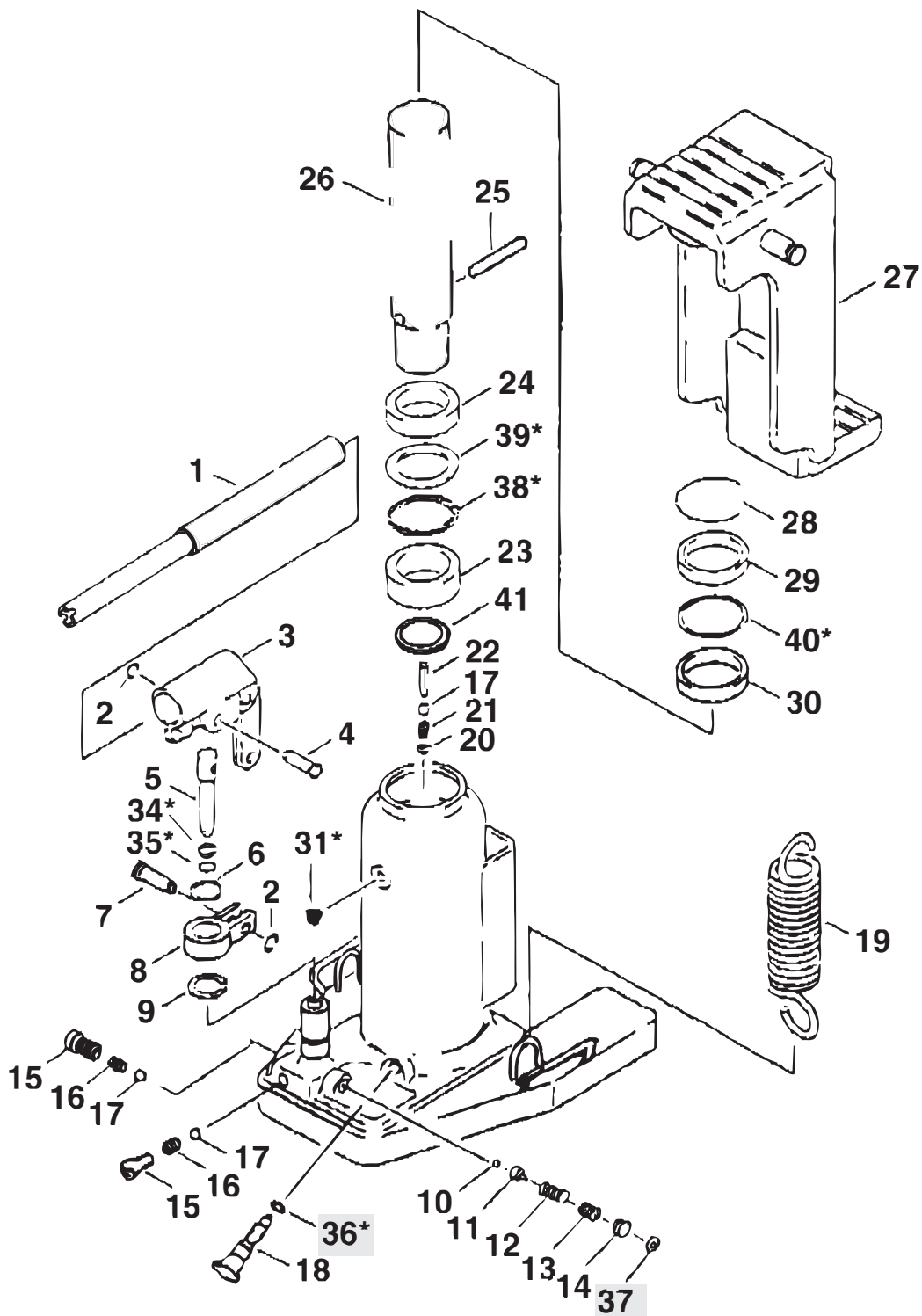

* = Parts marked with an asterisk (*) are in Repair Kit No. J106T-32.

Note: Shaded areas reflect last revision made to this form.

| Item No. | Part No. | No. Req'd | Description |
|----------|-----------|-----------|------------------------------|
| 1 | J106T-1 | 1 | Handle |
| 2 | J106T-2 | 1 | Snap Ring |
| 3 | J106T-3 | 1 | Handle Socket Assembly |
| 4 | J106T-4 | 1 | Pump Plunger Pin |
| 5 | J106T-5 | 1 | Pump Plunger |
| 6 | J106T-6 | 1 | Pump Stop A |
| 7 | J106T-7 | 1 | Pump Stay Pin |
| 8 | J106T-8 | 1 | Pump Base |
| 9 | J106T-9 | 1 | Pump Stop B |
| 10 | J106T-10 | 1 | Safety Valve Ball |
| 11 | J106T-11 | 1 | Safety Valve Ball Guide |
| 12 | J106T-12 | 1 | Safety Valve Spring |
| 13 | J106T-13 | 1 | Safety Valve Adjusting Screw |
| 14 | J106T-14 | 1 | Safety Valve Plug |
| 15 | J106T-15 | 1 | Valve Plug |
| 16 | J106T-16 | 1 | Valve Spring |
| 17 | J106T-17 | 1 | Valve Ball |
| 18 | J106T-18 | 1 | Release Assembly |
| 19 | J106T-19 | 1 | Return Spring |
| 20 | J106T-20 | 1 | Ram Spring Stopper Ring |
| 21 | J106T-21 | 1 | Ram Spring |
| 22 | J106T-22 | 1 | Vertical Pin |
| 23 | J106T-23 | 1 | Ram Guide Ring |
| 24 | J106T-24 | 1 | Ram Packing Retainer |
| 25 | J106T-25 | 1 | Horizontal Pin |
| 26 | J106T-26 | 1 | Ram |
| 27 | J106T-27 | 1 | Hanger |
| 28 | J106T-28 | 1 | Snap Ring |
| 29 | J106T-29 | 1 | Stuffing Ring |
| 30 | J106T-30 | 1 | Stopper Ring |
| 31 | *J106T-31 | 1 | Filler Plug |
| 34 | *J106T-34 | 1 | Pump Backup Ring |
| 35 | *J106T-35 | 1 | Pump Packing |
| 36 | *J106T-36 | 1 | Release Packing |
| 37 | J106T-37 | 1 | Push Nut |
| 38 | *J106T-38 | 1 | Ram Packing |
| 39 | *J106T-39 | 1 | Ram Backup Ring |
| 40 | *J106T-40 | 1 | Cylinder Packing |
| 41 | *J106T-41 | 1 | Ram Guide Ring Stopper |

PARTS INCLUDED BUT NOT SHOWN

| | | |
|--------|---|-------|
| 421688 | 1 | Decal |
|--------|---|-------|

Part numbers marked with an asterisk (*) are contained in Repair Kit No. J106T-32.