



HYDRAULIC JACK

Part No. 9006X Maximum Capacity: 6 Ton
Part No. 9011X Maximum Capacity: 11 Ton
Part No. 9013X Maximum Capacity: 13 Ton

INTRODUCTION

These instructions are written to help you, the user, more effectively use and maintain your Power Team jacks. Some of the information applying to construction, installation, operation, inspection, and maintenance of hydraulic jacks was selected from ANSI B30.1 and ASME PALD-1. The documents may be ordered from the American Society of Mechanical Engineers, United Engineering Center, 345 East 47th, New York, New York 10017.

SAFETY PRECAUTIONS



WARNING: To help prevent personal injury and damage to equipment,

- Read, understand, and follow all instructions, including the ANSI B30.1 and ASME PALD-1 safety codes.
- Always wear approved safety glasses.
- Inspect the jack before each use; do not use the jack if it is damaged, altered, or in poor condition.
- Use the jack for jacking purposes only.
- Never exceed the rated capacity of the jack.
- Only use the jack on a hard level surface.
- Center the load on the jack saddle. Off-center loads can damage the seals and cause jack failure.
- Lift only dead weight.
- Stay clear of lifted loads. Use safety stands to support the load before making repairs.
- Use only Power Team hydraulic fluid.

This guide cannot cover every situation, so always do the job with safety first.

OPERATING INSTRUCTIONS

1. To raise the jack, close the release valve tightly by turning it clockwise. Insert the handle into the handle socket and operate the pump.
2. To lower the jack, slowly open the release valve stem by turning it counterclockwise.
3. For horizontal operation, position jack on its side so that the release valve is down for full piston extension.

PREVENTIVE MAINTENANCE

IMPORTANT: The greatest single cause of failure in hydraulic units is dirt. Keep the jack clean and well lubricated to prevent foreign matter from entering the system. If the jack has been exposed to rain, snow, sand, or grit, it must be cleaned before it is used.

1. When the jack is not in use, keep the piston and pump rods fully retracted. Store the jack on its base and in a well protected area where it will not be exposed to corrosive vapors, abrasive dust, or any other harmful elements.
2. Visually inspect the jack before each use. Take corrective action if any of the following problems are found:
 - a. Cracked or damaged housing
 - b. Excessive wear, bending, or other damage
 - c. Leaking hydraulic fluid
 - d. Scored or damaged piston rod
 - e. Incorrectly functioning swivel heads or adjusting screws
 - f. Loose hardware
 - g. Modified or altered equipment

TROUBLE-SHOOTING GUIDE

Repair procedures must be performed in a dirt-free environment by qualified personnel who are familiar with this equipment.

| TROUBLE | CAUSE | SOLUTION |
|---|---|--|
| Erratic Action | <ol style="list-style-type: none"> 1. Air in system 2. Viscosity of oil too high 3. Internal leakage in cylinder 4. Cylinder sticking or binding | <ol style="list-style-type: none"> 1. With jack sitting on its base and ram retracted, bleed air by opening release valve. Pump for 10 seconds. 2. Change to lower viscosity oil. 3. Replace worn seals. Check for excessive contamination or wear. 4. Check for dirt, gummy deposits, or leaks. Check for misalignment, worn parts, or defective seals. |
| Jack does not advance | <ol style="list-style-type: none"> 1. Release valve is open 2. Low/no oil in reservoir 3. Air-locked system 4. Load is above capacity of system | <ol style="list-style-type: none"> 1. Close release valve 2. Fill with oil and bleed system 3. Bleed the system 4. Use correct equipment |
| Jack only extends partially | <ol style="list-style-type: none"> 1. Reservoir is low on oil 2. Piston rod is binding | <ol style="list-style-type: none"> 1. Fill reservoir 2. Check for dirt, gummy deposits, or leaks. Check for misalignment, worn parts, or defective seals. |
| Jack advances slowly | <ol style="list-style-type: none"> 1. Pump not working correctly 2. Leaking seals | <ol style="list-style-type: none"> 1. Rework pump 2. Replace seals |
| Jack advances but doesn't hold pressure | <ol style="list-style-type: none"> 1. Cylinder seals are leaking 2. Pump check valve not working correctly 3. Overload valve leaking or not adjusted correctly | <ol style="list-style-type: none"> 1. Replace seals 2. Clean/replace check valve 3. Replace/adjust overload valve |
| Jack leaks oil | <ol style="list-style-type: none"> 1. Worn or damaged seals | <ol style="list-style-type: none"> 1. Replace seals |
| Jack will not retract or retracts slowly | <ol style="list-style-type: none"> 1. Release valve is closed 2. Cylinder damaged internally 3. Reservoir too full | <ol style="list-style-type: none"> 1. Open release valve 2. Send jack to authorized service center for repair 3. Drain oil to correct level |

PARTS LIST FOR 9006X

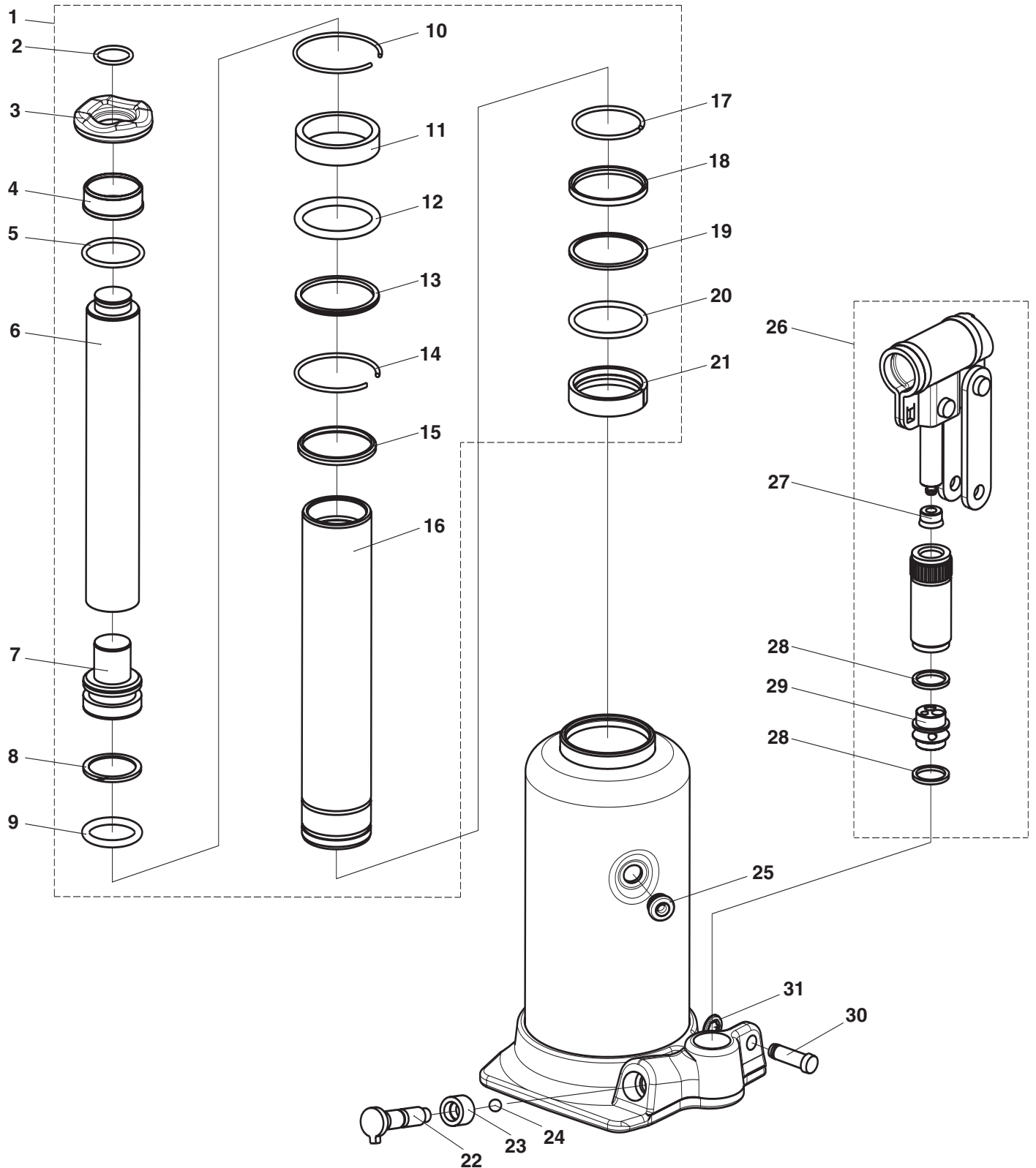

PARTS LIST FOR 9006X

| Item No. | Part No. | No. Req'd | Description |
|----------|-------------------|-----------|---------------------------------|
| 1 | 9006X-16 | 1 | Kit, Telescoping Ram Complete |
| 2 | * | 1 | Spring Ring |
| 3 | * | 1 | Support Cap |
| 4 | •* | 1 | Guide Ring |
| 5 | * | 1 | Spring Ring |
| 6 | * | 1 | Ram |
| 7 | * | 1 | Ram Plug |
| 8 | •* | 1 | Backing Ring |
| 9 | •* | 1 | O-Ring |
| 10 | * | 1 | Spring Ring |
| 11 | •* | 1 | Support Ring |
| 12 | * | 1 | O-Ring |
| 13 | •* | 1 | Ring |
| 14 | * | 1 | Spring Ring |
| 15 | * | 1 | Ring |
| 16 | * | 1 | Outer Ram |
| 17 | * | 1 | Spring Ring |
| 18 | * | 1 | Ring |
| 19 | •* | 1 | Backing Ring |
| 20 | * | 1 | O-Ring |
| 21 | •* | 1 | Guide Ring |
| 22 | 9006X-19 | 1 | Release Rod |
| 23 | • 9006X-20 | 1 | Release Rod Seal |
| 24 | 9006X-14 | 1 | Ball |
| 25 | • 9006X-3 | 1 | Plug, Filler |
| 26 | xxxxxxx | 1 | Kit, Pump Unit & Handle Bracket |
| 27 | † | 1 | Plunger Seal |
| 28 | •† | 2 | Seal |
| 29 | † | 1 | Valve Block |
| 30 | 9006X-6 | 1 | Link Pin |
| 31 | • 9006X-7 | 1 | Locking Washer |

PARTS INCLUDED BUT NOT SHOWN

| | | |
|----------------|---|--------------------------|
| 9006X-2 | 1 | Jack Handle, Replacement |
| 421680 | 1 | Decal |

Parts marked with an asterisk (*) on this list are contained in Telescoping Ram Kit (Item 1.)

Parts marked with a dagger (†) are contained in Pump Piston and Handle Bracket Kit No. 9006X-17.

Parts marked with a bullet (•) are contained in Repair Kit No. xxxxxx.

PARTS LIST FOR 9011X

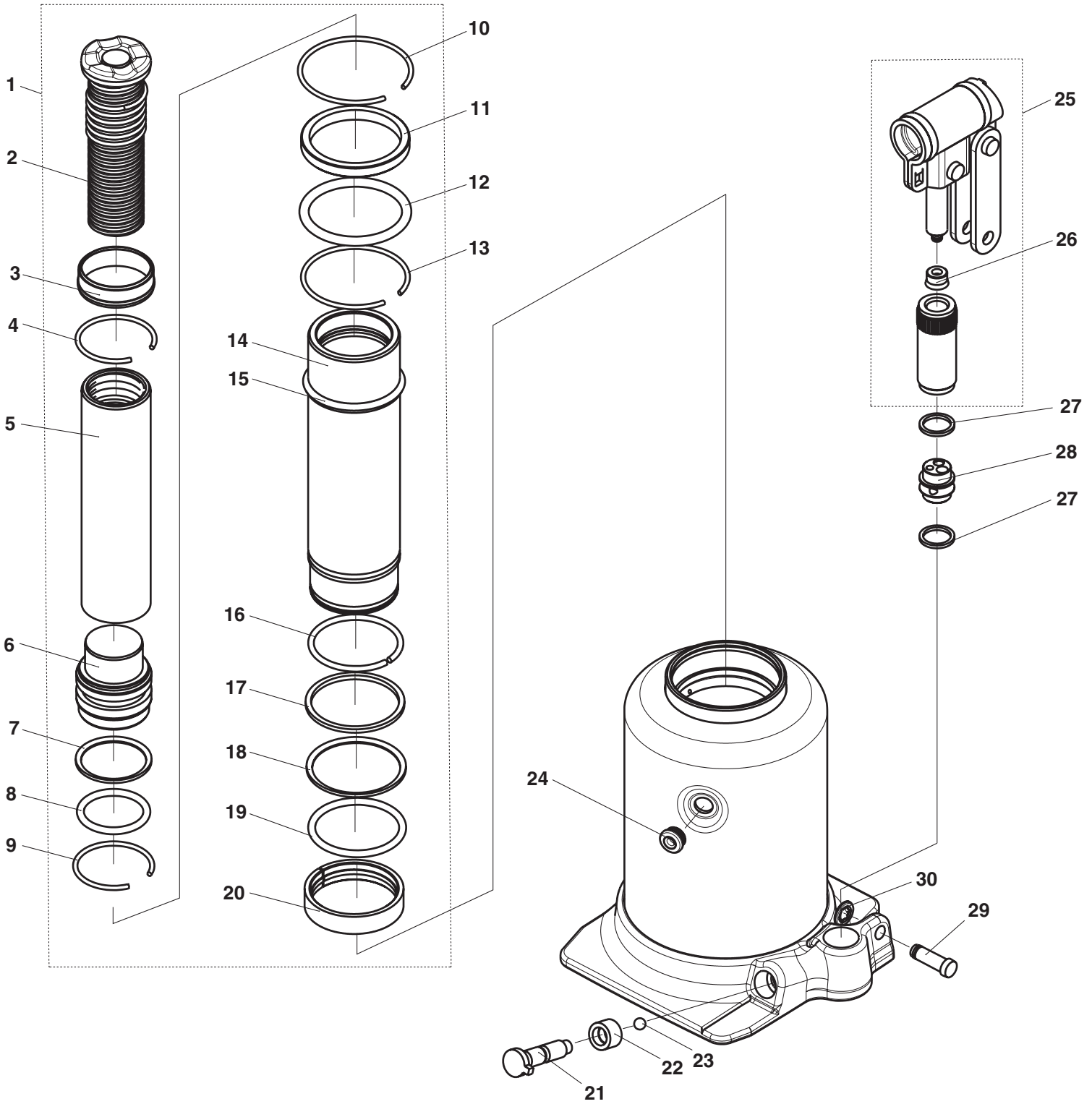

PARTS LIST FOR 9011X

| Item No. | Part No. | No. Req'd | Description |
|----------|-------------------|-----------|---------------------------------|
| 1 | 9011X-14 | 1 | Kit, Telescoping Ram Complete |
| 2 | * | 1 | Extension Screw |
| 3 | •* | 1 | Guide Ring |
| 4 | * | 1 | Spring Ring |
| 5 | * | 1 | Inner Ram |
| 6 | * | 1 | Ram Plug |
| 7 | •* | 1 | Backing Ring |
| 8 | •* | 1 | O-Ring |
| 9 | * | 1 | Spring Ring |
| 10 | •* | 1 | Spring Ring |
| 11 | * | 1 | Support Ring |
| 12 | •* | 1 | O-Ring |
| 13 | * | 1 | Spring Ring |
| 14 | * | 1 | Outer Ram |
| 15 | * | 1 | Stop Ring |
| 16 | * | 1 | Spring Ring |
| 17 | * | 1 | Support Ring |
| 18 | •* | 1 | Backing Ring |
| 19 | * | 1 | O-Ring |
| 20 | •* | 1 | Guide Ring |
| 21 | 9006X-19 | 1 | Release Rod |
| 22 | • 9006X-20 | 1 | Release Rod Seal |
| 23 | 9006X-14 | 1 | Ball |
| 24 | • 9006X-3 | 1 | Plug, Filler |
| 25 | xxxxxxx | 1 | Kit, Pump Unit & Handle Bracket |
| 26 | † | 1 | Plunger Seal |
| 27 | •† | 2 | Seal |
| 28 | † | 1 | Valve Block |
| 29 | 9033B-14 | 1 | Link Pin |
| 30 | • 9033B-15 | 1 | Locking Washer |

PARTS INCLUDED BUT NOT SHOWN

| | | |
|----------------|---|--------------------------|
| 9006X-2 | 1 | Jack Handle, Replacement |
| 421680 | 1 | Decal |

Parts marked with an asterisk (*) on this list are contained in Telescoping Ram Kit (Item 1.)

Parts marked with a dagger (†) are contained in Pump Piston and Handle Bracket Kit No. xxxxxxx.

Parts marked with a bullet (•) are contained in Repair Kit No. xxxxxxx.

PARTS LIST FOR 9013X

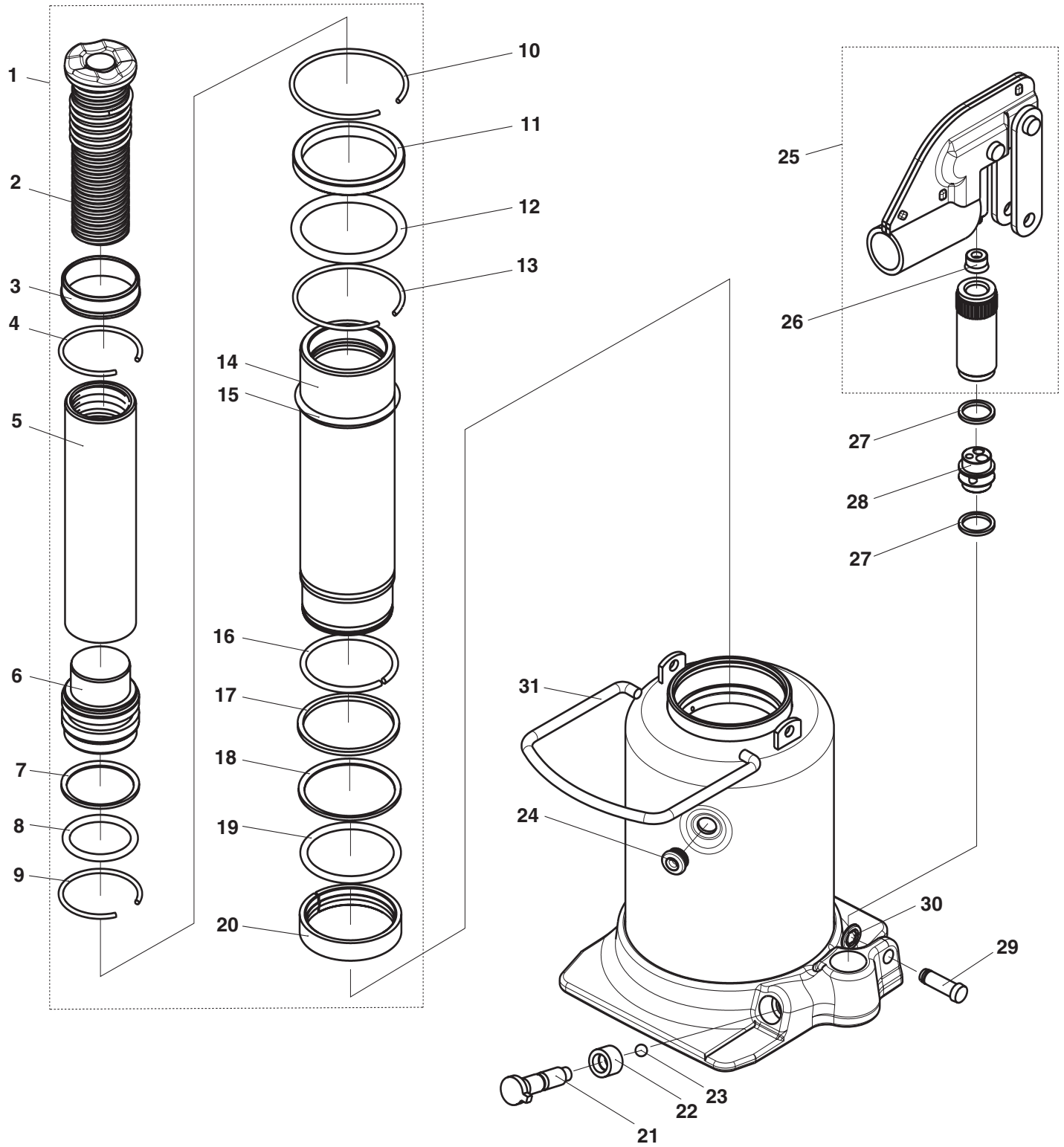

PARTS LIST FOR 9013X

| Item No. | Part No. | No. Req'd | Description |
|----------|-------------------|-----------|---------------------------------|
| 1 | 9013X-13 | 1 | Kit, Telescoping Ram Complete |
| 2 | * | 1 | Extension Screw |
| 3 | •* | 1 | Guide Ring |
| 4 | * | 1 | Spring Ring |
| 5 | * | 1 | Inner Ram |
| 6 | * | 1 | Ram Plug |
| 7 | •* | 1 | Backing Ring |
| 8 | •* | 1 | O-Ring |
| 9 | * | 1 | Spring Ring |
| 10 | •* | 1 | Spring Ring |
| 11 | * | 1 | Support Ring |
| 12 | •* | 1 | O-Ring |
| 13 | * | 1 | Spring Ring |
| 14 | * | 1 | Outer Ram |
| 15 | * | 1 | Stop Ring |
| 16 | * | 1 | Spring Ring |
| 17 | * | 1 | Support Ring |
| 18 | •* | 1 | Backing Ring |
| 19 | * | 1 | O-Ring |
| 20 | •* | 1 | Guide Ring |
| 21 | 9006X-19 | 1 | Release Rod |
| 22 | • 9006X-20 | 1 | Release Rod Seal |
| 23 | 9006X-14 | 1 | Ball |
| 24 | • 9006X-3 | 1 | Plug, Filler |
| 25 | xxxxxxxx | 1 | Kit, Pump Unit & Handle Bracket |
| 26 | † | 1 | Plunger Seal |
| 27 | •† | 2 | Seal |
| 28 | † | 1 | Valve Block |
| 29 | 9033B-14 | 1 | Link Pin |
| 30 | • 9033B-15 | 1 | Locking Washer |
| 31 | | 1 | Carrying Handle |

PARTS INCLUDED BUT NOT SHOWN

| | | |
|----------------|---|--------------------------|
| 9006X-2 | 1 | Jack Handle, Replacement |
| 421680 | 1 | Decal |

Parts marked with an asterisk (*) on this list are contained in Telescoping Ram Kit (Item 1.)

Parts marked with a dagger (†) are contained in Pump Piston and Handle Bracket Kit No. xxxxxxxx.

Parts marked with a bullet (•) are contained in Repair Kit No. xxxxxxxx.

POWER TEAM®



UNITED STATES

*SPX Corporation-Fluid Power
5885 11th Street
Rockford, IL 61109-3699
USA
Telephone: 1-815-874-5556
FAX: 1-815-874-7853*

Cust. Service/Order Entry

*Tel: 1-800-541-1418
FAX: 1-800-288-7031*

E-mail:
info@fluidpower.spx.com

Technical Services

*Tel: 1-800-477-8326
FAX: 1-800-765-8326*



CHINA

*212 Jiang Ning Road
CATIC Tower 23C
Shanghai 200041, China
Tel: 86 (21) 5289 5858
FAX: 86 (21) 5289 5866
E-mail:
info.asia@fluidpower.spx.com*



FAR EAST

*7 Gul Circle
Singapore 629563
Singapore
Tel: (65) 6265-3343
FAX: (65) 6265-6646
E-mail:
info.asia@fluidpower.spx.com*



EUROPE

*Albert Thijsstraat 12
6471 WX Eyselshoven
Netherlands
Tel: 31 (45) 5678877
FAX: 31 (45) 5678878
E-mail
info.europe@fluidpower.spx.com*

For more information, Internet address: <http://www.powerteam.com> (or) <http://www.hytec.com>